

## Data sheet - FTI07M5 SS43

### FASTEKS® thread inserts with cutting holes

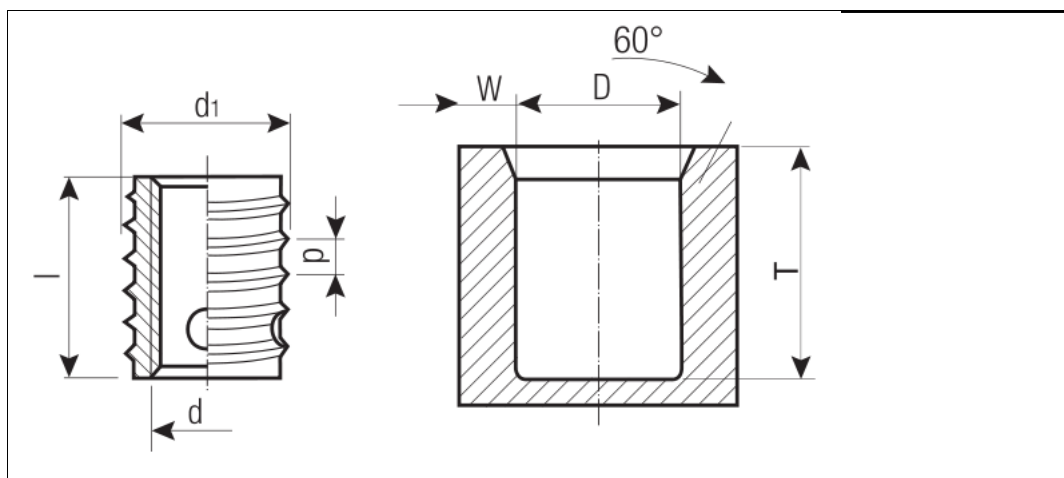

Type	FASTEKS® thread inserts with cutting holes
Order description	FTI07M5 SS43
Material	Stainless steel 1.4305
	Thread insert*
d	M5
l	7 mm
d1	8 mm
p	1.00 mm
	Location hole**
Tmin	9 mm
D Metal	7.6 - 7.7 mm
D Plastic	7.4 - 7.6 mm
Wmin Light alloys	1.60 mm
Wmin Cast iron	2.40 mm
Wmin Plastic	2.00 mm
Additional types	on request
Tolerances	Internal and external threads conform to Tolerance ISO 2 (6H), further dimensions ISO 2768-m.
Installation data	Please note that the mm dimensions quoted represent standard values and may vary depending on the material of the molded part. It is advisable to run trials prior to series production.

uniform resource locator: