



**HOWMET
AEROSPACE**



Camloc 
Traditionally Innovative[®]

Quick Release Fasteners



Latches



Specials

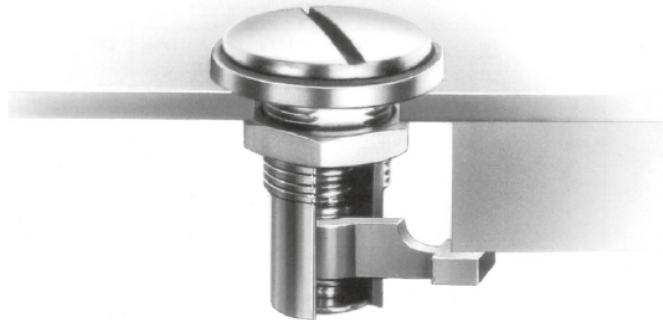

Inserts





Page

General Information A-2

Important Information A-3 - A-4

General Installation Instructions for 1/4-Turn Fasteners A-5

Overview Quick-Operating Fasteners A-6

1/4-Turn Fasteners

5F Series B-1 - B-4

99F Series C-1 - C-3

50F Series (650 N Working Load) D-1 - D-7

50F Series (2.600 N Working Load) E-1 - E-6

2600 / 2700 Series F-1 - F-12

D4002Series G-1 - G-13

991F Series H-1 - H-6

One-Piece Fasteners

V936F Series I-1 - I-2

713F Series J-1 - J-2

Push Button Fasteners

15F Series K-1 - K-4

Push-Turn Fasteners

715F Series L-1 - L-3

716F Series M-1 - M-3

717F Series N-1 - N-3

PT10 Series O-1 - O-4

Index



The Camloc brand was established in 1937. Since that time our fastening systems have been successfully integrated into numerous applications within many different industries.

Our customers benefit from our more than 80 years of fastening experience.

We provide local support for innovative, high quality fastening systems supplied globally to the strictest environmental and working conditions.

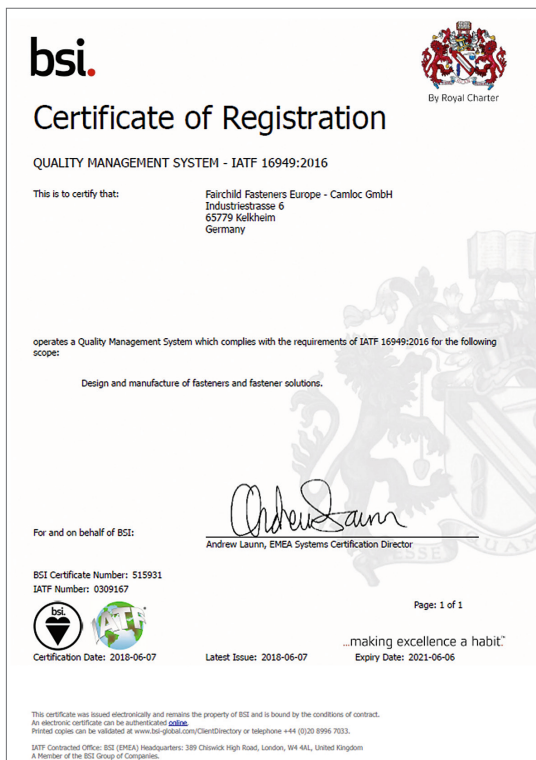

IATF 16949:2016



ISO 14001:2015

Your Howmet Fastening Systems team

Disclaimer:

Parts listed are subject to technical changes. All dimensions in mm. All information is correct to the best of our knowledge at the time of printing. No liability for disadvantages caused by printing errors or false application.

Advantages of the Camloc 1/4-Turn Fastener

- Secure quick release fastener system
- Locking and unlocking by a quarter turn
- Long life - high number of operating cycles
- Hand or tool-operated
- Easy to use and fast operation reduces assembly costs
- Camloc fasteners are standardised worldwide
- Wide range of sizes
- Stud assemblies are captive in the panel
- Tolerance compensating
- Vibration-resistant

Components

The 1/4-turn fastener consists of a stud, retaining ring and receptacle.

¼ turn fasteners require a spring element in the joint to enable them to work correctly. Depending upon the fastener type and mounting requirements the spring element can be part of the stud assembly or incorporated in the receptacle.

Stud assemblies with snap-in grommets are available on some series giving a captive assembly without the need for a retaining washer.

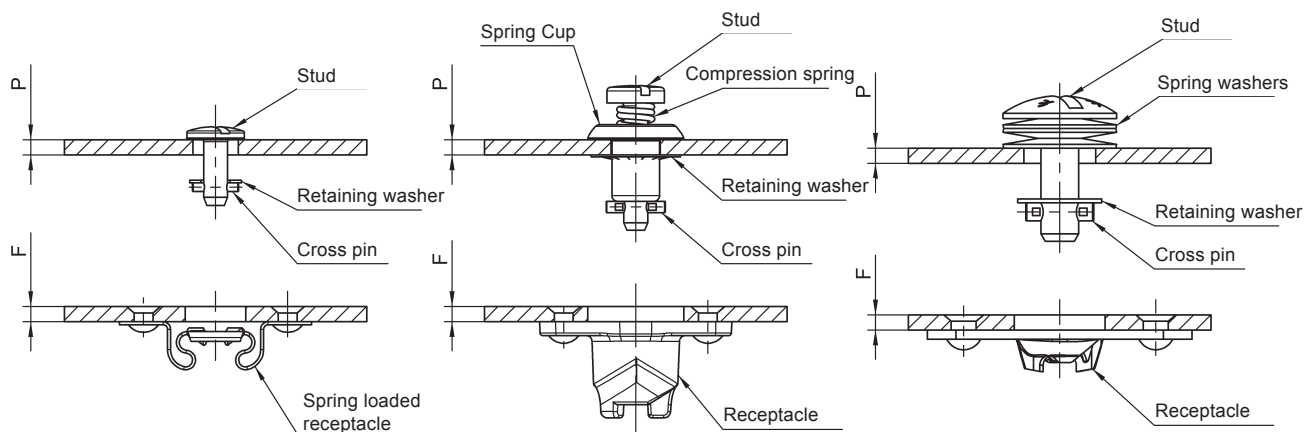

Design Principles

Quarter-turn fasteners connect components under an elastic preload.

The spring element to produce the preload can be part of the stud or receptacle.

Fastener tensile loads specified in the catalogue are reached after overcoming the spring element generated preload.

Unlike threaded fasteners, Camloc fasteners do not rely on the elasticity of joint and fastener materials to accomplish preload. The stud assembly or receptacle is designed with a spring element which allows repeated application of controlled preload with assured reliability over an high number of cycles.

Click here: [Camloc Quarter Turn Fastener](#) (Youtubelink)



How it Operates

When the stud assembly is rotated, the stud cross pin rides up the cam causing a controlled joint preload to be applied. This action is accomplished by rotating the stud 90°. At this point a positive mechanical stop is reached and the cross pin falls into the locking detent. Excellent resistance to vibration induced loosening is assured.

Stud Assembly

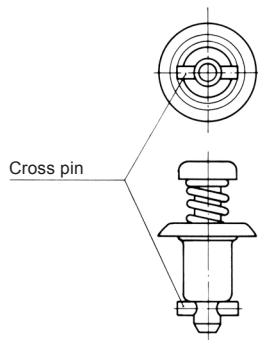

Receptacle

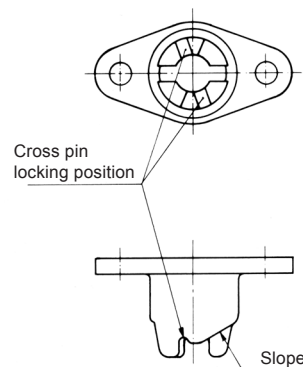

Unlocked

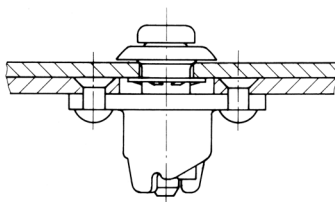

Locked

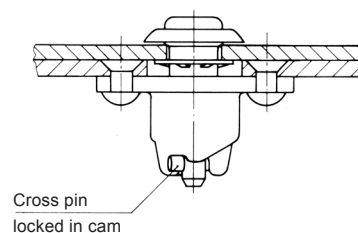

Lock and unlock the stud by a quarter turn.

For general installation instructions please refer to the next page.

Selecting the Fastener

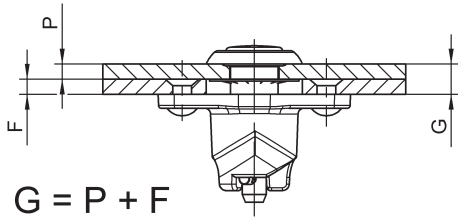

P = panel thickness (stud assembly)

F = frame thickness (receptacle)

G = total thickness, consisting of P + F as well as possible gaskets, paint thickness or gaps.
This dimension gives the stud length number in the corresponding series tables.

Installation

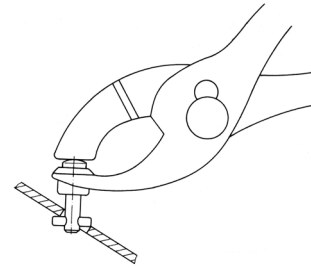
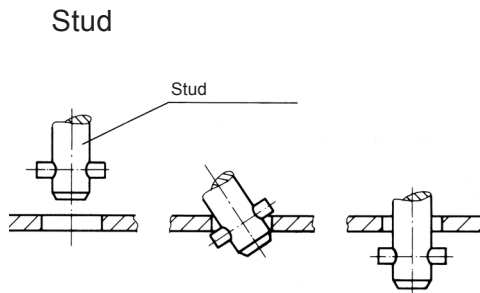

For short, spring-loaded stud assemblies, the use of 4P3-1 pliers is recommended.

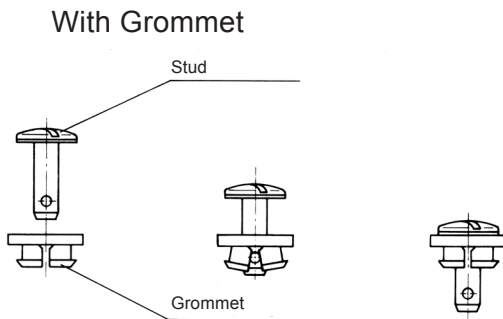

With retaining washer (slotted)

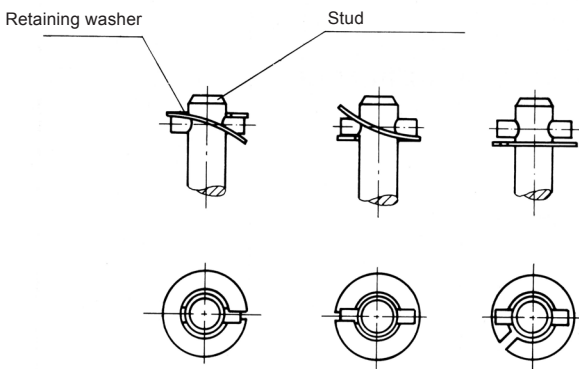

With retaining washer

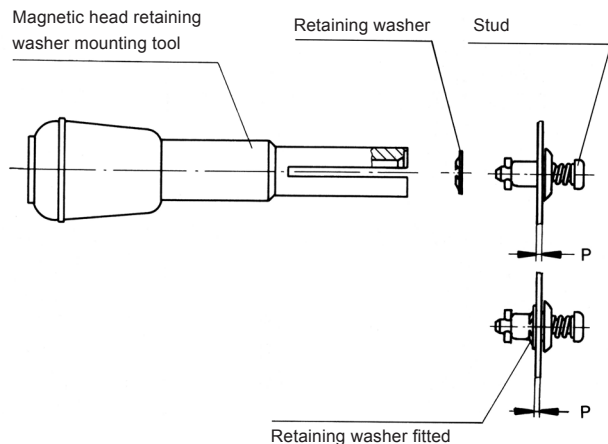

Overview Quick-Operating Fasteners

Series	Max. Tensile Strength*	Working Load*	Slotted Recess Head	Cross Recess Head	Hex Head	Hex Recess Head	Fixed Wing Handle	Offset Fixed Wing Handle	Folding Bail Handle	Pages
5F	670 N	450 N	X	X						B1-B4
99F	700 N	480 N	X							C1-C3
50F	900 N	650 N	X	X	X	X	X	X	X	D1-D6
50F	3.700 N	2.600 N	X	X	X	X	X	X	X	E1-E6
2600	1.330 N	900 N	X	X			X		X	F1-F12
2700	1.330 N	900 N	X	X						F1-F12
D4002	4.700 N	3.100 N	X	X		X	X		X	G1-G13
991F	10.000 N	7.000 N			X	X	X	X	X	H1-H5
V936F	300 N	200 N	X							I1-I2
715F	700 N	600 N	X							L1-L3
716F	1.400 N	1.200 N	X							M1-M3
PT10	1.200 N	800 N	X	X						O1-O4
717F	3.000 N	2.500 N	X							N1-N3

Series	Max. Tensile Strength*	Working Load*	Plastic Star Form Handle	Fixed Wing Handle Plastic	Square Head	Knurled Head	Triangular Plastic Handle	Folding Wing Handle	Push Button	Pages
50F	900 N	650 N	X	X						D1-D6
50F	3.700 N	2.600 N	X	X	X					E1-E6
2600	1.330 N	900 N	X	X		X	X			F1-F12
D4002	4.700 N	3.100 N	X							G1-G13
991F	10.000 N	7.000 N	X					X		H1-H5
15F	1.330 N	930 N							X	K1-K4
V936F	300 N	200 N				X				I1-I2
715F	700 N	600 N				X				L1-L3
716F	1.400 N	1.200 N				X				M1-M3
PT10	1.200 N	800 N		X						O1-O4
717F	3.000 N	2.500 N				X				N1-N3

* Load limitations within series are possible. Please check the footnotes on the relevant catalogue pages.



Features

Max. tensile strength 670 N, working load 450 N.
Plastic washer stud assembly to protect decorative surfaces.
Spring loaded receptacle.

Selection Instructions

1. Select stud assembly and receptacle, page B-2 und B-4.
2. Select retaining washer or grommet, page B-3.
3. Select stud length number from total thickness G using the formula and table below (e.g. V5S5-*AGV).

Determining the stud length number:

With retaining washer
 $G = P + F$



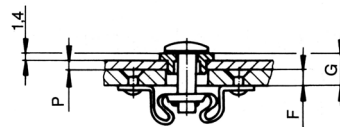

With Grommet
 $G = P + F + 1,4$
 $G_{\min} = 3,9 \text{ mm}$



Stud Length Table

Total Thickness G	Stud Length No. When Using Receptacles
0,50 - 0,90	1
0,90 - 1,30	2
1,30 - 1,65	3
1,65 - 2,05	4
2,05 - 2,40	5
2,40 - 2,80	6
2,80 - 3,20	7
3,20 - 3,55	8
3,55 - 3,95	9
3,95 - 4,30	10
4,30 - 4,70	11
4,70 - 5,10	12
5,10 - 5,45	13
5,45 - 5,85	14
5,85 - 6,20	15
6,20 - 6,60	16
6,60 - 7,00	17
7,00 - 7,35	18
7,35 - 7,75	19
7,75 - 8,15	20
8,15 - 8,50	21

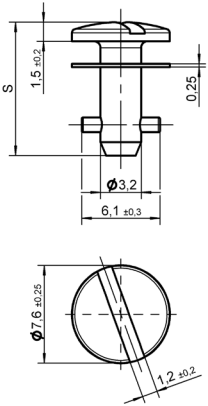
Other lengths on request.

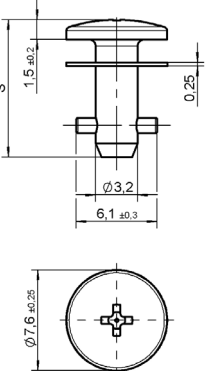
Style	Dimensions	Materials / Finish	°C	Part No.
Slotted Recess Head 	 S = 6,70 + (0,38 x length no.)	Steel / zinc-plated, CrVI-free, clear passivation with plastic washer (PA6)	100	V5S5- *AGV
		Steel / nickel-plated with plastic washer (PA6)	100	5S27-*
Cross Recess Head 	 S = 6,70 + (0,38 x length no.)	Steel / zinc-plated, CrVI-free, clear passivation with plastic washer (PA6)	100	V5S21- *AGV
		Stainless steel with stainless steel washer (tensile strength 470 N max. working load 300 N)	200	5S15-*

* Length no. from Table, page B-1.
 For installation dimensions see page B-3.

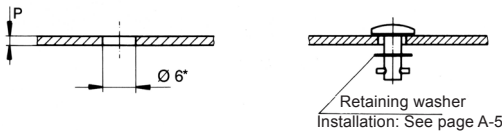
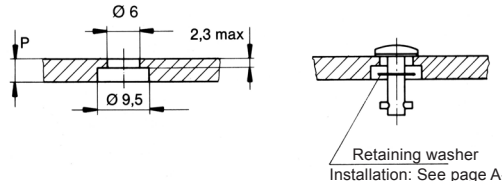
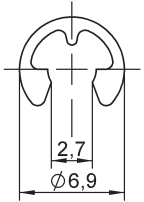
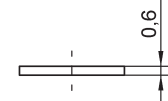
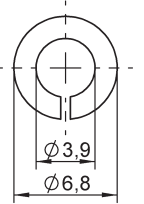
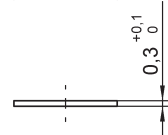
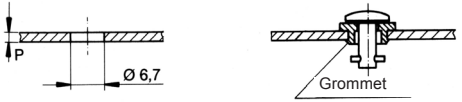
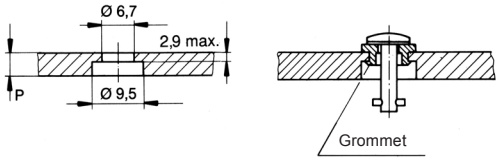
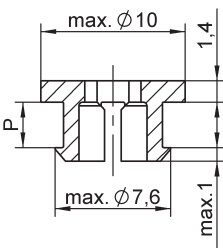
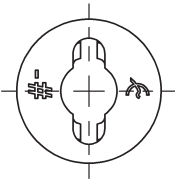
Installation Dimensions	Accessories	Material / Finish	Panel Thickness P	Part No.						
<p>Retaining Washer Panel Thickness P up to 2,3</p>  <p>Retaining washer Installation: See page A-5</p> <p>Panel thickness P over 2,3</p>  <p>Retaining washer Installation: See page A-5</p> <p>* For P up to 1,4 : Ø 5,6 for installation without retaining washer</p>	<p>Retaining washer</p>   <p>Retaining washer</p>  	<p>Steel/zinc-plated, CrVI-free, clear passivation</p> <p>Stainless steel</p>	<p></p>	<p>V5W3-1AG</p> <p>5S3-2</p>						
<p>Snap-In Grommet Panel thickness P up to 2,9</p>  <table border="1" data-bbox="215 1668 391 1747"> <thead> <tr> <th>P max</th> <th>G min</th> </tr> </thead> <tbody> <tr> <td>1,4</td> <td>2,0</td> </tr> <tr> <td>2,9</td> <td>3,5</td> </tr> </tbody> </table> <p>Panel thickness P over 2,9</p>  <p>Grommet</p>	P max	G min	1,4	2,0	2,9	3,5	<p>Grommet</p>  	<p>Plastic (PA6) black</p>	<p>to 1,4</p> <p>1,8 - 2,9</p>	<p>5S72-5-1AA</p> <p>5S72-9-1AA</p>
P max	G min									
1,4	2,0									
2,9	3,5									

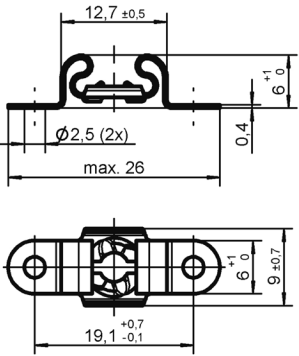
Style	Dimensions	Materials / Finish	°C	Part-No.
Type 1 Rivet / Screw Mounting 		Steel / zinc flake coated	180	V5R2-1AK7
		Stainless steel	200	5R2-3

Receptacle Installation Instructions

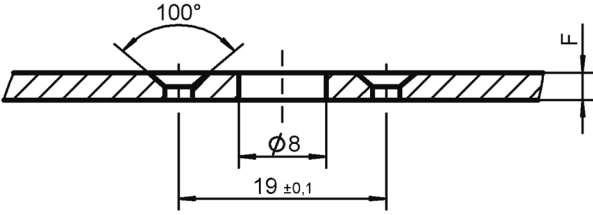
Dimensions
<p style="text-align: center;">Rivet / Screw Mounting</p> 

Features

Max. tensile strength 700 N, working load 480 N.

Increased grip range.

Externally threaded receptacles for use in castings or on panels with a retaining nut (see page C-3).

Encapsulated design, splash-proof.

Selection Instructions

1. Select stud assembly and receptacle, page C-2 and C-3.
2. Select hex nut for receptacle, if necessary, page C-3.
3. Select stud retaining washer, page C-2.
4. Select stud length number from total thickness G using the formula and table below (e.g. 99S10-01AG).

Determining the stud length number:

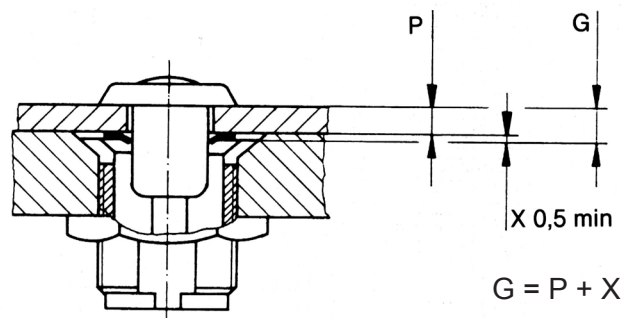

Total Thickness G	Stud Length No.
0,5 - 1,5	01
1,5 - 3,0	03
3,0 - 4,5	05
4,5 - 6,0	07
6,0 - 7,5	09
7,5 - 9,0	11
9,0 - 10,5	13
10,5 - 12,0	15
12,0 - 13,5	17
13,5 - 15,0	19

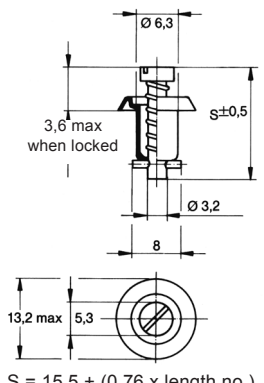

Other lengths on request.

Style	Dimensions	Materials / Finish	°C	Part No.
Slotted Recess Head 	 <p>S = 15,5 + (0,76 x length no.)</p>	Steel / zinc-plated, CrVI-free, clear passivation	100	V99S10-*AG

* Length no. from Table, see page C-1.

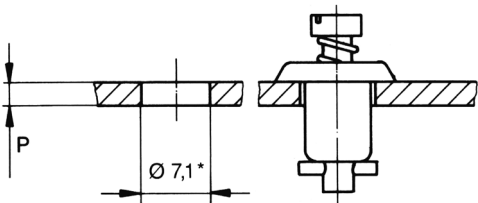
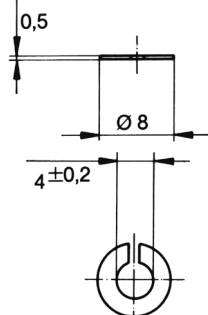
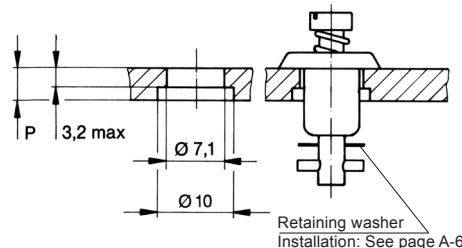
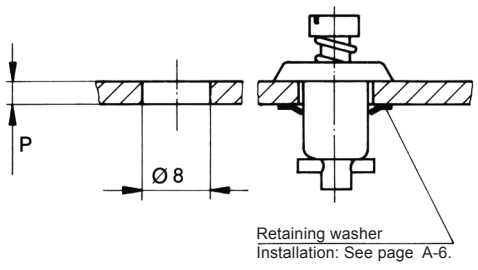
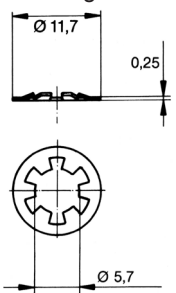
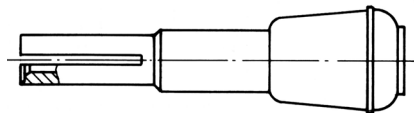
Stud Installation Instructions

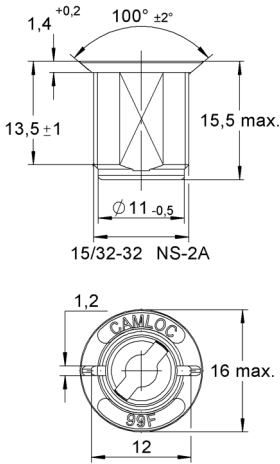
Installation Dimensions	Accessories	Materials / Finish	Part No.
Panel Thickness P 0,5 - 3,2  <p>* For P up to 1,65 m Ø 6,5 for installation without retaining washer</p>	Retaining washer 	Stainless steel	2600-SW
Panel Thickness P over 3,2  <p>Retaining washer Installation: See page A-6.</p>			
Panel Thickness P 0,50 - 4,75  <p>Retaining washer Installation: See page A-6.</p>	Retaining washer 	Steel / zinc-plated, CrVI-free, transparent passivated Stainless steel	99W10-01A1 V2600-LW-7
	Mounting tool for retaining washer V2600-LW-7 and 99W10-01A1		T98-1

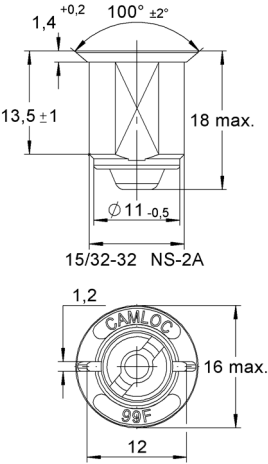
Style	Dimensions	Materials / Finish	°C	Part No.
<p>Open</p> 		Zinc die casting / zinc-plated, CrVI-free, clear passivation	100	99R10-01A1
<p>Encapsulated</p> 		Zinc die casting / zinc-plated, CrVI-free, clear passivation Capsule: Stainless steel	100	99E10-01

Receptacle Installation Instructions

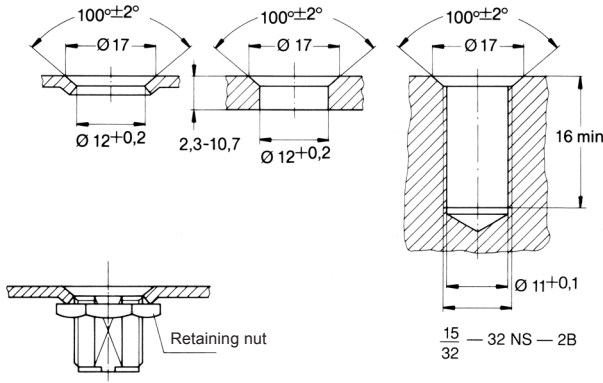
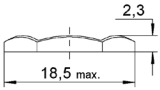
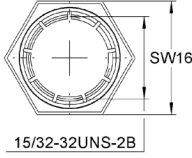
Installation Dimensions	Accessories	Materials / Finish	Part No.
 <p>Installation torque 3 Nm</p>	<p>Retaining nut</p>  <p>Tap</p> 	Steel / zinc-plated, CrVI-free, clear passivation	99N10-01A1 15/32-32 NS-2B



Features

- Max. tensile strength 900 N, working load 650 N.
- Stud assembly incorporates a plastic washer to protect decorative surfaces.
- Snap-in or clip-on spring loaded receptacle.
- Snap-in grommet for quick stud installation without a retaining washer.

Selection Instructions



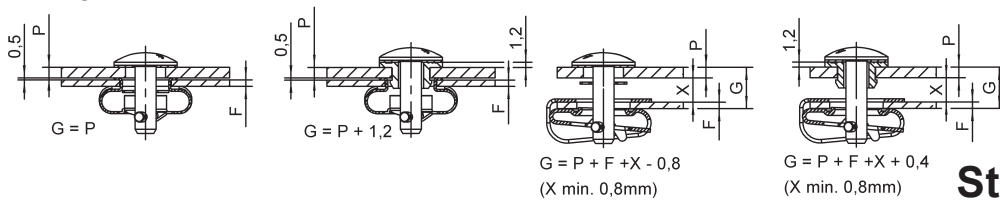

- Select stud assembly and receptacle, page D-2 to D-4 and D-6.
- Select retaining washer or grommet, page D-5.
- Select stud length number from total thickness G using the formula and table below (e.g. 50E21-*AGV).





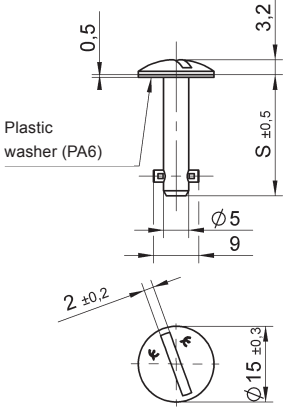

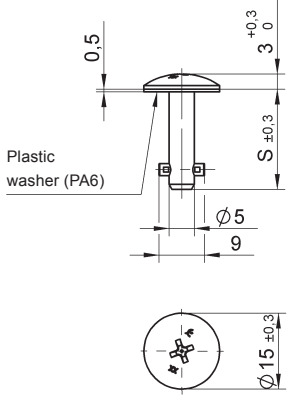
Stud Length Table

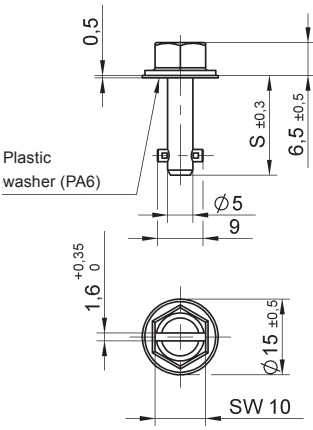
Total Thickness G	Stud Length No. when using Receptacles Type 1 F= 1,0 - 2,1	Total Thickness G	Stud Length No. when using Receptacles Type 2 F= 2,1 - 3,0	Total Thickness G	Stud Length No. when using Receptacles Type 3
0,50 - 1,10	5	0,50 - 1,10	7	2,30 - 2,90	5
1,10 - 1,70	6	1,10 - 1,70	8	2,90 - 3,50	6
1,70 - 2,30	7	1,70 - 2,30	9	3,50 - 4,10	7
2,30 - 2,90	8	2,30 - 2,90	10	4,10 - 4,70	8
2,90 - 3,50	9	2,90 - 3,50	11	4,70 - 5,30	9
3,50 - 4,10	10	3,50 - 4,10	12	5,30 - 5,90	10
4,10 - 4,70	11	4,10 - 4,70	13	5,90 - 6,50	11
4,70 - 5,30	12	4,70 - 5,30	14	6,50 - 7,10	12
5,30 - 5,90	13	5,30 - 5,90	15	7,10 - 7,70	13
5,90 - 6,50	14	5,90 - 6,50	16	7,70 - 8,30	14
6,50 - 7,10	15	6,50 - 7,10	17	8,30 - 8,90	15
7,10 - 7,70	16	7,10 - 7,70	18	8,90 - 9,50	16
7,70 - 8,30	17	7,70 - 8,30	19	9,50 - 10,10	17
8,30 - 8,90	18	8,30 - 8,90	20	10,10 - 10,70	18
8,90 - 9,50	19	8,90 - 9,50	21	10,70 - 11,30	19
9,50 - 10,10	20	9,50 - 10,10	22	11,30 - 11,90	20
10,10 - 10,70	21	10,10 - 10,70	23	11,90 - 12,50	21
10,70 - 11,30	22	10,70 - 11,30	24	12,50 - 13,10	22
11,30 - 11,90	23	11,30 - 11,90	25	13,10 - 13,70	23
11,90 - 12,50	24	11,90 - 12,50	26	13,70 - 14,30	24
12,50 - 13,10	25	12,50 - 13,10	27	14,30 - 14,90	25
13,10 - 13,70	26	13,10 - 13,70	28	14,90 - 15,50	26
13,70 - 14,30	27	13,70 - 14,30	29	15,50 - 16,10	27
14,30 - 14,90	28	14,30 - 14,90	30	16,10 - 16,70	28
14,90 - 15,50	29	14,90 - 15,50	31	16,70 - 17,30	29
15,50 - 16,10	30	15,50 - 16,10	32	17,30 - 17,90	30



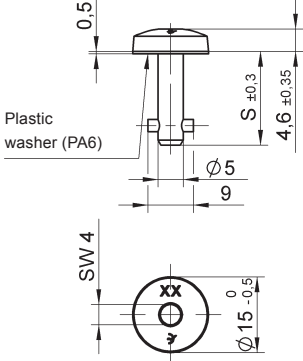

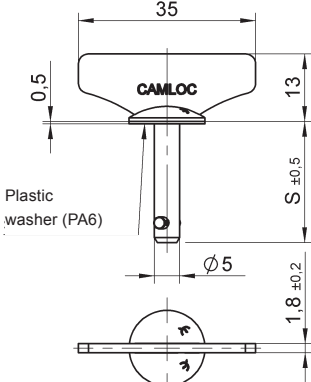
Other lengths on request.

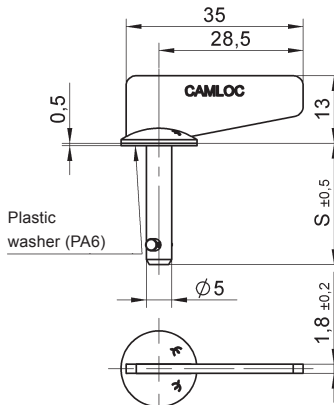
Style	Dimensions	Materials / Finish	°C	Part No.
<p>Slotted Recess Head</p> 	 <p>S = 11,40 + (0,6 x length no.)</p>	<p>Steel / zinc-plated, CrVI-free, clear passivation with plastic washer (PA6)</p> <p>Stainless steel with plastic washer (PA6)</p>	<p>80</p> <p>80</p>	<p>50E21-*AGV</p> <p>50E21-*S</p>
<p>Cross Recess Head</p> 	 <p>S = 11,40 + (0,6 x length no.)</p>	<p>Steel / zinc-plated, CrVI-free, clear passivation with plastic washer (PA6)</p>	<p>80</p>	<p>50E70-*AGV</p>
<p>Hex Head Slotted Recess</p> 	 <p>S = 11,40 + (0,6 x length no.)</p>	<p>Steel / zinc-plated, CrVI-free, clear passivation with plastic washer (PA6)</p>	<p>80</p>	<p>50E90-*AGV</p>

* Length no. from Table, see page D-1.

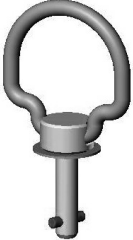
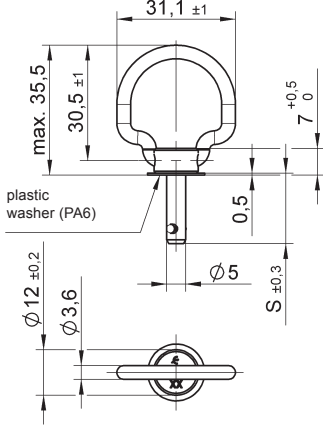
Style	Dimensions	Materials / Finish	°C	Part No.
<p>Hex Recess Head</p> 	 <p>$S = 11,40 + (0,6 \times \text{length no.})$</p>	Steel / zinc-plated, CrVI-free, clear passivation with plastic washer (PA6)	80	50E60-*AGV
<p>Fixed Wing Handle</p> 	 <p>$S = 11,40 + (0,6 \times \text{length no.})$</p>	Steel / zinc-plated, CrVI-free, clear passivation with plastic washer (PA6) Stainless steel with plastic washer (PA6)	80 80	50E21-*WAGV 50E21-*WS
<p>Offset Fixed Wing Handle</p> 	 <p>$S = 11,40 + (0,6 \times \text{length no.})$</p>	Steel / zinc-plated, CrVI-free, clear passivation with plastic washer (PA6)	80	50E21-*W0AGV

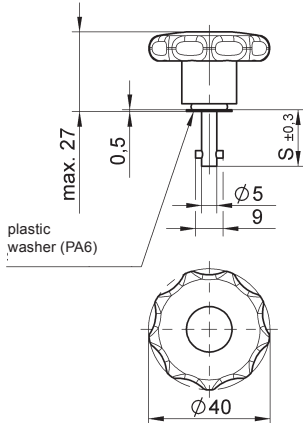
* Length no. from Table, see page D-1.

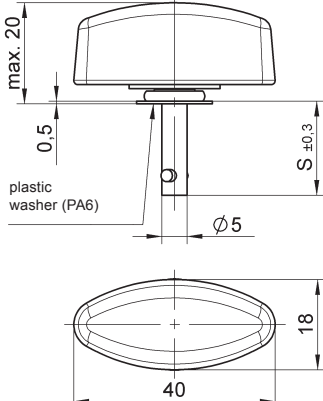
Style	Dimensions	Materials / Finish	°C	Part No.
Folding Bail Handle 180° 		Steel / zinc-plated, CrVI-free, clear passivation with plastic washer (PA6)	80	50E18-*AGV
Star Form Handle Plastic 		Steel / zinc-plated, CrVI-free, clear passivation with plastic head and plastic washer (PA6) Stainless steel with plastic head and plastic washer (PA6)	- 40 up to + 60 - 40 up to + 60	50E80-*AGV 50E80-*CP
Fixed Wing Handle Plastic 		Steel / zinc-plated, CrVI-free, clear passivation with plastic head and plastic washer (PA6) Stainless steel with plastic head and plastic washer (PA6)	- 40 up to + 60 - 40 up to + 60	50E82-*AGV 50E82-*CP

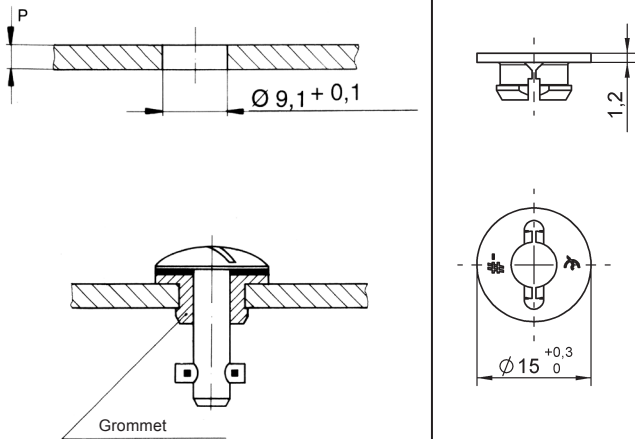
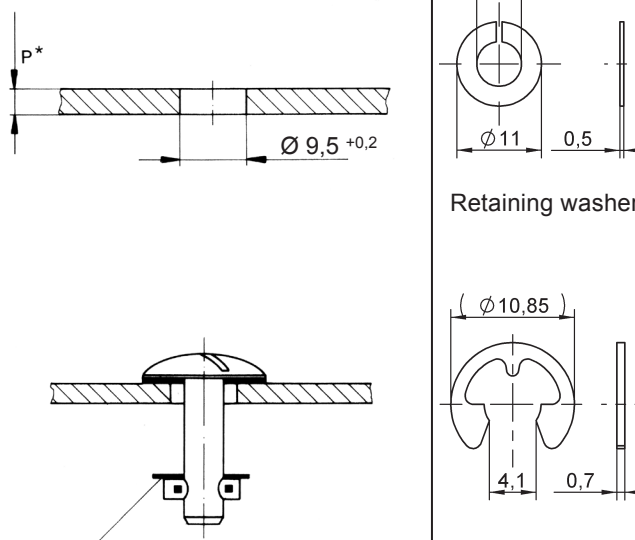

* Length no. from Table, see page D-1.

Style	Dimensions	Materials / Finish	P	Part No.
<p>Snap-In Grommet</p>  <p>Grommet</p>	Grommet	Plastic (PA6) / natural colour Working temperature: -40°C + 100°C	Up to 1,60	50S12-0-1AA
			1,70- 2,80	50S12-1-1AA
			2,90 - 4,00	50S12-2-1AA
			4,10 - 5,30	50S12-3-1AA
			5,40 - 6,65	50S12-4-1AA
<p>Retaining Washer</p>  <p>Retaining washer Installation: see page A-5.</p>	Retaining washer	Stainless steel		4002-SW-SS
	Retaining washer	Stainless steel		50E2-3BP
	Retaining washer	Plastic (PA6) / natural colour		50W204-01K

*For P up to 2mm Ø 8 +0,2 for installation without retaining washer

Working temperature:
-40°C + 120°C

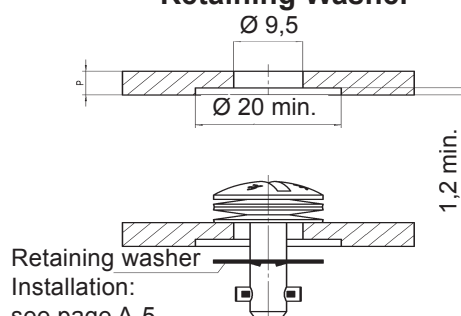
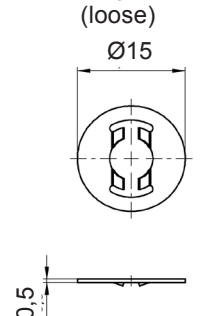
ADVANTAGE:
Plastic retaining washer can be assembled without tooling

<p>Retaining Washer</p> 	<p>Retaining washer (loose)</p> 	<p>Stainless steel</p>	<p>50W17-1BP</p>
	<p>Mounting tool for retaining washer 50W17-1BP</p>		<p>50T01-1DR</p>

Receptacles

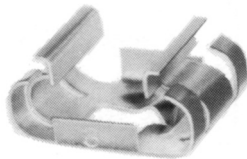
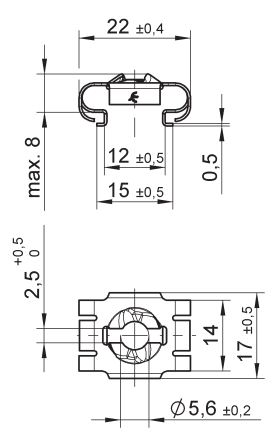
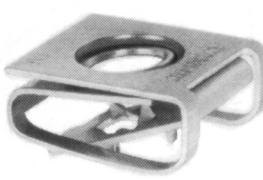
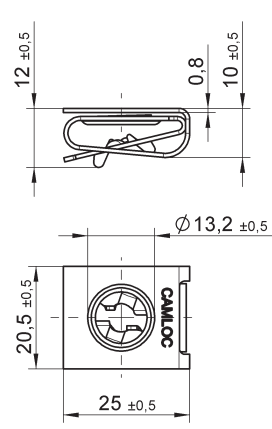
Style	Dimensions	Materials / Finish	Panel Thickness P	°C	Part No.
<p>Snap-In</p> 		<p>Spring steel / zinc-flake coated</p> <p>Spring steel / zinc-flake coated</p> <p>Max. tensile strength 250 N</p>	<p>F = 1,0 - 2,0</p>	<p>170</p>	<p>50E20-1AK7 (Type 1)</p>
<p>F = 2,1 - 3,0</p>	<p>170</p>	<p>50E20-2AK7 (Type 2)</p>			
<p>Clip-On</p> 		<p>Spring steel / zinc-flake coated</p>	<p>F = 0,8 - 5,6</p>	<p>170</p>	<p>V50R4-2-1AK7 (Type 3)</p>

Receptacle Installation Instructions

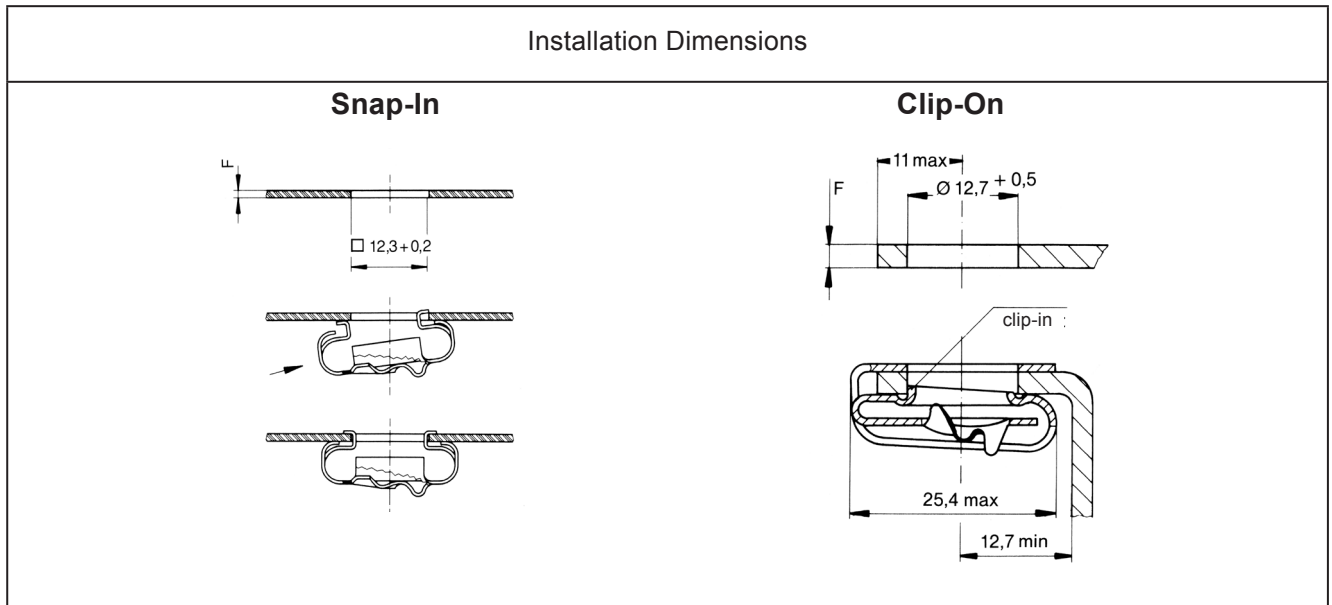

Features

- Max. tensile strength 3.700 N, working load 2.600 N.
- Small fastener giving high tensile load.
- Flat receptacle.
- High preload.

Selection Instructions



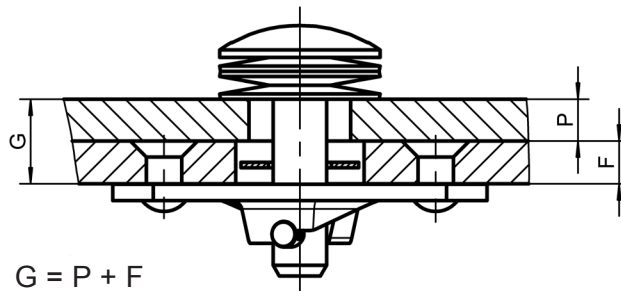

1. Select stud assembly and receptacle, page E-2 to E-4 and E-6.
2. Select retaining washer, page E-5.
3. Select stud length number from total thickness G using the formula and table below (e.g. 50E8-*AGV).



Stud Length Table

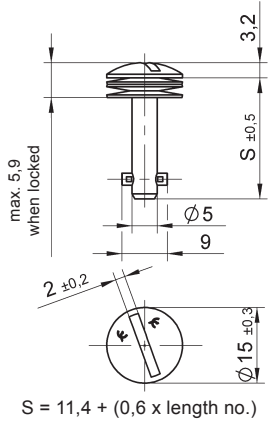

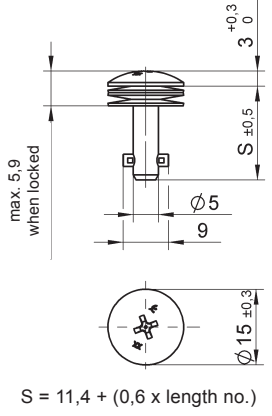

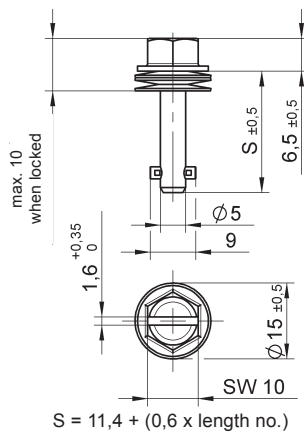
Total Thickness G	Stud Length No.	Total Thickness G	Stud Length No.
0,50 - 1,10	2	10,70 - 11,30	19
1,10 - 1,70	3	11,30 - 11,90	20
1,70 - 2,30	4	11,90 - 12,50	21
2,30 - 2,90	5	12,50 - 13,10	22
2,90 - 3,50	6	13,10 - 13,70	23
3,50 - 4,10	7	13,70 - 14,30	24
4,10 - 4,70	8	14,30 - 14,90	25
4,70 - 5,30	9	14,90 - 15,50	26
5,30 - 5,90	10	15,50 - 16,10	27
5,90 - 6,50	11	16,10 - 16,70	28
6,50 - 7,10	12	16,70 - 17,30	29
7,10 - 7,70	13	17,30 - 17,90	30
7,70 - 8,30	14	17,90 - 18,50	31
8,30 - 8,90	15	18,50 - 19,10	32
8,90 - 9,50	16	19,10 - 19,70	33
9,50 - 10,10	17	19,70 - 20,30	34
10,10 - 10,70	18	20,30 - 20,90	35

Other lengths on request.

Style	Dimensions	Materials / Finish	°C	Part No.
<p>Slotted Recess Head</p> 	 <p>$S = 11,4 + (0,6 \times \text{length no.})$</p>	<p>Steel / zinc-plated, CrVI-free, clear passivation</p> <p>Stainless steel ¹⁾</p>	<p>120</p> <p>200</p>	<p>50E8-*AGV</p> <p>50E8-*S</p>
<p>Cross Recess Head</p> 	 <p>$S = 11,4 + (0,6 \times \text{length no.})$</p>	<p>Steel / zinc-plated, CrVI-free, clear passivation</p>	<p>120</p>	<p>50E71-*AGV</p>
<p>Hex Head Slotted Recess</p> 	 <p>$S = 11,4 + (0,6 \times \text{length no.})$</p>	<p>Steel / zinc-plated, CrVI-free, clear passivation</p>	<p>120</p>	<p>50E91-*AGV</p>

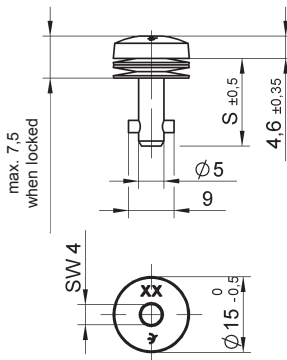

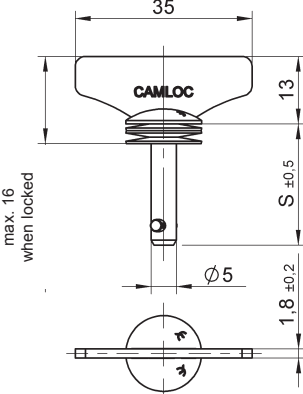

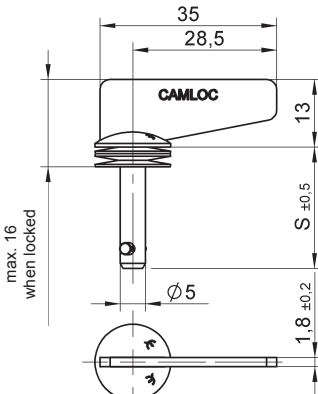
* Length no. from Table, page E-1.

¹⁾Max. tensile strength 2.600 N, working load 1.700 N.

Style	Dimensions	Materials / Finish	°C	Part No.
<p>Hex Recess Head</p> 	 <p>$S = 11,4 + (0,6 \times \text{length no.})$</p>	Steel / zinc-plated, CrVI-free, clear passivation	120	50E61-*AGV
<p>Fixed Wing Handle</p> 	 <p>$S = 11,4 + (0,6 \times \text{length no.})$</p>	Steel / zinc-plated, CrVI-free, clear passivation Stainless steel ¹⁾	120 200	50E8-*WAGV 50E8-*WS
<p>Offset Fixed Wing Handle</p> 	 <p>$S = 11,4 + (0,6 \times \text{length no.})$</p>	Steel / zinc-plated, CrVI-free, clear passivation Stainless steel ¹⁾	120 200	50E8-*W0AGV 50E8-*W0S

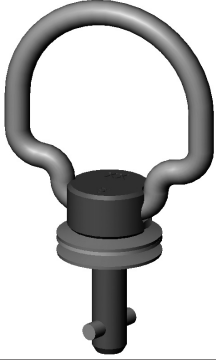
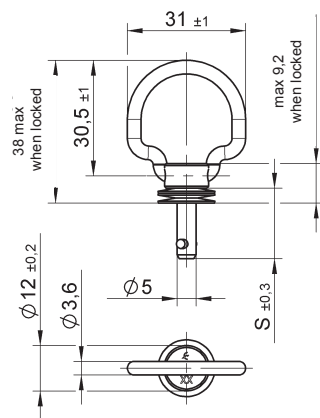
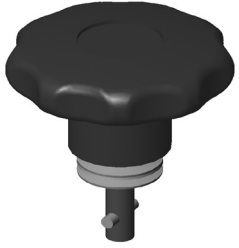
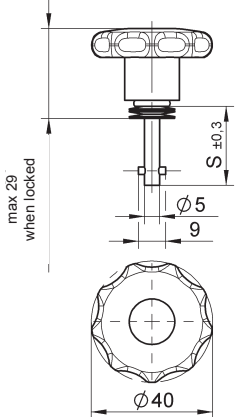

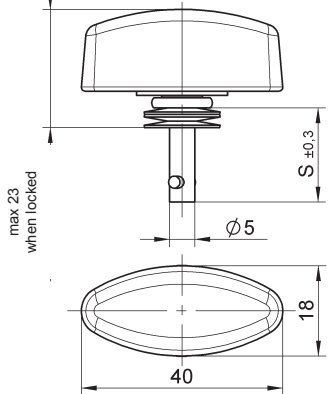
* Length no. from Table, page E-1.

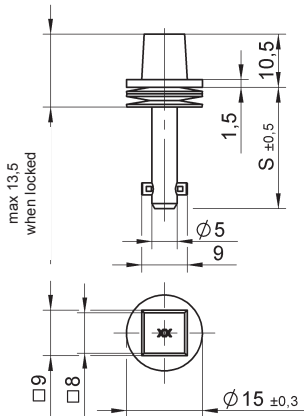
¹⁾ Max. tensile strength 2.600 N, working load 1.700 N.

Style	Dimensions	Materials / Finish	°C	Part No.
Folding Bail Handle 180° 		Steel / zinc-plated, CrVI-free, clear passivation	120	50E19-*AGV
Star Form Handle Plastic 		Steel / zinc-plated, CrVI-free, clear passivation with plastic knob (PA 6) Stainless steel ¹⁾ with plastic knob	-40 up to +60 -40 up to +60	50E81-*AGV 50E81-*CP
Fixed Wing Handle Plastic 		Steel / zinc-plated, CrVI-free, clear passivation with plastic knob (PA 6) Stainless steel ¹⁾ with plastic knob	-40 up to +60 -40 up to +60	50E83-*AGV 50E83-*CP
Square Head 		Steel / zinc-plated, CrVI-free, clear passivation	120	50E7-*AGV

* Length no. from Table, page E-1.

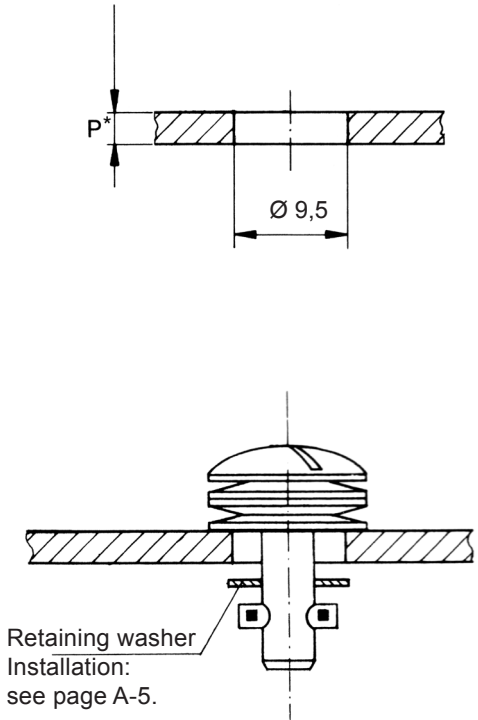
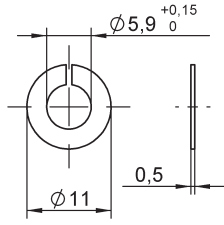
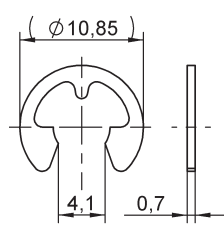
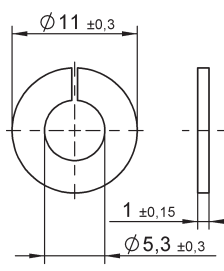
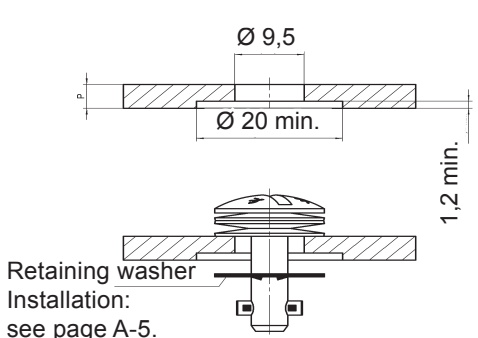
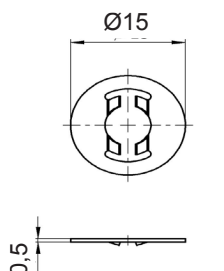
¹⁾ Max. tensile strength 2.600 N, working load 1.700 N.

Installation Dimensions	Accessories	Material / Finish	Part No.
 <p>Retaining washer Installation: see page A-5.</p>	<p>Retaining washer (loose)</p>  <p>Retaining washer (fixed)</p>  <p>Retaining washer (loose)</p> 	<p>Stainless steel</p> <p>Stainless steel</p> <p>Plastic (PA6) / natural colour</p> <p>Working temperature: -40°C + 120°C</p> <p>ADVANTAGE: Plastic retaining washer to be assembled without tooling.</p>	<p>4002-SW-SS</p> <p>50E2-3BP</p> <p>50W204-01K</p>
<p>*For P up to 2 mm Ø 8 +0,2 for installation without retaining washer</p>  <p>Retaining washer Installation: see page A-5.</p>	<p>Retaining washer (loose)</p> 	<p>Stainless steel</p>	<p>50W17-1BP</p>
	<p>Mounting tool for retaining washer 50W17-1BP</p>	<p>50T01-1DR</p>	

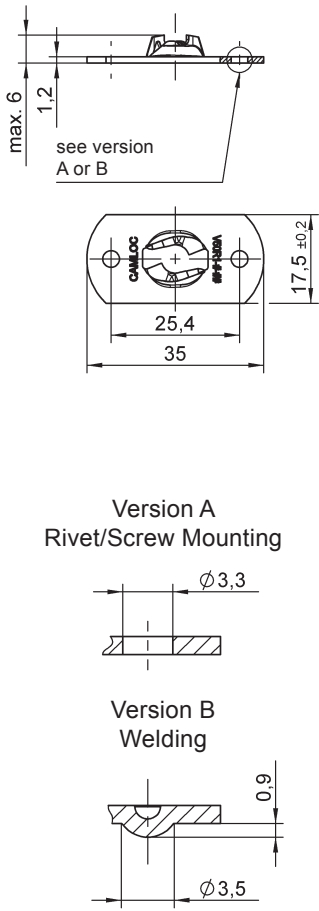
Style	Dimensions	Materials / Finish	°C	Part No.
Rivet- / Screw or Weld Mounting 		Rivet / Screw Mounting Steel / zinc-plated, CrVI-free, clear passivation	120	V50R1-1-1AGV
		Stainless steel	200	V50R1-1-1BP
		Welding Steel / zinc-plated	-	V50R1-1-2AZ
		Steel / oil coated	-	V50R1-1-2AR

Receptacle Installation Instructions

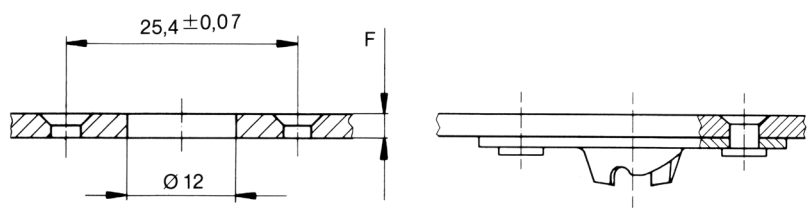
Installation Dimensions
<p align="center">Rivet- / Screw or Weld Mounting</p> 

Features

Max. tensile strength 1.330 N, working load 900 N.

Small fastener giving a high tensile load.

Wide range of stud head styles and receptacles.

Selection Instructions

1. Select stud assembly and receptacle, page F-3 up to F-5, F-7 up to F-10.
2. Select stud accessories (retaining washer, gasket), page F-6 and F-7.
3. Select hex nut for receptacle, if necessary, page F-11.
4. Select stud length number from total thickness G using the formula and table on page F-2 (e.g. V26S01-*AGV).

Determining the stud length number when using receptacle:

Type 1 + 3*

$$G = P + F$$

* For Type 3: G = 9,9 mm min.

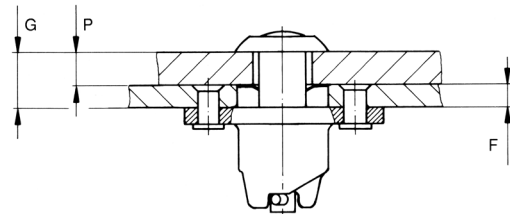

Type 2

$$G = P + F \text{ (0,75 min.)}$$

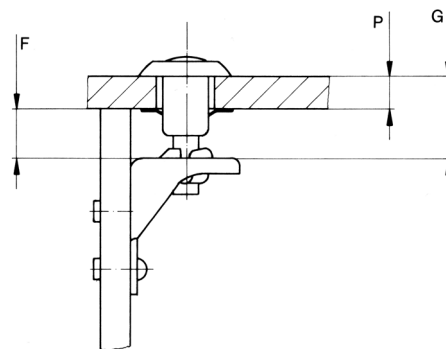



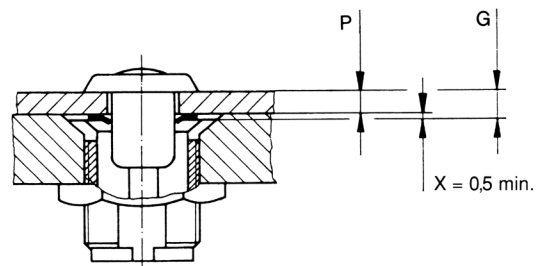

Type 4

$$G = P + X \text{ (0,5 min.)}$$



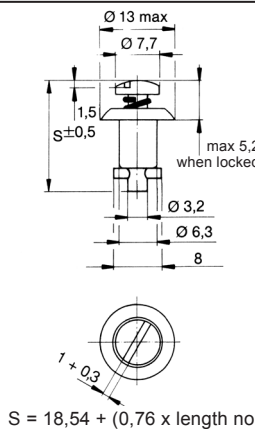

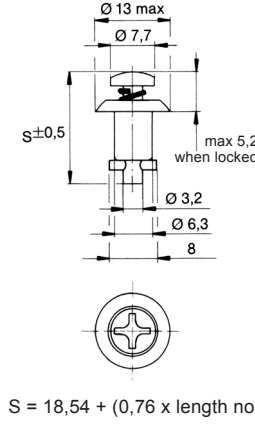
Total Thickness G	Stud Length No. When Using Type 1 + 4 Receptacles	Total Thickness G	Stud Length No. When Using Type 2 Receptacles	Total Thickness G	Stud Length No. When Using Type 3 Receptacles
0,75 - 1,50	1	0,75 - 1,50	2	9,90 - 10,65	1
1,50 - 2,30	2	1,50 - 2,30	3	10,65 - 11,40	2
2,30 - 3,05	3	2,30 - 3,05	4	11,40 - 12,20	3
3,05 - 3,80	4	3,05 - 3,80	5	12,20 - 12,95	4
3,80 - 4,60	5	3,80 - 4,60	6	12,95 - 13,70	5
4,60 - 5,35	6	4,60 - 5,35	7	13,70 - 14,50	6
5,35 - 6,10	7	5,35 - 6,10	8	14,50 - 15,25	7
6,10 - 6,85	8	6,10 - 6,85	9	15,25 - 16,00	8
6,85 - 7,60	9	6,85 - 7,60	10	16,00 - 16,75	9
7,60 - 8,40	10	7,60 - 8,40	11	16,75 - 17,50	10
8,40 - 9,15	11	8,40 - 9,15	12	17,50 - 18,30	11
9,15 - 9,90	12	9,15 - 9,90	13	18,30 - 19,05	12
9,90 - 10,65	13	9,90 - 10,65	14	19,05 - 19,80	13
10,65 - 11,40	14	10,65 - 11,40	15	19,80 - 20,60	14
11,40 - 12,20	15	11,40 - 12,20	16	20,60 - 21,35	15
12,20 - 12,95	16	12,20 - 12,95	17	21,35 - 22,10	16
12,95 - 13,70	17	12,95 - 13,70	18	22,10 - 22,85	17
13,70 - 14,50	18	13,70 - 14,50	19	22,85 - 23,60	18
14,50 - 15,25	19	14,50 - 15,25	20	23,60 - 24,40	19
15,25 - 16,00	20	15,25 - 16,00	21	24,40 - 25,15	20
16,00 - 16,75	21	16,00 - 16,75	22	25,15 - 25,90	21
16,75 - 17,50	22	16,75 - 17,50	23	25,90 - 26,65	22
17,50 - 18,30	23	17,50 - 18,30	24	26,65 - 27,40	23
18,30 - 19,05	24	18,30 - 19,05	25	27,40 - 28,20	24
19,05 - 19,80	25	19,05 - 19,80	26	28,20 - 28,95	25
19,80 - 20,60	26	19,80 - 20,60	27	28,95 - 29,70	26
20,60 - 21,35	27	20,60 - 21,35	28	29,70 - 30,50	27
21,35 - 22,10	28	21,35 - 22,10	29	30,50 - 31,25	28
22,10 - 22,85	29	22,10 - 22,85	30	31,25 - 32,00	29
22,85 - 23,60	30	22,85 - 23,60	31	32,00 - 32,75	30
23,60 - 24,40	31	23,60 - 24,40	32	32,75 - 33,50	31
24,40 - 25,15	32	24,40 - 25,15	33	33,50 - 34,30	32
25,15 - 25,90	33	25,15 - 25,90	34	34,30 - 35,05	33
25,90 - 26,65	34	25,90 - 26,65	35	35,05 - 35,80	34
26,65 - 27,40	35	26,65 - 27,40	36	35,80 - 36,60	35
27,40 - 28,20	36	27,40 - 28,20	37	36,60 - 37,35	36
28,20 - 28,95	37	28,20 - 28,95	38	37,35 - 38,10	37
28,95 - 29,70	38	28,95 - 29,70	39	38,10 - 38,85	38
29,70 - 30,50	39	29,70 - 30,50	40	38,85 - 39,60	39
30,50 - 31,25	40	29,70 - 30,50	40	39,60 - 40,40	40

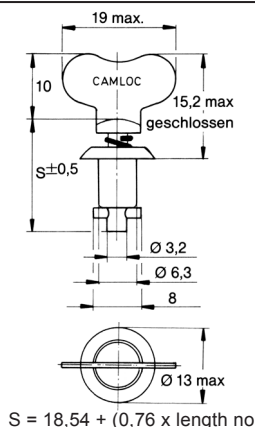
Other lengths on request.

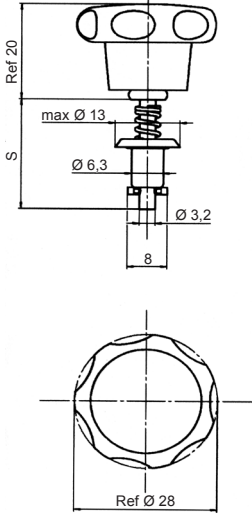

Style	Dimensions	Materials / Finish	°C	Part No.
Slotted Recess Pan Head 	 <p>S = 18,54 + (0,76 x length no.)</p>	Steel / zinc-plated, CrVI-free, clear passivation	120	V26S01-*AGV
		Steel / chrome-plated	120	26S38-*
		Stainless steel ¹⁾	200	2600-*S
		Steel / nickel-plated	120	26S42-*
Cross Recess Pan Head 	 <p>S = 18,54 + (0,76 x length no.)</p>	Steel / zinc-plated, CrVI-free, clear passivation	120	V26S02-*AGV
		Steel / nickel-plated	120	26S39-*
		Stainless steel ¹⁾	200	26S51-*
Fixed Wing Handle 	 <p>S = 18,54 + (0,76 x length no.)</p>	Steel / zinc-plated, CrVI-free, clear passivation	120	V26S04-*AGV
		Stainless steel ¹⁾	200	2600-*SW

* Length no. from Table, page F-2.

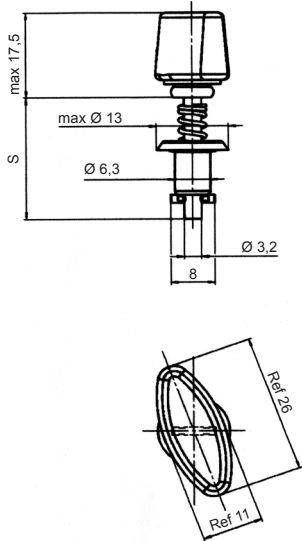
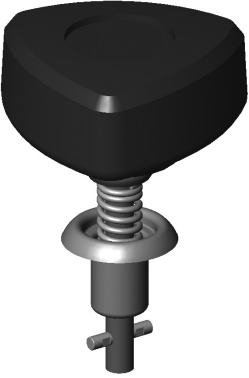
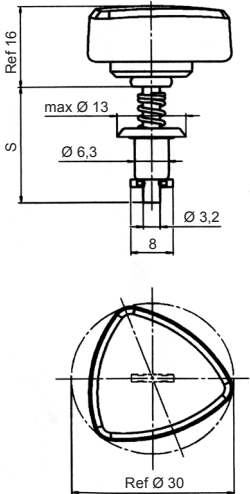

¹⁾ Max. Tensile strength 1.000 N, working load 700 N.

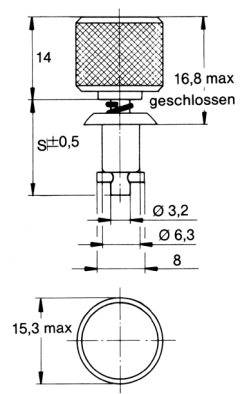
Style	Dimensions	Materials / Finish	°C	Part No.
<p>Star Form Handle Plastic</p> 		<p>Steel / zinc-plated, CrVI-free, clear passivation with plastic knob (PA6)</p> <p>Note: Not to be used with encapsulated receptacles</p>	-40 up to +60	V26S06- *AGV
<p>Fixed Wing Handle Plastic</p> 		<p>Steel / zinc-plated, CrVI-free, clear passivation with plastic knob (PA6)</p> <p>Note: Not to be used with encapsulated receptacles</p>	-40 up to +60	V26S07- *AGV
<p>Triangular Handle Plastic</p> 		<p>Steel / zinc-plated, CrVI-free, clear passivation with plastic knob (PA6)</p> <p>Note: Not to be used with encapsulated receptacles</p>	-40 up to +60	V26S08- *AGV

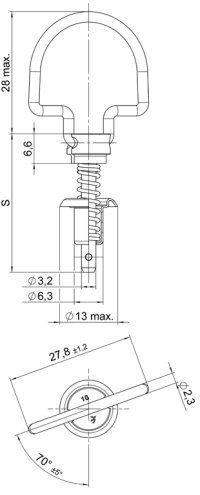
* Length no. from Table, page F-2.

Style	Dimensions	Materials / Finish	°C	Part No.
<p>Knurled Head</p> 	 <p>S = 16,76 + (0,76 x length no.)</p>	Steel / chrome-plated	120	26S34-*
<p>Folding Bail Handle 180°</p> 		Steel / zinc-plated, CrVI-free, clear passivation	120	V26S22 - *AGV

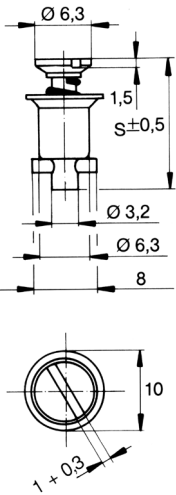
* Length no. from Table, page F-2.

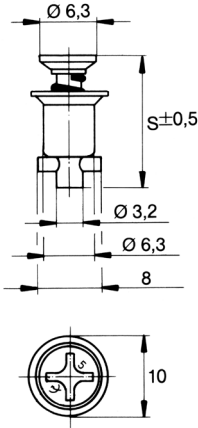



Style	Dimensions	Materials / Finish	°C	Part No.
<p>Slotted Recess Flush Head</p> 	 <p>$S = 14,73 + (0,76 \times \text{length no.})$</p>	<p>Steel / zinc-plated, CrVI-free, clear passivation</p> <p>Stainless steel ¹⁾</p>	<p>120</p> <p>200</p>	<p>V27S01-*AGV</p> <p>2700-*S</p>
<p>Cross Recess Flush Head</p> 	 <p>$S = 14,73 + (0,76 \times \text{length no.})$</p>	<p>Steel / zinc-plated, CrVI-free, clear passivation</p>	<p>120</p>	<p>V27S02-*AGV</p>

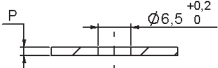
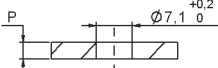
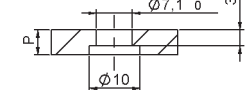
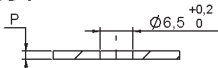
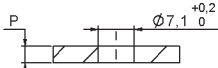
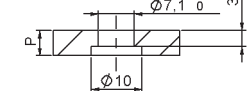
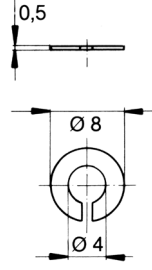
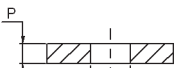
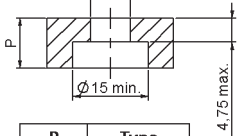
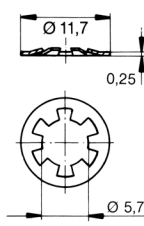
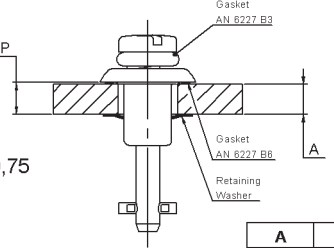
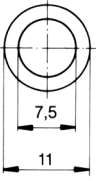
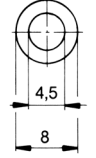

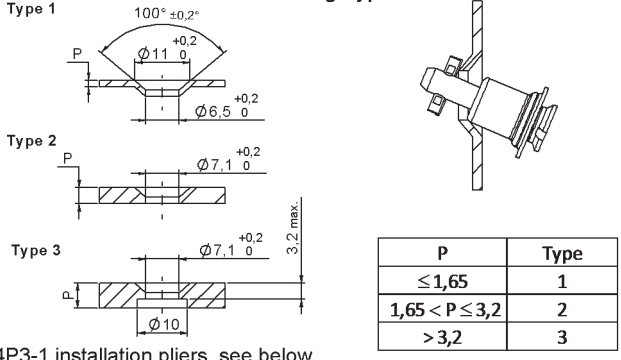
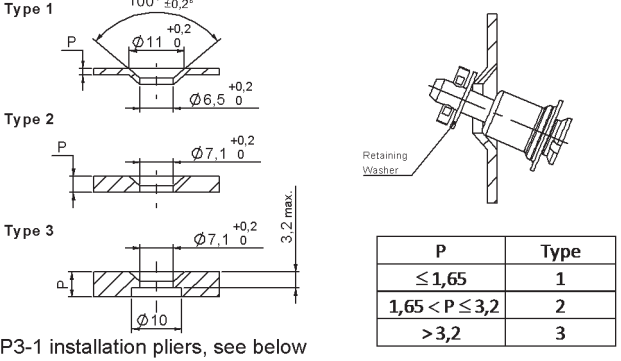
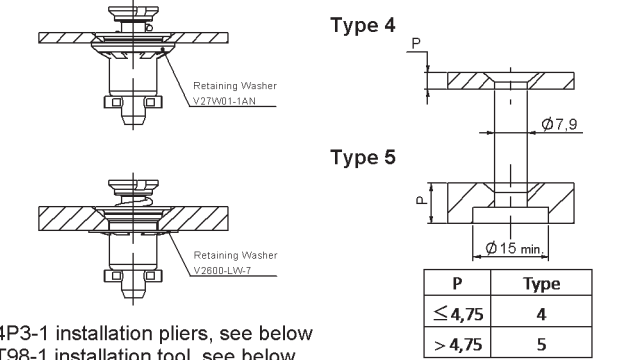
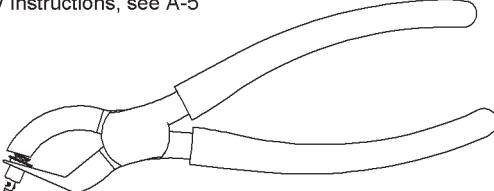
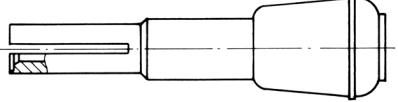
* Length no. from Table, page F-2.

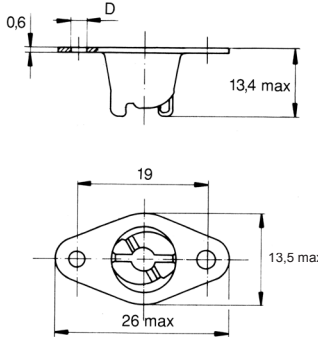

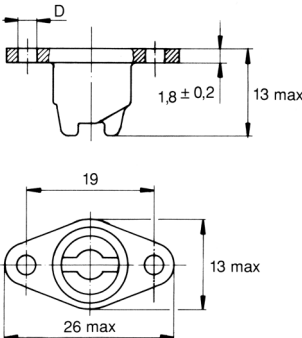
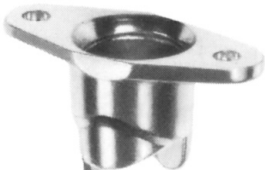
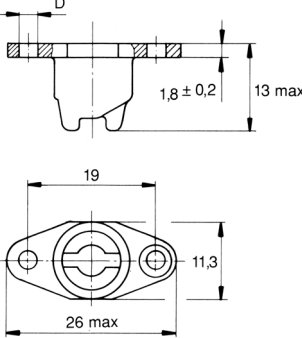
¹⁾Max. Tensile strength 1.000 N, working load 700

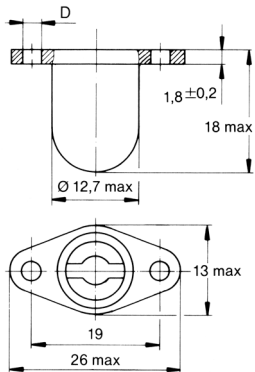
Installation Dimensions	Accessories	Material / Finish	Part No.								
<p>Stud Retention up to Dash No. 4 without Retaining Washer Floating Type</p> <p>Type 1 </p> <p>Type 2 </p> <p>Type 3 </p> <table border="1" data-bbox="550 604 790 728"> <thead> <tr> <th>P</th> <th>Type</th> </tr> </thead> <tbody> <tr> <td>≤ 1,65</td> <td>1</td> </tr> <tr> <td>1,65 < P ≤ 3,2</td> <td>2</td> </tr> <tr> <td>> 3,2</td> <td>3</td> </tr> </tbody> </table> <p>4P3-1 installation pliers, see F-8</p>	P	Type	≤ 1,65	1	1,65 < P ≤ 3,2	2	> 3,2	3	-	-	-
P	Type										
≤ 1,65	1										
1,65 < P ≤ 3,2	2										
> 3,2	3										
<p>Stud Retention from Dash No. 5 with Retaining Washer Floating Type</p> <p>Type 1 </p> <p>Type 2 </p> <p>Type 3 </p> <table border="1" data-bbox="550 1041 805 1164"> <thead> <tr> <th>P</th> <th>Type</th> </tr> </thead> <tbody> <tr> <td>≤ 1,65</td> <td>1</td> </tr> <tr> <td>1,65 < P ≤ 3,2</td> <td>2</td> </tr> <tr> <td>> 3,2</td> <td>3</td> </tr> </tbody> </table> <p>4P3-1 installation pliers, see F-8</p>	P	Type	≤ 1,65	1	1,65 < P ≤ 3,2	2	> 3,2	3	Retaining washer 	Stainless steel	2600-SW
P	Type										
≤ 1,65	1										
1,65 < P ≤ 3,2	2										
> 3,2	3										
<p>Stud Retention with Retaining Washer Fixed installed</p> <p>Type 4 </p> <p>Type 5 </p> <table border="1" data-bbox="598 1523 774 1612"> <thead> <tr> <th>P</th> <th>Type</th> </tr> </thead> <tbody> <tr> <td>≤ 4,75</td> <td>4</td> </tr> <tr> <td>> 4,75</td> <td>5</td> </tr> </tbody> </table> <p>4P3-1 installation pliers, see F-8 T98-1 installation tool, siehe F-8</p>	P	Type	≤ 4,75	4	> 4,75	5	Retaining washer 	Stainless steel Not for chrome-plated parts	V2600-LW-7		
P	Type										
≤ 4,75	4										
> 4,75	5										
<p>Series 2600 Sealed only for Recess Types Slotted or Cross only in combination with Retaining Washer V2600-LW-7</p> <p></p> <p>$P = A + 0,75$</p> <table border="1" data-bbox="598 1960 774 2049"> <thead> <tr> <th>A</th> <th>Type</th> </tr> </thead> <tbody> <tr> <td>≤ 4,00</td> <td>4</td> </tr> <tr> <td>> 4,00</td> <td>5</td> </tr> </tbody> </table> <p>4P3-1 installation pliers, see F-8 T98-1 installation tool, siehe F-8</p>	A	Type	≤ 4,00	4	> 4,00	5	Gaskets  	Rubber (100°C) Rubber (100°C)	AN6227-B6 AN6227-B3		
A	Type										
≤ 4,00	4										
> 4,00	5										

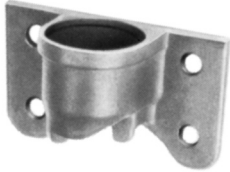
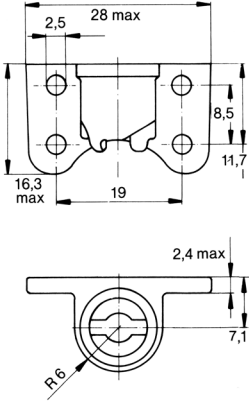
Installation Dimensions	Accessories	Material / Finish	Part No.								
<p>Stud Retention up to Dash No. 4 without Retaining Washer Floating Type</p>  <table border="1" data-bbox="510 604 758 716"> <thead> <tr> <th>P</th> <th>Type</th> </tr> </thead> <tbody> <tr> <td>≤ 1,65</td> <td>1</td> </tr> <tr> <td>1,65 < P ≤ 3,2</td> <td>2</td> </tr> <tr> <td>> 3,2</td> <td>3</td> </tr> </tbody> </table> <p>4P3-1 installation pliers, see below</p>	P	Type	≤ 1,65	1	1,65 < P ≤ 3,2	2	> 3,2	3	-	-	-
P	Type										
≤ 1,65	1										
1,65 < P ≤ 3,2	2										
> 3,2	3										
<p>Stud Retention from Dash No. 5 with Retaining Washer Floating Type</p>  <table border="1" data-bbox="510 1052 758 1164"> <thead> <tr> <th>P</th> <th>Type</th> </tr> </thead> <tbody> <tr> <td>≤ 1,65</td> <td>1</td> </tr> <tr> <td>1,65 < P ≤ 3,2</td> <td>2</td> </tr> <tr> <td>> 3,2</td> <td>3</td> </tr> </tbody> </table> <p>4P3-1 installation pliers, see below</p>	P	Type	≤ 1,65	1	1,65 < P ≤ 3,2	2	> 3,2	3	Retaining washer	Stainless steel	2600-SW
P	Type										
≤ 1,65	1										
1,65 < P ≤ 3,2	2										
> 3,2	3										
<p>Stud Retention with Retaining Washer Fixed installed</p>  <table border="1" data-bbox="558 1512 726 1601"> <thead> <tr> <th>P</th> <th>Type</th> </tr> </thead> <tbody> <tr> <td>≤ 4,75</td> <td>4</td> </tr> <tr> <td>> 4,75</td> <td>5</td> </tr> </tbody> </table> <p>4P3-1 installation pliers, see below T98-1 installation tool, see below</p>	P	Type	≤ 4,75	4	> 4,75	5	Retaining washer	Stainless steel Steel / nickel-plated	V2600-LW-7 V27W01-1AN		
P	Type										
≤ 4,75	4										
> 4,75	5										
<p>Assembly Instructions, see A-5</p> 	Stud Installation pliers		4P3-1								
<p>Assembly Instructions, see A-5</p> 	V2600-LW-7 and V27W01-1AN retaining washer installation tool		T98-1								

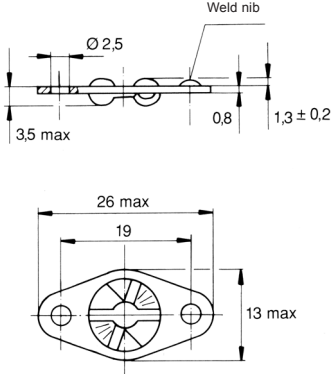
Style	Dimensions	Materials / Finish	D	°C	Part No.
<p>Type 1 Lightweight</p> 		Steel / zinc-plated, CrVI-free, clear passivation	2,6	120	V26R6-1AGV
<p>Type 1 Cast</p> 		<p>Hard bronze / zinc-plated, CrVI-free, clear passivation</p> <p>Hard bronze / zinc-plated, CrVI-free, clear passivation</p> <p>Stainless steel</p>	<p>2,5</p> <p>3,3</p> <p>2,5</p>	<p>120</p> <p>120</p> <p>200</p>	<p>V212-12-1FGV</p> <p>V212-12-2FGV</p> <p>212-12S</p>
<p>Type 1 Narrow Width</p> 		Hard bronze / zinc-plated, CrVI-free, clear passivation	2,5	120	V212-12N-1FGV
<p>Type 1 Encapsulated</p> 		<p>Hard bronze / zinc-plated, CrVI-free, clear passivation</p> <p>Capsule: Steel / zinc-plated, CrVI-free, clear passivation</p> <p>Stainless steel</p>	<p>2,5</p> <p>2,5</p>	<p>120</p> <p>150</p>	<p>26R16-1FGV</p> <p>26R18-1-1AA</p>

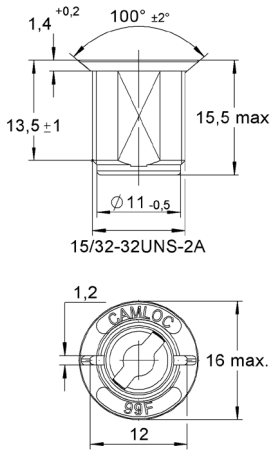
Style	Dimensions	Materials / Finish	°C	Part No.
<p>Type 2 Side Mounting</p> 		<p>Aluminium / anodized</p>	<p>175</p>	<p>26R1-1</p>
<p>Type 3 Rivet / Screw or Weld Mounting</p> 		<p>Rivet / Screw Mounting Steel / zinc-plated, CrVI-free, clear passivation</p> <p>Stainless steel</p> <p>Welding Stainless steel</p>	<p>120</p> <p>200</p> <p>-</p>	<p>V312-12AGV</p> <p>312-12S</p> <p>312-12WS</p>

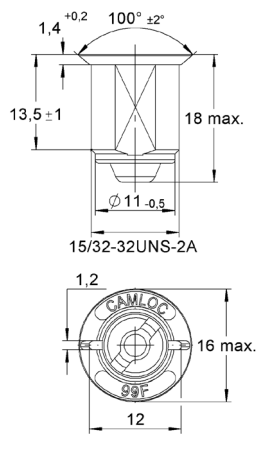
Style	Dimensions	Materials / Finish	°C	Part No.
<p>Type 4 Single Hole Mounting</p> 		<p>Zinc die cast / zinc-plated, CrVI-free, clear chromate</p>	<p>100</p>	<p>99R10-01A1</p>
<p>Type 4 Single Hole Mounting Encapsulated</p> 		<p>Zinc die cast / zinc-plated, CrVI-free, clear chromate</p> <p>Capsule: Stainless steel</p>	<p>100</p>	<p>99E10-01</p>

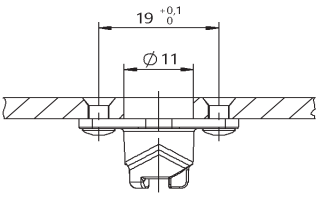
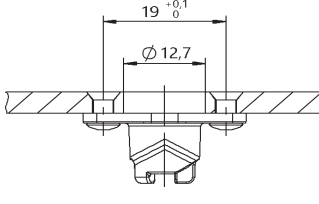
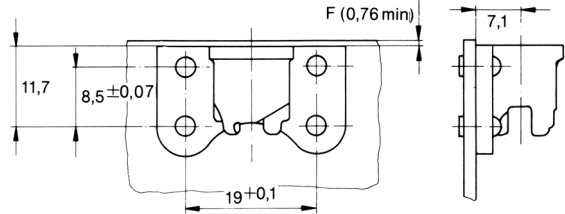
Installation Dimensions	
<p>Type 1 + 3 Receptacles Hole Pattern when using the retaining washer 2600-SW</p> 	<p>Type 1 + 3 Receptacles Hole Pattern when using the retaining washer V2600-LW-7</p> 
<p>Type 2 Receptacle Hole Pattern (Side Mounting)</p> 	

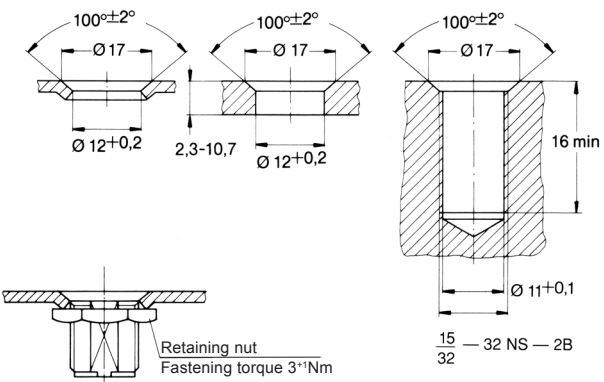
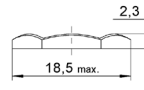
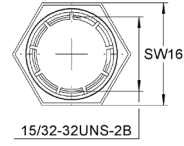
Installation Dimensions	Accessories	Materials / Finish	Part No.
<p>Installation Options Type 4 Receptacle</p>  <p>Retaining nut Fastening torque 3⁺Nm</p> <p>15 / 32 NS — 2B</p>	<p>Retaining nut</p>   <p>15 / 32 — 32 NS — 2B</p> <p>Tap</p>	<p>Steel / zinc-plated, CrVI-free, clear chromate</p>	<p>99N10-01A1</p> <p>15/32-32NS-2B</p>

Features

Max. tensile strength 4.700 N, working load 3.100 N.

Small fastener for high tensile load.

Large range of stud assemblies with fixed and floating receptacles

Selection Instructions

1. Select stud assembly, page G-4 and G-5, grommet and snap-on retaining ring, page G-7 and receptacle, page G-8 and G-9.
2. Select retaining washer, page G-6, for studs from length no. 5.
3. Select stud length number from total thickness G using the formula and the table on page G-2 and G-3 (e.g. D4002-*AGV).

Determining the stud length number when using receptacle:

Standard version

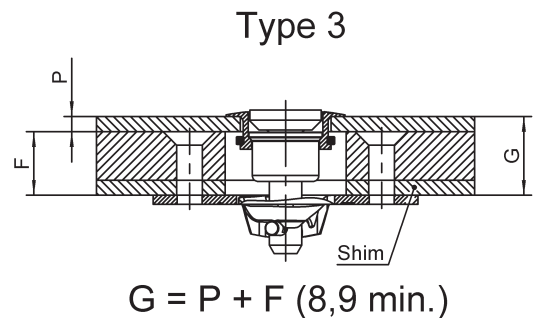
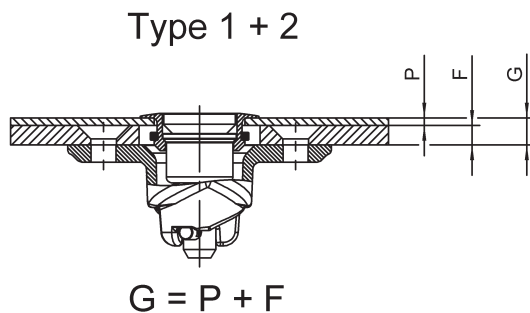

Sealed version

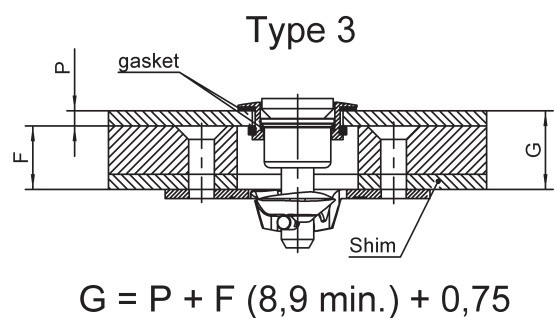
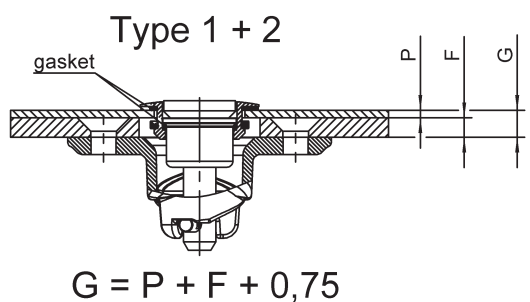

**When Using the Following Grommet and Receptacles:
Flush Mounting Grommets
D4002-G-AGV D4002-H-AGV
4002-GS 4002-HS**





Stud Length No. When Using

Total Thickness G	Type 1 Receptacles	Type 2 Receptacles	Type 3 Receptacles	Total Thickness G	Type 1 Receptacles	Type 2 Receptacles	Type 3 Receptacles
0,50 - 1,30	-	-	-	27,20 - 27,95	35	36	26
1,30 - 2,05	-	-	-	27,95 - 28,70	36	37	27
2,05 - 2,80	-	3	-	28,70 - 29,50	37	38	28
2,80 - 3,55	3	4	-	29,50 - 30,20	38	39	29
3,55 - 4,30	4	5	-	30,20 - 31,00	39	40	30
4,30 - 5,10	5	6	-	31,00 - 31,75	40	41	31
5,10 - 5,85	6	7	-	31,75 - 32,50	41	42	32
5,85 - 6,60	7	8	-	32,50 - 33,30	42	43	33
6,60 - 7,30	8	9	-	33,30 - 34,05	43	44	34
7,30 - 8,15	9	10	-	34,05 - 34,80	44	45	35
8,15 - 8,90	10	11	-	34,80 - 35,55	45	46	36
8,90 - 9,65	11	12	-	35,55 - 36,30	46	47	37
9,65 - 10,40	12	13	3	36,30 - 37,10	47	48	38
10,40 - 11,20	13	14	4	37,10 - 37,85	48	49	39
11,20 - 11,95	14	15	5	37,85 - 38,60	49	50	40
11,95 - 12,70	15	16	6	38,60 - 39,35	50	51	41
12,70 - 13,50	16	17	7	39,35 - 40,10	51	52	42
13,50 - 14,20	17	18	8	40,10 - 40,90	52	53	43
14,20 - 15,00	18	19	9	40,90 - 41,65	53	54	44
15,00 - 15,75	19	20	10	41,65 - 42,40	54	55	45
15,75 - 16,50	20	21	11	42,40 - 43,15	55	56	46
16,50 - 17,30	21	22	12	43,15 - 43,90	56	57	47
17,30 - 18,00	22	23	13	43,90 - 44,70	57	58	48
18,00 - 18,80	23	24	14	44,70 - 45,45	58	59	49
18,80 - 19,55	24	25	15	45,45 - 46,20	59	60	50
19,55 - 20,30	25	26	16	46,20 - 46,95	60	-	51
20,30 - 21,10	26	27	17	46,95 - 47,70	-	-	52
21,10 - 21,85	27	28	18	47,70 - 48,50	-	-	53
21,85 - 22,60	28	29	19	48,50 - 49,25	-	-	54
22,60 - 23,40	29	30	20	49,25 - 50,00	-	-	55
23,40 - 24,15	30	31	21	50,00 - 50,75	-	-	56
24,15 - 24,90	31	32	22	50,75 - 51,50	-	-	57
24,90 - 25,65	32	33	23	51,50 - 52,30	-	-	58
25,65 - 26,40	33	34	24	52,30 - 53,05	-	-	59
26,40 - 27,20	34	35	25	53,05 - 53,80	-	-	60

Other Lengths on request.

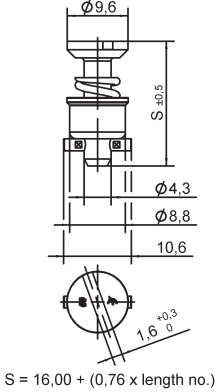

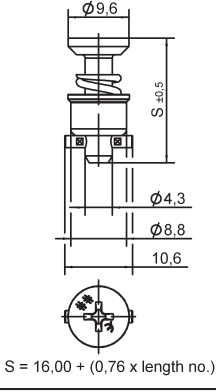
When Using the Following Grommet and Receptacles: Plus Flush Mounting Grommets							
D4002-N-AGV D4002-O-AGV D4002-P-AGV D4002-R-AGV D4002-S-AGV D4002-T-AGV 4002-NS 4002-OS D4002-P-BP D4002-R-BP D4002-S-BP D4002-T-BP							
Stud Length No. When Using							
Total Thickness G	Type 1 Receptacles	Type 2 Receptacles	Type 3 Receptacles	Total Thickness G	Type 1 Receptacles	Type 2 Receptacles	Type 3 Receptacles
0,50 - 1,30	-	-	-	27,20 - 27,95	36	37	27
1,30 - 2,05	-	3	-	27,95 - 28,70	37	38	28
2,05 - 2,80	3	4	-	28,70 - 29,50	38	39	29
2,80 - 3,55	4	5	-	29,50 - 30,20	39	40	30
3,55 - 4,30	5	6	-	30,20 - 31,00	40	41	31
4,30 - 5,10	6	7	-	31,00 - 31,75	41	42	32
5,10 - 5,85	7	8	-	31,75 - 32,50	42	43	33
5,85 - 6,60	8	9	-	32,50 - 33,30	43	44	34
6,60 - 7,30	9	10	-	33,30 - 34,05	44	45	35
7,30 - 8,15	10	11	-	34,05 - 34,80	45	46	36
8,15 - 8,90	11	12	-	34,80 - 35,55	46	47	37
8,90 - 9,65	12	13	3	35,55 - 36,30	47	48	38
9,65 - 10,40	13	14	4	36,30 - 37,10	48	49	39
10,40 - 11,20	14	15	5	37,10 - 37,85	49	50	40
11,20 - 11,95	15	16	6	37,85 - 38,60	50	51	41
11,95 - 12,70	16	17	7	38,60 - 39,35	51	52	42
12,70 - 13,50	17	18	8	39,35 - 40,10	52	53	43
13,50 - 14,20	18	19	9	40,10 - 40,90	53	54	44
14,20 - 15,00	19	20	10	40,90 - 41,65	54	55	45
15,00 - 15,75	20	21	11	41,65 - 42,40	55	56	46
15,75 - 16,50	21	22	12	42,40 - 43,15	56	57	47
16,50 - 17,30	22	23	13	43,15 - 43,90	57	58	48
17,30 - 18,00	23	24	14	43,90 - 44,70	58	59	49
18,00 - 18,80	24	25	15	44,70 - 45,45	59	60	50
18,80 - 19,55	25	26	16	45,45 - 46,20	60	-	51
19,55 - 20,30	26	27	17	46,20 - 46,95	-	-	52
20,30 - 21,10	27	28	18	46,95 - 47,70	-	-	53
21,10 - 21,85	28	29	19	47,70 - 48,50	-	-	54
21,85 - 22,60	29	30	20	48,50 - 49,25	-	-	55
22,60 - 23,40	30	31	21	49,25 - 50,00	-	-	56
23,40 - 24,15	31	32	22	50,00 - 50,75	-	-	57
24,15 - 24,90	32	33	23	50,75 - 51,50	-	-	58
24,90 - 25,65	33	34	24	51,50 - 52,30	-	-	59
25,65 - 26,40	34	35	25	52,30 - 53,05	-	-	60
26,40 - 27,20	35	36	26	53,05 - 53,80	-	-	-

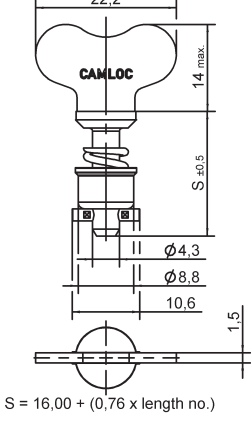
Other Lengths on request.

Style	Dimensions	Materials / Finish	°C	Part No.
<p>Slotted Recess Head</p> 	 <p>S = 16,00 + (0,76 x length no.)</p>	<p>Steel / zinc-plated, CrVI-free, clear passivation</p> <p>Stainless steel ¹⁾</p>	<p>120</p> <p>200</p>	<p>D4002-*AGV</p> <p>D4002-*BP</p>
<p>Cross Recess Head</p> 	 <p>S = 16,00 + (0,76 x length no.)</p>	<p>Steel / zinc-plated CrVI-free, clear passivation</p> <p>Stainless steel ¹⁾</p>	<p>120</p> <p>200</p>	<p>D40S5-*AGV</p> <p>D40S5-*BP</p>
<p>Fixed Wing Handle</p> 	 <p>S = 16,00 + (0,76 x length no.)</p>	<p>Steel / zinc-plated, CrVI-free, clear passivation</p> <p>Stainless steel ¹⁾</p>	<p>120</p> <p>200</p>	<p>D4002-*WAGV</p> <p>D4002-*WBP</p>

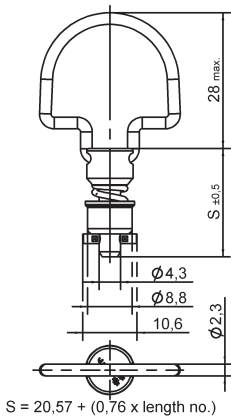

* Length no. from Table, page G-2 and G-3

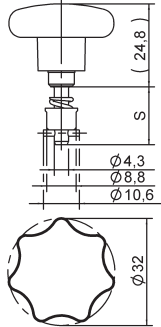
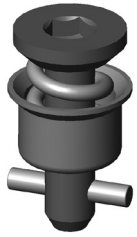
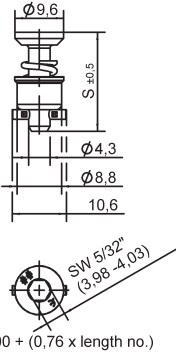
¹⁾ Max. tensile strength 3.300 N, working load 2.200 N

Style	Dimensions	Materials / Finish	°C	Part No.
Folding Bail Handle 180° 	 <p>$S = 20,57 + (0,76 \times \text{length no.})$</p>	Steel / zinc-plated, CrVI-free, clear passivation	120	D40S47-*AGV
Star Form Handle Plastic 	 <p>$S = 16,00 + (0,76 \times \text{length no.})$</p>	Steel / zinc-plated, CrVI-free, clear passivation	-40 up to +60	D40E22-*AGV
Hex Recess Head 	 <p>$S = 16,00 + (0,76 \times \text{length no.})$</p>	Steel / zinc-plated, CrVI-free, clear passivation Stainless steel ¹⁾	120 200	D40E28- *AGV D40E28-*BP

* Length no. from Table, page G-2 and G-3

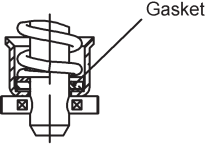
¹⁾ Max. tensile strenght 3.300 N, working load 2.200 N

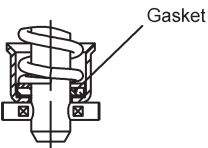
Style	Dimensions	Materials / Finish	°C	Part No.
Sealed Slotted Recess Head 	 Additional required gasket see page G-4	Steel / zinc-plated, CrVI-free, clear passivation Gasket: Vulkollan®* Available in Stud Length no. 4 and above	-15 to +80	D4002I-*AGV
		Stainless steel ¹⁾	200	D4002I-*BP
Sealed Cross Recess Head 	 Additional required gasket see page G-4	Steel / zinc-plated, CrVI-free, clear passivation Gasket: Vulkollan®* Available in Stud Length no. 4 and above	-15 to +80	D40S5I-*AGV
		Stainless steel ¹⁾	200	D40S5I-*BP

* Vulkollan® is a registered brand of Bayer AG.



¹⁾ Max. tensile strenght 3.300 N, working load 2.200 N

Click here: [D4002 installation – including new Camloc Mounting Tool 4002T02](#) (Youtubelink)

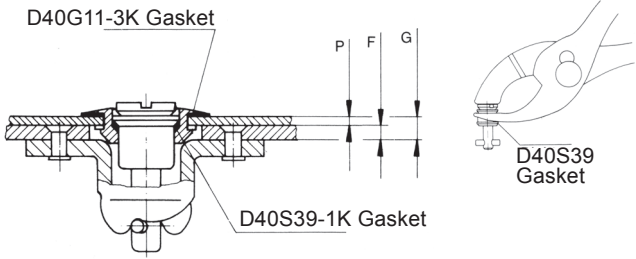
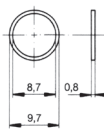
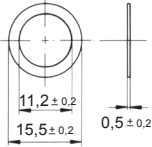



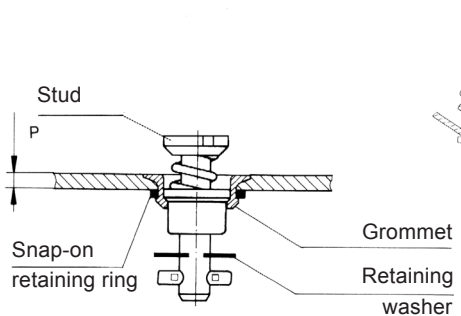
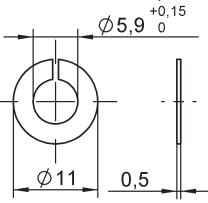
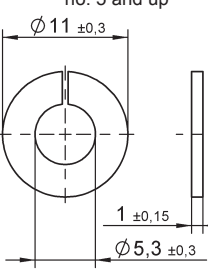
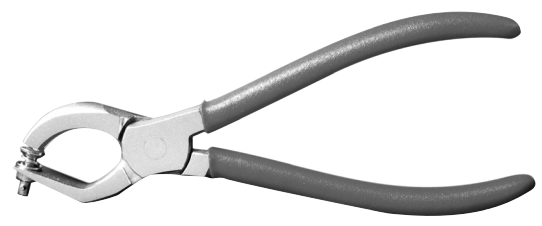

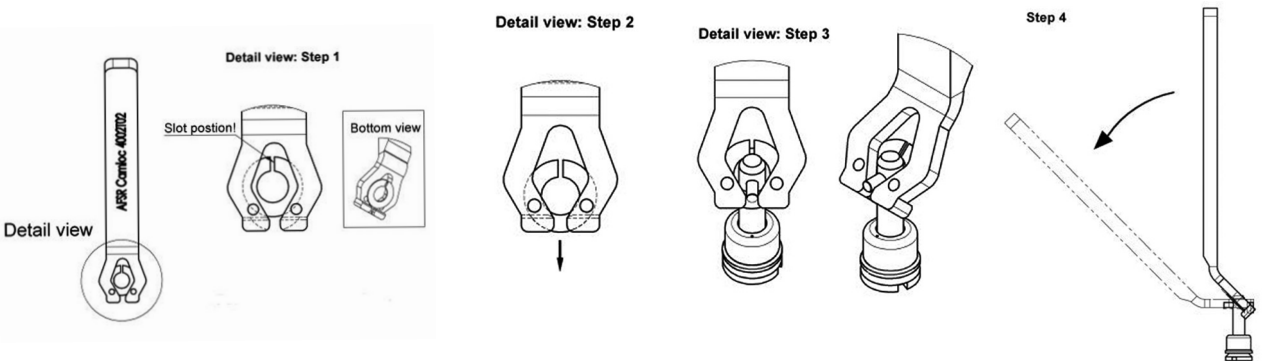



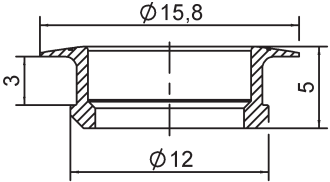

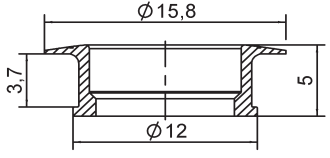

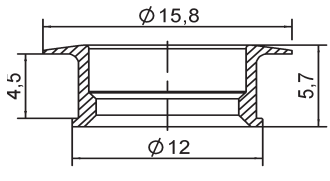

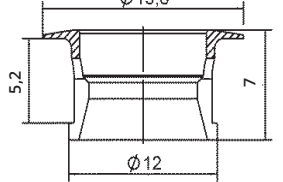

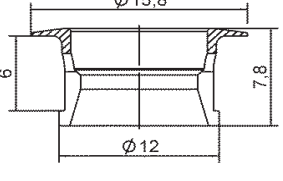
Installation Dimensions	Accessories	Materials / Finish	Part No.
<p>Gasket to be ordered in addition to the sealed stud assembly</p> 	Gasket 	Plastic / (PA6)	D40S39-1K
	Gasket 	EPDM black	D40G11-3K

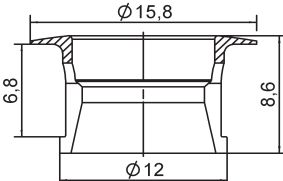

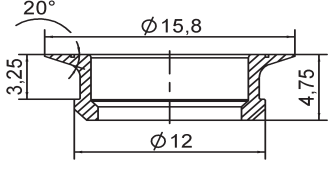

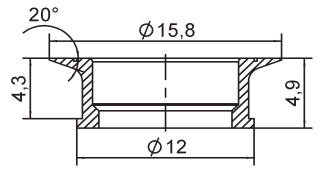
* Length no. from Table, page G-2 and G-3



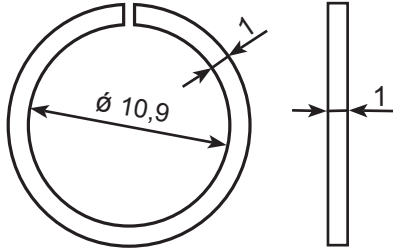
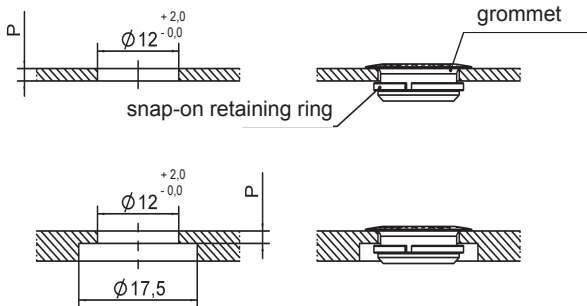
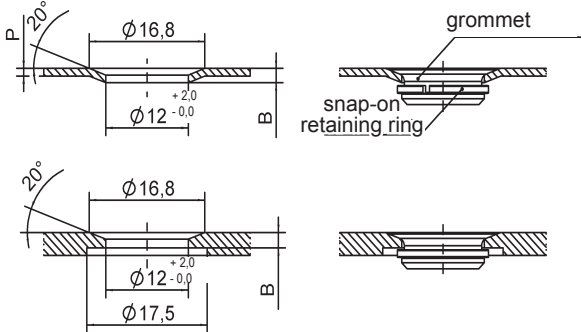
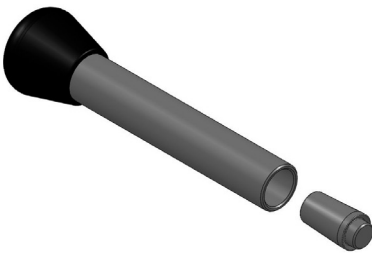
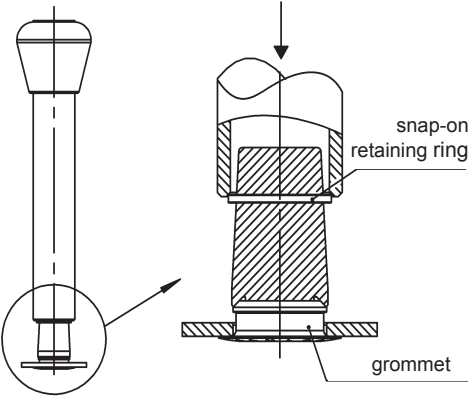

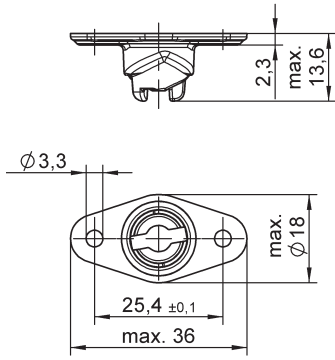
Installation Dimensions	Accessories	Materials / Finish	Part No.
 <p>Stud P Snap-on retaining ring Grommet Retaining washer</p> <p>4P3-1 installation pliers, see below</p>	<p>retaining ring loose on stud use for stud length no. 5 and up</p>  <p>retaining ring loose on stud use for stud length no. 5 and up</p> 	<p>Stainless steel</p> <p>Plastic</p>	<p>4002-SW-SS</p> <p>50W204-01K</p>
	<p>Stud installation pliers</p>		<p>4P3-1</p>
	<p>Mounting tool for retaining washers*</p>		<p>4002T02-1BP</p>
<p style="text-align: center;">installation of 4002-SW-SS</p>  <p>Detail view: Step 1 Detail view: Step 2 Detail view: Step 3 Step 4</p>			

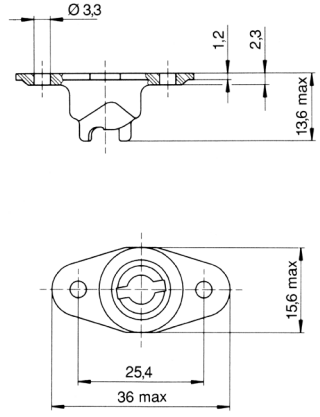

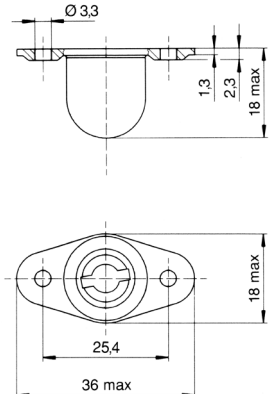
* Mounting tool 4002T02 is only for retaining washers of (D)4002 Series.

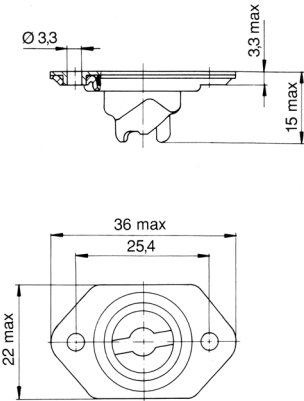
Style	Dimensions	Materials/ Finish	°C	Part no.
Plus Flush Mounting For Panel Thickness up to 1,65 		Steel/ zinc-plated CrVI-free, clear passivation stainless steel	120 200	D4002-N-AGV 4002-NS
Plus Flush Mounting For Panel Thickness from 1,65 to 2,40 		Steel/ zinc-plated CrVI-free, clear passivation stainless steel	120 200	D4002-O-AGV 4002-OS
Plus Flush Mounting For Panel Thickness from 2,40 to 3,20 		Steel/ zinc-plated CrVI-free, clear passivation stainless steel	120 200	D4002-P-AGV D4002-P-BP
Plus Flush Mounting For Panel Thickness from 3,20 to 3,95 		Steel/ zinc-plated CrVI-free, clear passivation stainless steel	120 200	D4002-R-AGV D4002-R-BP
Plus Flush Mounting For Panel Thickness from 3,95 to 4,75 		Steel/ zinc-plated CrVI-free, clear passivation stainless steel	120 200	D4002-S-AGV D4002-S-BP
Plus Flush Mounting For Panel Thickness from 4,80 to 5,60 		Steel/ zinc-plated CrVI-free, clear passivation stainless steel	120 200	D4002-T-AGV D4002-T-BP
Flush Mounting For Panel Thickness up to 1,88 		Steel/ zinc-plated CrVI-free, clear passivation stainless steel	120 200	D4002-G-AGV 4002-GS
Flush Mounting For Panel Thickness from 1,88 to 2,97 		Steel/ zinc-plated CrVI-free, clear passivation stainless steel	120 200	D4002-H-AGV 4002-HS

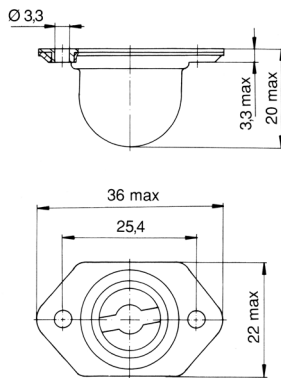
Style	Dimensions	Materials/ Finish	Part no.
		Steel/ zinc-plated, CrVI-free, clear passivation stainless steel stainless steel/ non-magnetic	R4G-3 V40G26-1BP V40G26-1N
		Grommet plus Flush Part no.	P_{max}
		D4002-N-AGV / 4002-NS D4002-O-AGV / 4002-OS D4002-P-AGV / D4002-P-BP D4002-T-AGV / D4002-T-BP	1,65 2,40 3,20 5,60
		Grommet Flush Part no.	P_{max} B_{max}
		D4002-G-AGV / 4002-GS D4002-H-AGV / 4002-HS	1,65 1,88 2,18 2,97
			T26

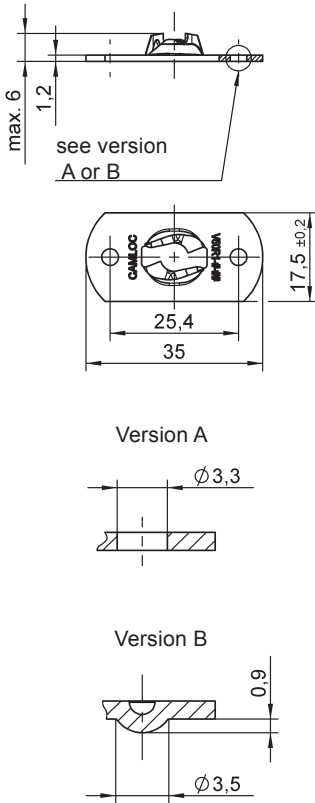
Style	Dimensions	Materials / Finish	°C	Part No.
<p>Type 1 Cast</p> 		<p>Hard bronze / zinc-plated, CrVI-free, clear passivation</p> <p>Stainless steel</p>	<p>120</p> <p>200</p>	<p>D214-16FGV</p> <p>214-16S</p>
<p>Type 1 Cast Narrow Width</p> 		<p>Hard bronze / zinc-plated, CrVI-free, clear passivation</p>	<p>120</p>	<p>D214-16NFGV</p>
<p>Type 1 Cast Encapsulated</p> 		<p>Hard bronze / zinc-plated, CrVI-free, clear passivation</p> <p>Capsule: Brass / zinc-plated, CrVI-free, clear passivation</p>	<p>150</p>	<p>D40R12-1FGV</p>

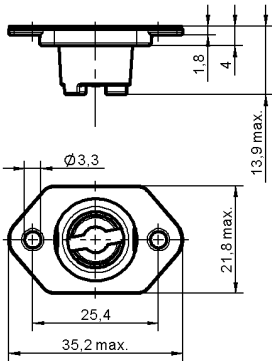
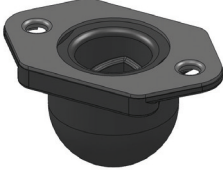
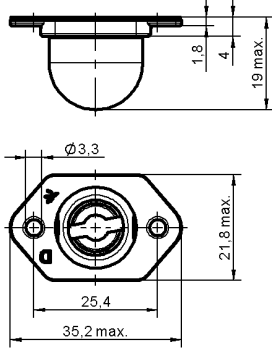
Style	Dimensions	Materials / Finish	°C	Part No.
<p>Type 2 Float up to 0,75 mm (Cast Receptacle)</p> 		<p>Hard bronze / zinc-plated, CrVI-free, clear passivation</p> <p>Cage: Steel / zinc-plated, CrVI-free, clear passivation</p> <p>Stainless steel</p>	<p>120</p> <p>200</p>	<p>D244-16-FGV</p> <p>244-16S</p>
<p>Type 2 Float up to 0,75 mm Encapsulated</p> 		<p>Hard bronze / zinc-plated, CrVI-free, clear passivation</p> <p>Capsule: Steel / zinc-plated, CrVI-free, clear passivation</p> <p>Stainless steel</p>	<p>120</p> <p>200</p>	<p>D244-16C-FGV</p> <p>244-16SC</p>
<p>Type 3 Flat Rivet / Screw or Weld Mounting</p> 	 <p>Version A</p> <p>Version B</p>	<p>Rivet / Screw Mounting</p> <p>Steel / zinc-plated, CrVI-free, clear passivation</p> <p>Stainless steel</p> <p>Welding (B) Steel / zinc-plated</p> <p>Steel/oil-coated</p>	<p>120</p> <p>200</p> <p>-</p> <p>-</p>	<p>V50R1-1-1AGV</p> <p>V50R1-1-1BP</p> <p>V50R1-1-2AZ</p> <p>V50R1-1-2AR</p>

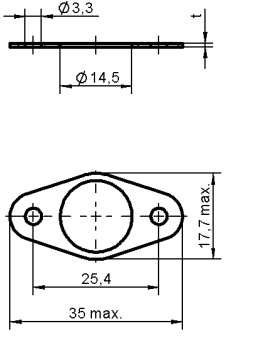
Style	Dimensions	Materials / Finish	°C	Part No.
Type 2 Float up to 0,75 mm (Torlon) 		Torlon, base plate: Steel / zinc-plated, CrVI-free, clear passivation	120	V244-16T1
		Torlon, base plate: Stainless steel	120	V244-16TS1
Type 2 Float up to 0,75 mm (Torlon) Encapsulated 		Torlon, base plate: Steel / zinc-plated, CrVI-free, clear passivation	120	V244-16T1C
		Torlon, base plate: Stainless steel	120	V244-16TS1C
Shim 		Aluminum t=0,8mm	175	D40W02-1DR
		Aluminum t=1,5mm to be used with: D214-16FGV 214-16 S D214-16 NFGV D40R12-1FGV	175	D40W02-2DR

Installation Dimensions

Types 1, 2 and 3
Receptacle Hole Pattern

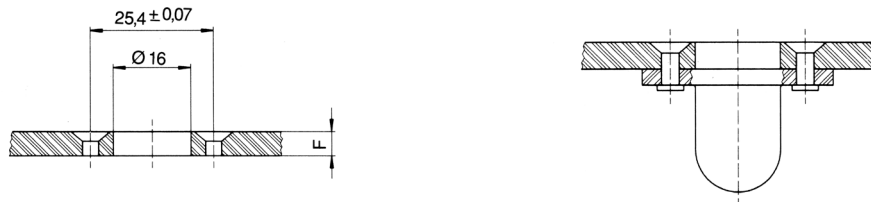

Features

Max. tensile strength 10.000 N, working load 7.000 N.

High tensile strength and preload.

Typical applications:

Commercial vehicles, coaches, agricultural machinery, chemical engineering, heating systems etc.

1. Select stud assembly and receptacle, pages H-2, H-3 and H-5.
2. Sealed: Also select rubber gasket and buffer plate, page H-4.
3. Select retaining washer, page H-4.
4. Select stud length number from total thickness G using the formula and table below (e.g. 991S01-*AGV).

Determining the stud length number when using:

Rivet, Screw and Weld Mounting Receptacle

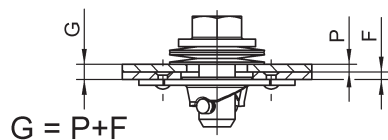

Clip-On Receptacle

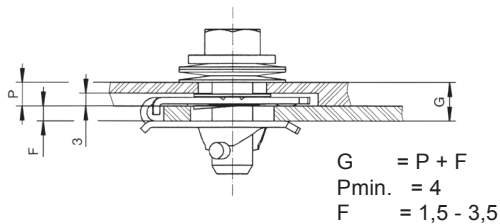

Sealed Stud Assemblies

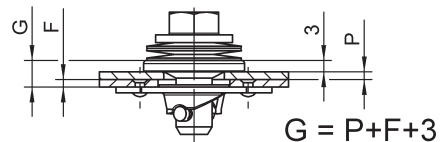

Click here:

[Quarter Turn Installation \(991F Series\)](#)



(Youtubelink)



Stud Length Table



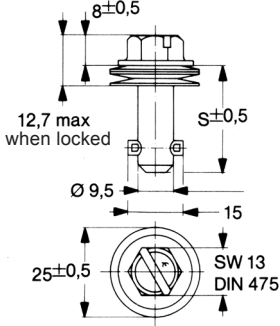
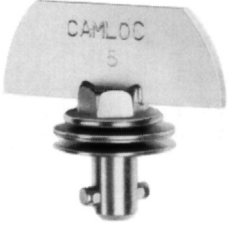
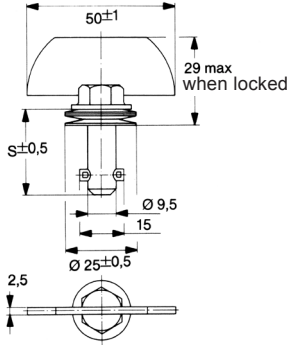
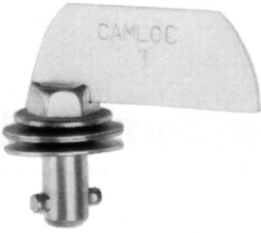
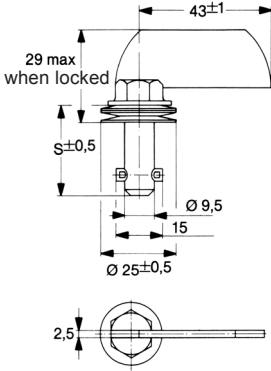

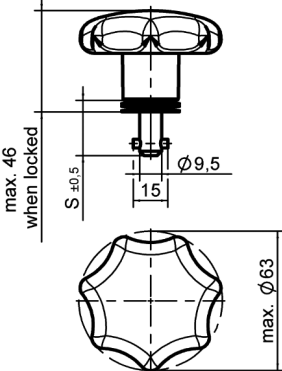
Total Thickness G	Stud Length No.	Total Thickness G	Stud Length No.	Total Thickness G	Stud Length No.
0,90 - 1,65	1	13,85 - 14,60	18	26,80 - 27,55	35
1,65 - 2,40	2	14,60 - 15,35	19	27,55 - 28,30	36
2,40 - 3,15	3	15,35 - 16,15	20	28,30 - 29,10	37
3,15 - 3,95	4	16,15 - 16,90	21	29,10 - 29,85	38
3,95 - 4,70	5	16,90 - 17,65	22	29,85 - 30,60	39
4,70 - 5,45	6	17,65 - 18,40	23	30,60 - 31,35	40
5,45 - 6,20	7	18,40 - 19,20	24	31,35 - 32,15	41
6,20 - 7,00	8	19,20 - 19,95	25	32,15 - 32,90	42
7,00 - 7,75	9	19,95 - 20,70	26	32,90 - 33,65	43
7,75 - 8,50	10	20,70 - 21,45	27	33,65 - 34,40	44
8,50 - 9,25	11	21,45 - 22,25	28	34,40 - 35,20	45
9,25 - 10,05	12	22,25 - 23,00	29	35,20 - 35,95	46
10,05 - 10,80	13	23,00 - 23,75	30	35,95 - 36,70	47
10,80 - 11,55	14	23,75 - 24,50	31	36,70 - 37,45	48
11,55 - 12,30	15	24,50 - 25,25	32	37,45 - 38,25	49
12,30 - 13,10	16	25,25 - 26,05	33	38,25 - 39,00	50
13,10 - 13,85	17	26,05 - 26,80	34		

Other lengths on request.

Style	Dimensions	Materials / Finish	°C	Part No.
<p>Hex Head Slotted Recess</p> 	 <p>$8 \pm 0,5$ 12,7 max when locked $s \pm 0,5$ $\varnothing 9,5$ 15 $25 \pm 0,5$ SW 13 DIN 475</p> <p>$S = 16,26 + (0,76 \times \text{length no.})$</p>	<p>Steel / zinc-plated, CrVI-free, clear passivation</p> <p>Stainless steel ¹⁾</p>	<p>120</p> <p>200</p>	<p>991S01- *-1AGV</p> <p>991S01- *-1BP</p>
<p>Fixed Wing Handle</p> 	 <p>50 ± 1 29 max when locked $s \pm 0,5$ $\varnothing 9,5$ 15 $\varnothing 25 \pm 0,5$ 2,5</p> <p>$S = 16,26 + (0,76 \times \text{length no.})$</p>	<p>Steel / zinc-plated, CrVI-free, clear passivation</p> <p>Stainless steel ¹⁾</p>	<p>120</p> <p>200</p>	<p>991S02- *-1AGV</p> <p>991S02- *-1BP</p>
<p>Offset Fixed Wing Handle</p> 	 <p>43 ± 1 29 max when locked $s \pm 0,5$ $\varnothing 9,5$ 15 $\varnothing 25 \pm 0,5$ 2,5</p> <p>$S = 16,26 + (0,76 \times \text{length no.})$</p>	<p>Steel / zinc-plated, CrVI-free, clear passivation</p> <p>Stainless steel ¹⁾</p>	<p>120</p> <p>200</p>	<p>991S03- *-1AGV</p> <p>991S03- *-1BP</p>
<p>Star Form Handle Plastic</p> 	 <p>max. 46 when locked $s \pm 0,5$ $\varnothing 9,5$ 15 max. $\varnothing 63$</p> <p>$S = 16,26 + (0,76 \times \text{length no.})$</p>	<p>Steel / zinc-plated, CrVI-free, clear passivation</p>	<p>-40 up to +60</p>	<p>991S04- *-1AGV</p>

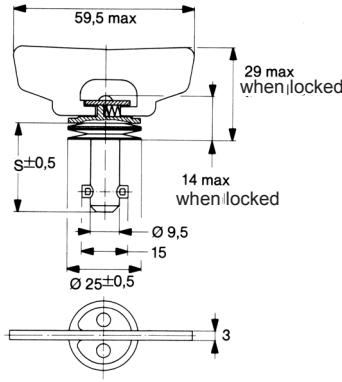
* Length no. from Table, see page H-1.

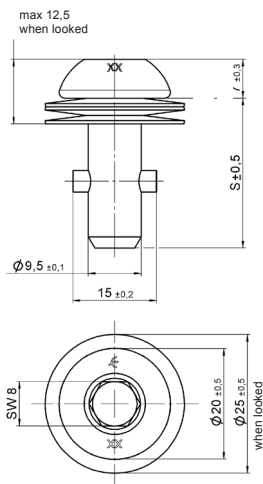
¹⁾ Max. tensile strength 7.000 N, working load 4.500 N.

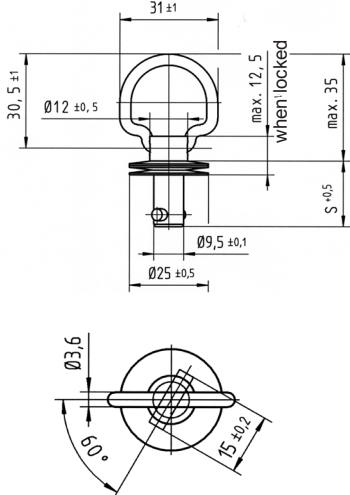

Style	Dimensions	Materials / Finish	°C	Part No.
Folding Wing Handle 180° 	 <p>S = 16,26 + (0,76 x length no.)</p>	Steel / zinc-plated, CrVI-free, clear passivation	120	991S05- *-1AGV
Hex Recess Head 		Steel / zinc-plated, CrVI-free, clear passivation	120	991S30-*AGV
Folding Bail Handle 180° 	 <p>S = 15,03 + (0,76 X length no.)</p>	Steel / zinc-plated, CrVI-free, clear passivation	120	991S2991-*AGV

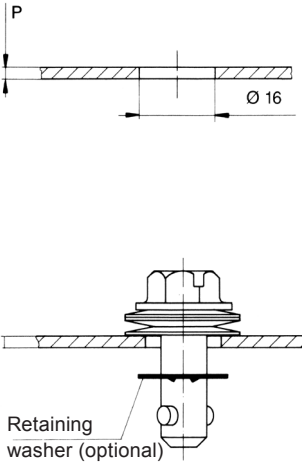
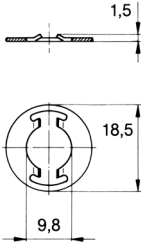
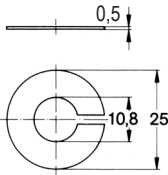
* Length no. from Table, see page H-1.

Installation Dimensions	Accessories	Material / Finish	Part No.
	<p>Retaining washer</p>  <p>Slotted retaining washer</p> 	<p>Stainless steel</p> <p>Stainless steel</p>	<p>991W04-1BP</p> <p>991W02-1BP</p>

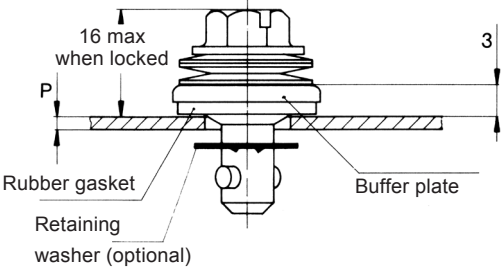
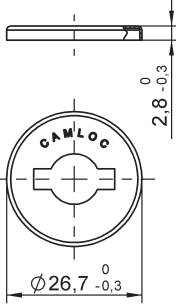
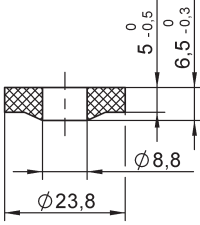
Sealed Stud Assemblies

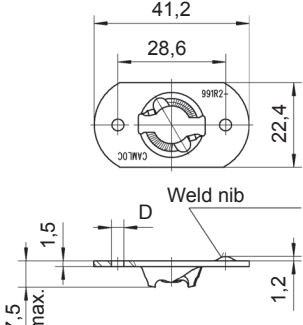
Installation Dimensions	Accessories	Material / Finish	Part No.
	<p>Buffer plate</p>  <p>Rubber gasket</p> 	<p>Stainless steel</p> <p>SBR/NBR or alternative SBR/NR black (100°C max.)</p>	<p>991W03-1BP</p> <p>991S17-1K</p>

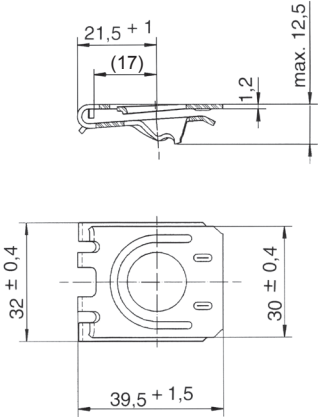
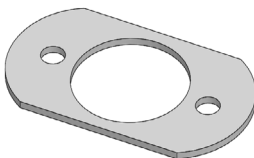
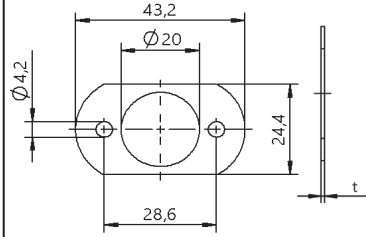
Style	Dimensions	Materials / Finish	Mounting Ø	°C	Part No.
Rivet / Screw Mounting 		Rivet / Screw Mounting Steel / zinc-plated, CrVI-free, clear passivation	3,3	120	991R2-1AGV
		Steel / zinc-plated, CrVI-free, clear passivation	4,1	120	991R2-3AGV
		Stainless steel	3,3	200	991R2-1BP
		Stainless steel	4,1	200	991R2-3BP
		Welding Steel / zinc-plated	-	-	991R2-2AZ
		Steel / oil coated	-	-	991R2-2AR
Clip-On 		Steel / zinc-plated, zinc flake coated Frame thickness F= 1,5mm - 3,5mm		150	991R6-1AK7
Distance Plate* 		POM schwarz/ t=0,8	4,2	100	991W120-08K
		POM schwarz/ t=1,0	4,2	100	991W120-10K
		POM schwarz/ t=1,5	4,2	100	991W120-15K
		POM schwarz/ t=2,0	4,2	100	991W120-20K

* If you have slightly different clamping thicknesses in an application, it is possible to compensate them with our distance plates, which are fixed under the retaining cam. This makes it possible to use only one stud length.

Receptacle Installation Instructions

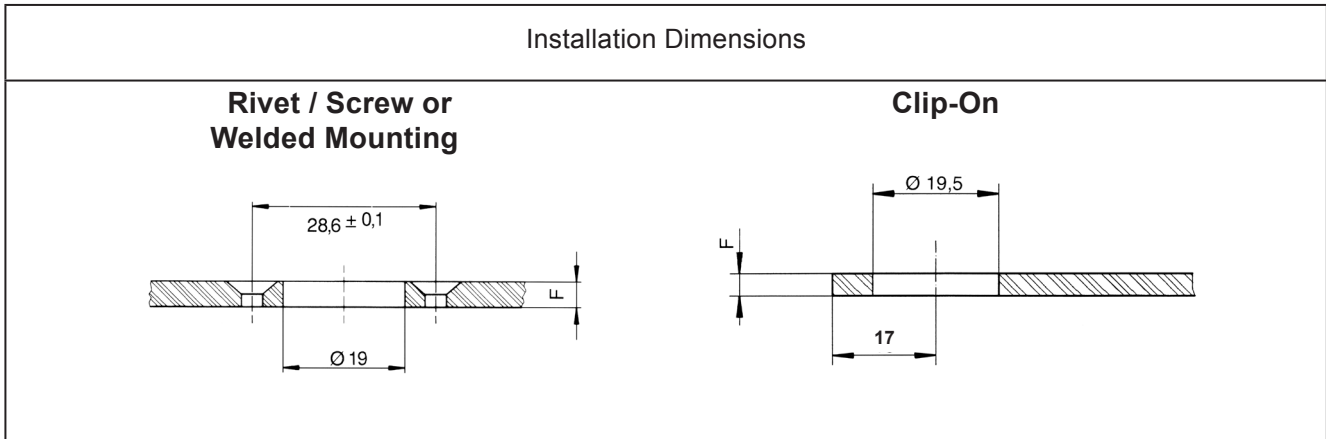

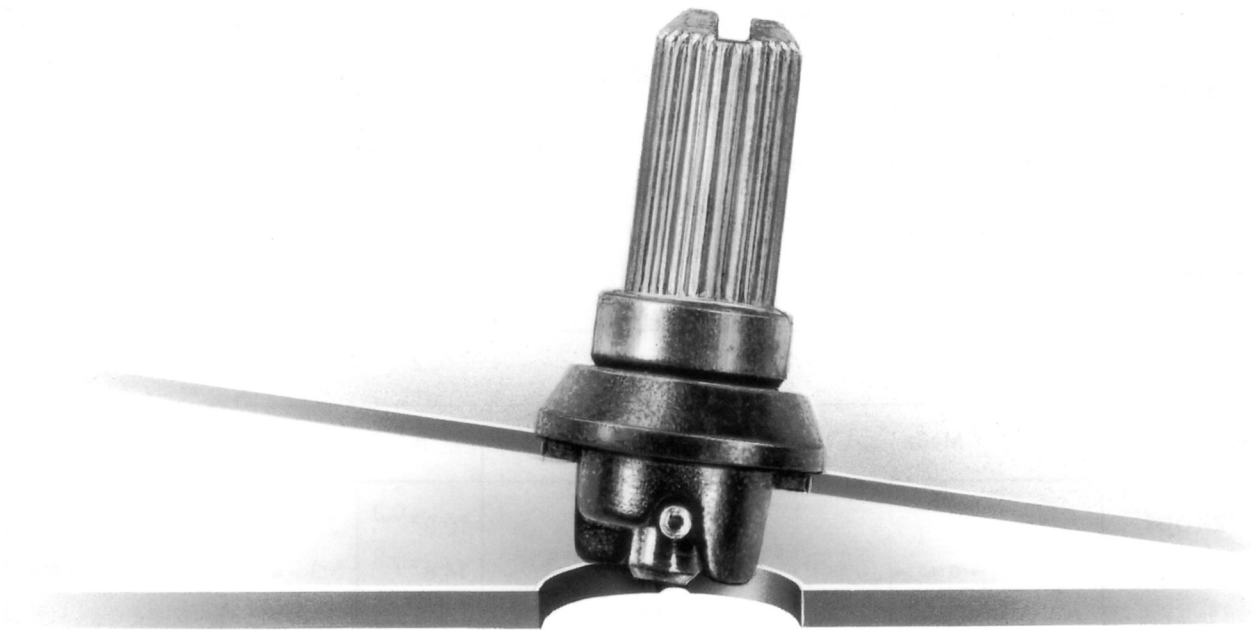

Features

- Max. tensile strength 300 N, working load 200 N.
- Same hole shape for panel and frame.
- Available in slotted recess or knurled head styles .
- Fastener position indication by stud slot.
- Stud assembly captive in the panel.
- Vibration resistant.
- Grip ranges from 2,0 mm to 4,6 mm.
- Lock and unlock by a quarter turn.
- Typical applications are in electro-mechanical and electronic equipment.
- Quick installation without tools.

Part no. example

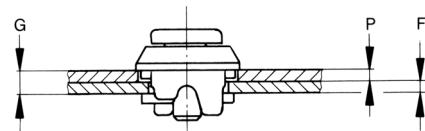
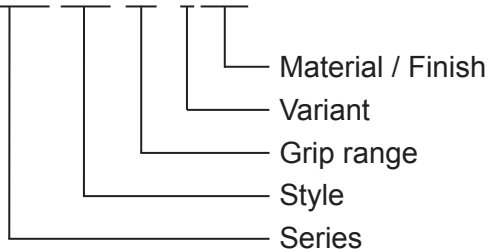

Knurled head for 3,3 mm to 4,6 mm grip range.

V936 S11 -4 -1 AA

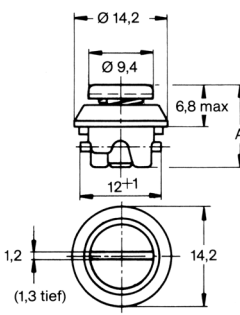

$$G = P + F$$

$$P_{min} = 1,2 \text{ mm}$$

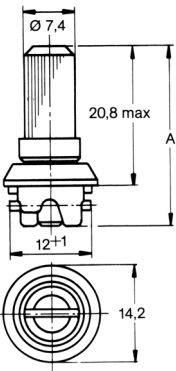
Style	Dimensions	Materials / Finish	A	Grip Range G	°C	Part No.
Slotted Recess Head 		Stud, spiral pin: Steel / zinc-plated, CrVI-free, clear chromate Compression spring: Stainless steel Casing: Zinc die casting / zinc-plated, CrVI-free, clear chromate	12,3 ^{±0,3}	2,0 - 3,2	100	V936S05-3-1AA
			14,8 ^{±0,3}	3,3 - 4,6	100	V936S05-4-1AA
Knurled Head 		Stud, Casing: Zinc die casting / zinc-plated, CrVI-free, clear chromate Compression spring: Stainless steel Spiral pin: Steel / zinc-plated, CrVI-free, clear chromate	26,4 ^{±0,3}	2,0 - 3,2	100	V936S11-3-1AA
			28,9 ^{±0,3}	3,3 - 4,6	100	V936S11-4-1AA

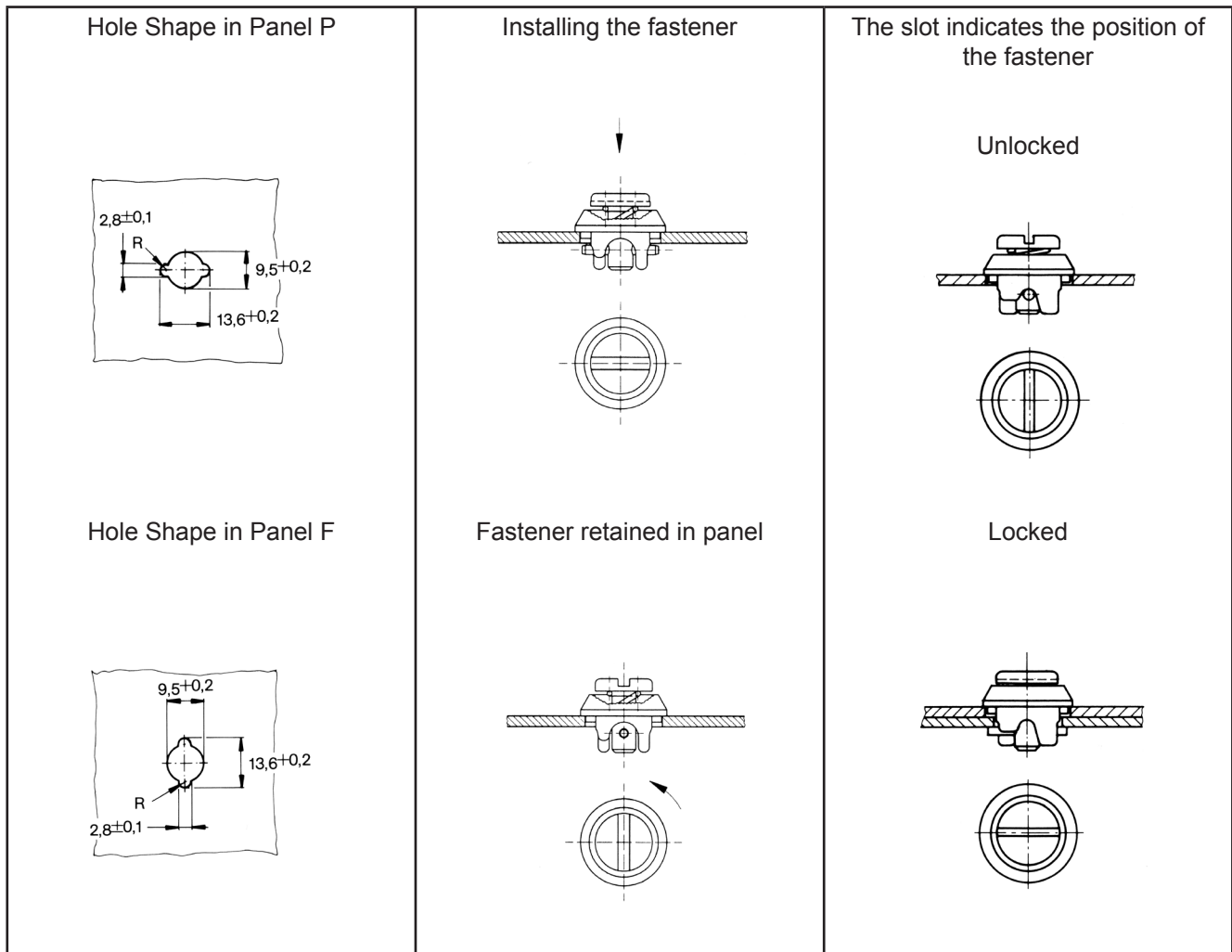



Features

This fastener fastens panels in electrical switch cabinets (e.g. 19"-equipment) to modular bars.

Selection Instructions

The dimensions of the front panel and the modular bar as well as the colour determine the final design of the fastener.

To enable us to offer you the custom-tailored fastener, we need your drawings with the dimensions and tolerances of:

1. the front panel
2. the shape of the modular bar
3. the colour, if necessary

In addition, please send us samples of your modular bar and front panel.



Part no. example

One-piece fastener

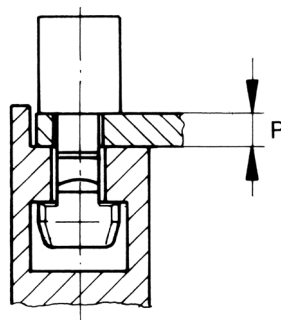
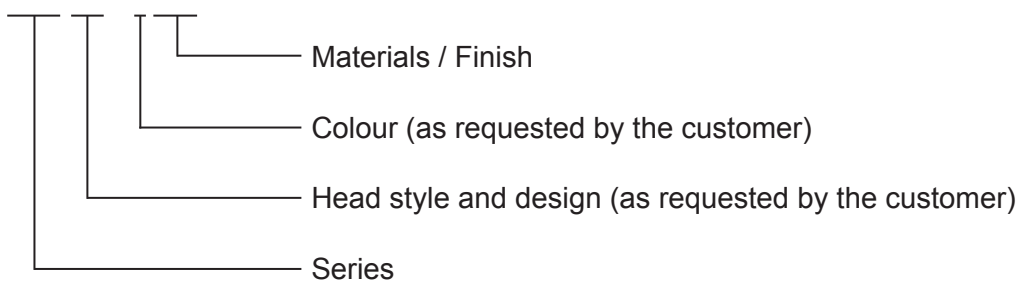
713 S* - * AE

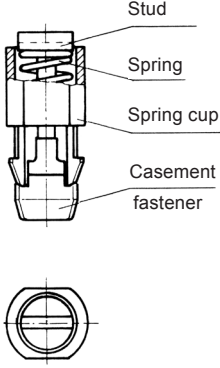

Due to the various front panel thickness, hole shapes and modular bar shapes, it is not possible to offer one standard design. We will individually issue the final part number only after determining the front panel and modular bar dimensions and the colour.

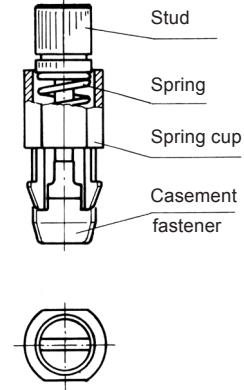
Style	Dimensions	Materials / Finish	°C	Part No.
<p>Slotted Recess Head</p> 		<p>Spring cup: Plastic (POM) Stud: Steel / nickel-plated Spring: Steel / zinc-plated, CrVI-free, clear chromate Casement fastener: Zinc die casting / zinc-plated, CrVI-free, clear chromate</p>	-25 up to +90	713S* - *AE
<p>Knurled Head</p> 		<p>Spring cup: Plastic (POM) Stud: Steel / nickel-plated Spring: Steel / zinc-plated, CrVI-free, clear chromate Casement fastener: Zinc die casting / zinc-plated, CrVI-free, clear chromate</p>	-25 up to +90	713S* - *AE

* Design and colour as requested by the customer.

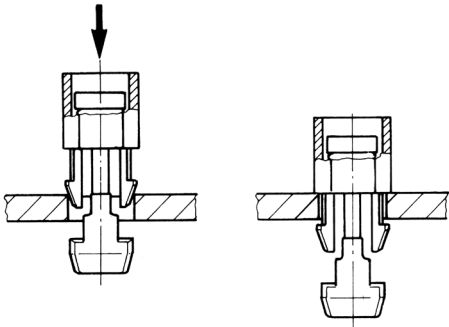
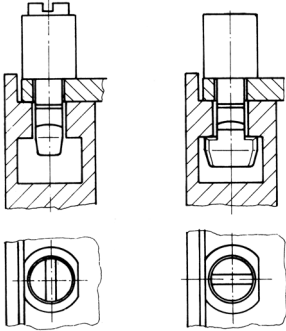
Dimensions	Fastener Position
<p>Installing the Fastener</p> 	<p>Unlocked Locked</p>  <p>To lock push stud and turn 90°C.</p> <p>The slot indicates the position of the fastener.</p>
<p>1. Insert fastener with spring cup into hole. 2. Push stud until snap-in hooks lock in.</p>	



Features

Max. tensile strength 1.330 N, working load 930 N.
Quick opening and closing by a push of the finger.
Easy installation with single hole mounting.

Selection Instructions

1. Select stud assembly, page K-2 or K-3 and receptacle, page K-4.
2. Select retaining washer, page K-2 and retaining hexnut, page K-3, if necessary.
3. Select stud length number from Panel thickness P or Panel distance G using the table below.

Push Button

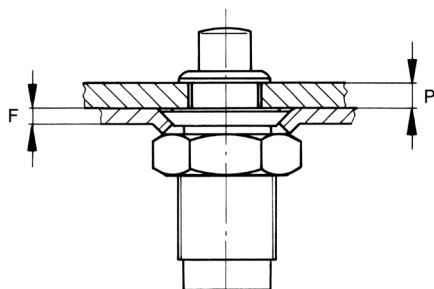

Push Panel

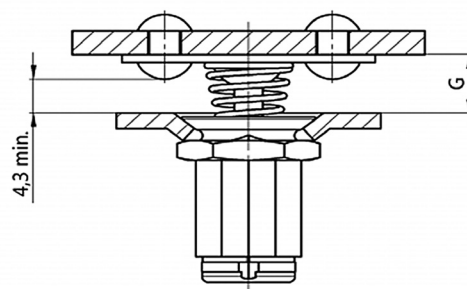

Stud Length Table

Panel Thickness P	Stud Length No.
0,7 - 2,3	1
2,3 - 3,8	3
3,8 - 5,3	5
5,3 - 6,9	7
6,9 - 8,4	9
8,4 - 9,9	11
9,9 - 11,4	13
11,4 - 13,0	15

Other lengths on request.

Stud Length Table

Panel Distance G	Stud Length No.
6,1 - 6,9	8
6,9 - 7,6	9
7,6 - 8,4	10
8,4 - 9,1	11
9,1 - 9,9	12
9,9 - 10,7	13
10,7 - 11,4	14
11,4 - 12,2	15

Other lengths on request.

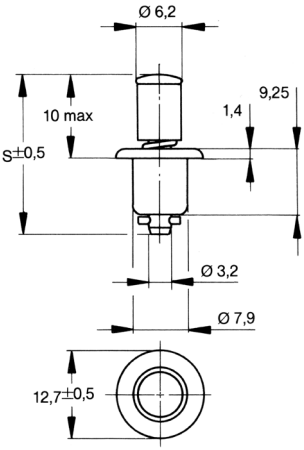
Style	Dimensions	Materials / Finish	°C	Part No.
<p>Push Button</p> 	 <p>S=22,4 + (0,76 x length no.)</p>	Steel / nickel-plated	120	15S1- *-1AD
		Steel / zinc-plated CrVI-free, clear passivation	120	15S1- *-1AJ

* Length no. from Table „Push Button“, see page K-1.

Other lengths and surfaces can be ordered upon request.

Stud Installation Instructions

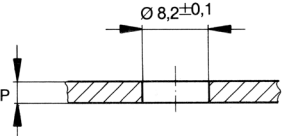
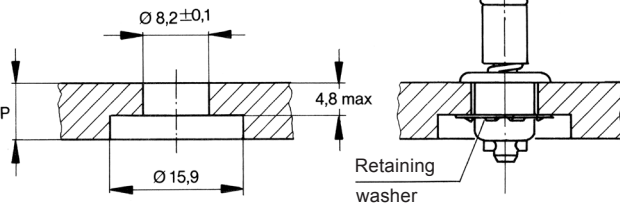
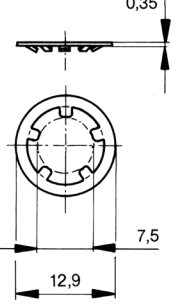
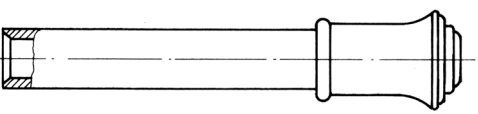
Installation Dimensions	Accessories	Materials / Finish	Part No.
<p>Panel thickness up to 4,8</p>  <p>Panel thickness from 4,8 + up</p> 	<p>Retaining washer</p> 	Stainless steel	15S11-1CJ
	<p>Installation Tool for 15S11-1CJ retaining washer</p>		T107-1

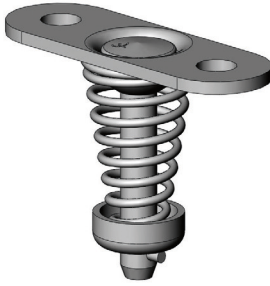
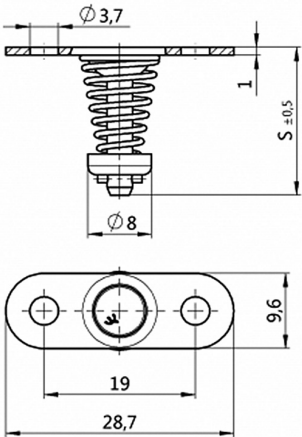
Style	Dimensions	Materials / Finish	°C	Part No.
<p>Push Panel</p> 	 <p>$S=22,4 + (0,76 \times \text{length no.})$</p>	<p>Steel / zinc-plated CrVI-free, clear passivation</p>	120	V15S20- *-1AGV

* Length no. from Table „Push Panel“, see page K-1.

Other lengths and surfaces can be ordered upon request.

Stud Installation Instructions

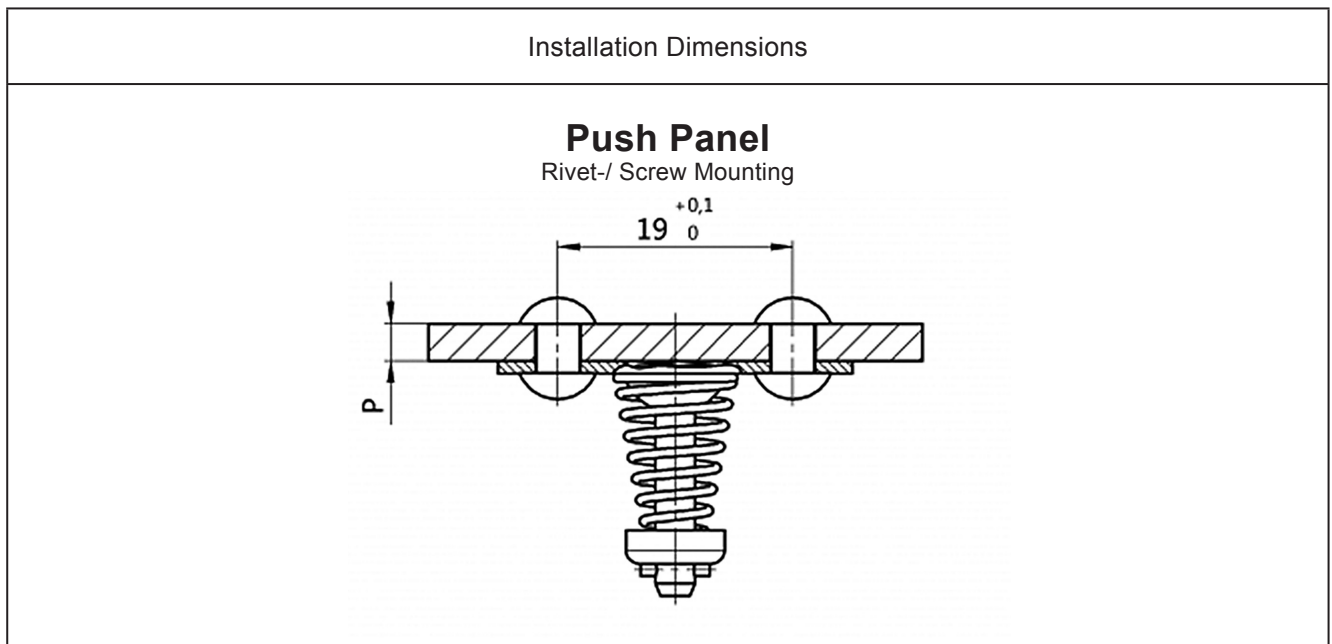

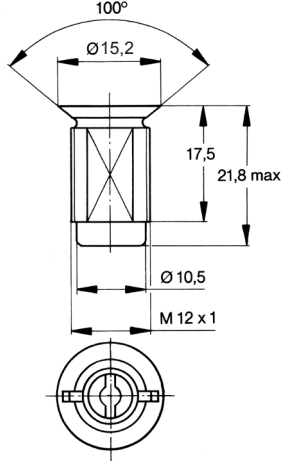
Style	Dimensions	Materials / Finish	°C	Part No.
		Zinc die casting / zinc-plated CrVI-free, clear passivation	120	V15R13-1-1AB

Receptacle Installation Instructions

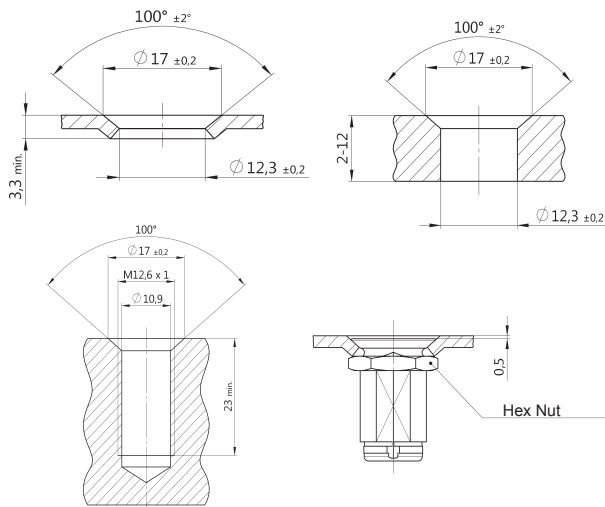
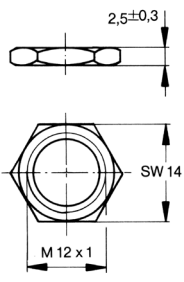
Installation Dimensions	Accessories	Materials / Finish	Part No.
	Hex Nut  Recommended torque for the Hex Nut: 2.3Nm to 3.0Nm	Steel / zinc-plated, CrVI-free, clear passivation	V15R14-1-1AB





Features

Max. tensile strength 700 N, working load 600 N.

Easy and economic clip-in installation for stud and receptacle.

Also suitable for automatic installation.

1/4 turn to open - close by a push of the finger.

Due to their small size they are particularly suited for use in electrical engineering and electronics.

Selection Instructions

1. Select stud assembly according to panel thickness P, page L-2 and spring clip according to frame thickness F, page L-3.
2. Select stud length number from panel thickness G using the table below, insert into stud part number * (e.g. 715S12-* -1BP).

Part no. example

Stud, slotted recess head

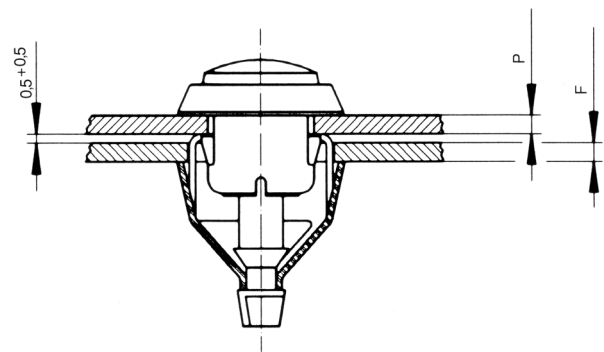
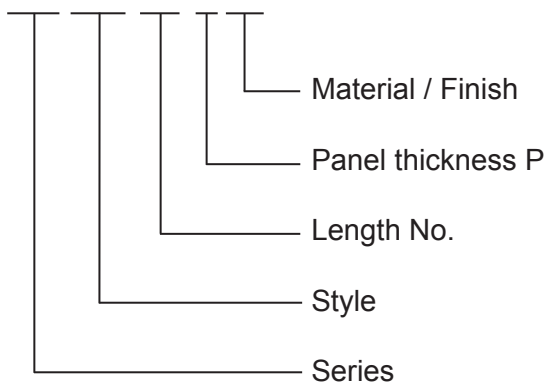

715 S12 -07 -3BP



Stud Length Table

Panel Thickness P	Slotted Recess Head Stud Length No.	Knurled Head Stud Length No.	Panel Thickness P	Slotted Recess Head Stud Length No.	Knurled Head Stud Length No.
0,50 - 1,25	5	5	6,50 - 7,25	13	-
1,25 - 2,00	6	6	7,25 - 8,00	14	-
2,00 - 2,75	7	7	8,00 - 8,75	15	-
2,75 - 3,50	8	8	8,75 - 9,50	16	-
3,50 - 4,25	9	9	9,50 - 10,25	17	-
4,25 - 5,00	10	10	10,25 - 11,00	18	-
5,00 - 5,75	11	-	11,00 - 11,75	19	-
5,75 - 6,50	12	-	11,75 - 12,50	20	-

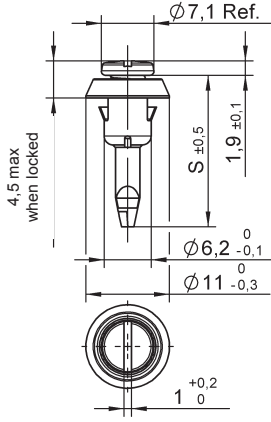
Other lengths on request.

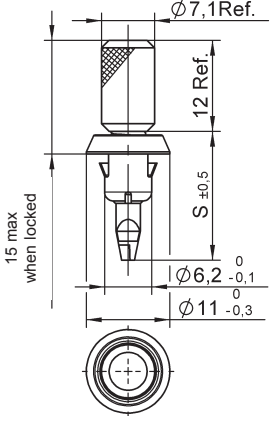
Style	Dimensions	Materials / Finish	Panel Thickness P	°C	Part No.
Slotted Recess Head 	 <p>S = 13,25 + (0,75 x length no.)</p>	Stainless steel Spring cup: Plastic (POM) / black	0,5 - 1,0	-25 up to +90	715S12- *-1BP
			1,0 - 1,5		715S12- *-2BP
			1,5 - 2,0		715S12- *-3BP
Knurled Head 	 <p>S = 13,25 + (0,75 x length no.)</p>	Stainless steel Spring cup: Plastic (POM) / black	0,5 - 1,0	-25 up to +90	715S13- *-1BP
			1,0 - 1,5		715S13- *-2BP
			1,5 - 2,0		715S13- *-3BP

Stud Installation Instructions

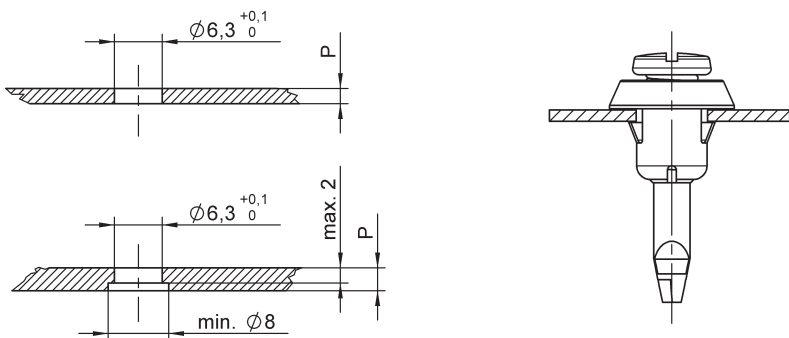
Installation Dimensions	
Panel up to 2 mm	
Panel over 2 mm	

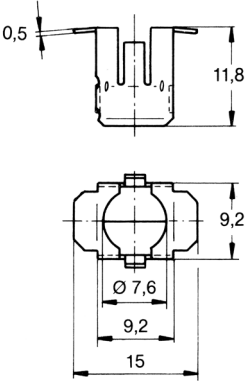
Style	Dimensions	Materials / Finish	Frame Thickness F	°C	Part No.
Receptacle 		Stainless steel	0,5 - 1,0	-25 up to +90 (See stud assembly)	715R02-1BP
			1,0 - 1,5		715R02-2BP
			1,5 - 2,0		715R02-3BP
			2,0 - 2,5		715R02-4BP

Installation Instructions

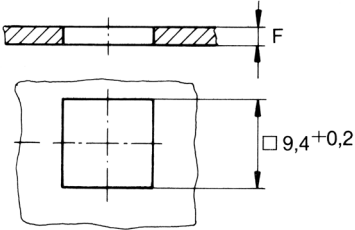
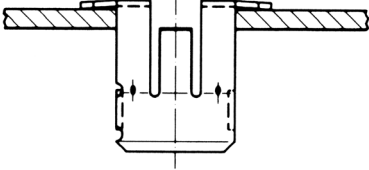
Installation Dimensions	
	

Features

Max. tensile strength 1.400 N, working load 1.200 N.
Easy and economic clip-in installation for stud and receptacle.
Also suitable for automatic installation.
1/4 turn to open – close with a push of the finger.

Selection Instructions

1. Select stud assembly according to panel thickness P, page M-2 and spring clip according to frame thickness F, page M-3.
2. Select stud length number from panel thickness P using table below, insert into stud part number * (e.g. 716S12-* -1BP).

Part no. example

Stud, slotted recess head

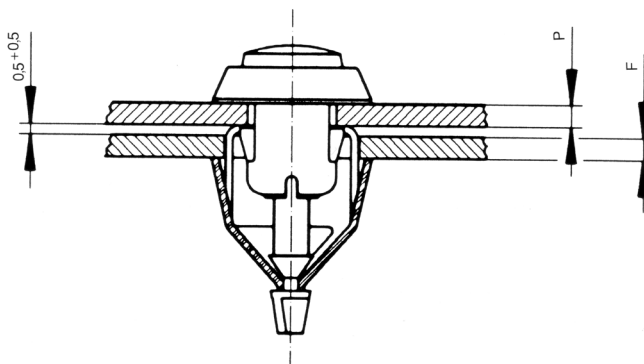
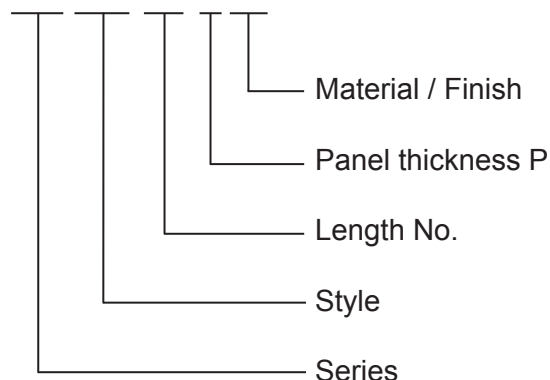

716 S12 -03 -2BP



Stud Length Table

Panel Thickness P	Stud Length No.
1,0 - 2,0	02
2,0 - 3,0	03
3,0 - 4,0	04
4,0 - 5,0	05
5,0 - 6,0	06
6,0 - 7,0	07
7,0 - 8,0	08
8,0 - 9,0	09
9,0 - 10,0	10

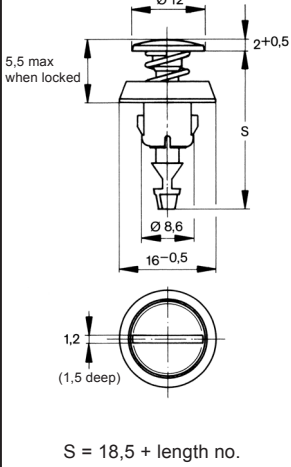
Other lengths on request.

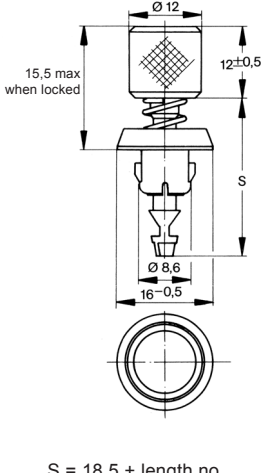
Style	Dimensions	Materials / Finish	Panel Thickness P	°C	Part No.
Slotted Recess Head 		Stainless steel Spring cup: Plastic (POM)/black	0,5 - 1,0	-25 up to +90	716S12- *-1BP
			1,0 - 1,5		716S12- *-2BP
			1,5 - 2,0		716S12- *-3BP
			2,0 - 2,5		716S12- *-4BP
			2,5 - 3,0		716S12- *-5BP
Knurled Head 		Stainless steel Spring cup: Plastic (POM)/black	0,5 - 1,0	-25 up to +90	716S13- *-1BP
			1,0 - 1,5		716S13- *-2BP
			1,5 - 2,0		716S13- *-3BP
			2,0 - 2,5		716S13- *-4BP
			2,5 - 3,0		716S13- *-5BP

* Length no. from Table, page M-1.

Stud Installation Instructions

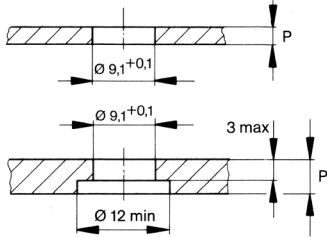
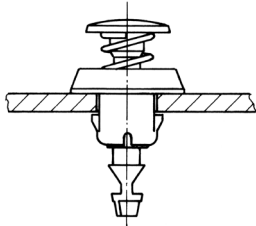
Installation Dimensions	
Panel up to 3 mm	
Panel over 3 mm	
	

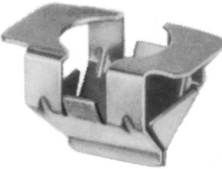
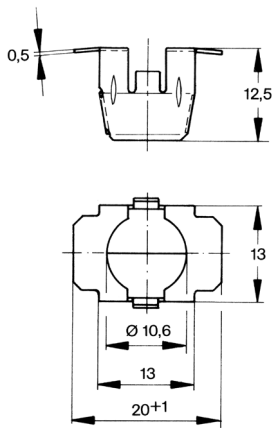
Style	Dimensions	Materials / Finish	Frame Thickness F	°C	Part No.
Spring Clip 		Stainless steel	1,0 - 1,5	-25 up to +90 (See stud assembly)	720R01-1B
			1,5 - 2,0		720R01-2B
			2,0 - 2,5		720R01-3B
			2,5 - 3,0		720R01-4B

Installation Instructions

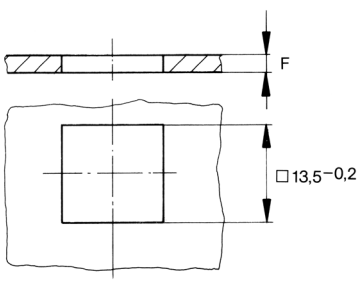
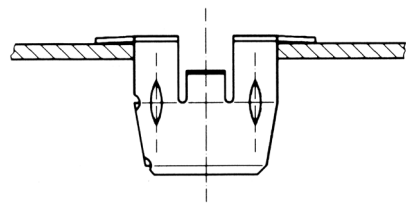
Installation Dimensions
 

Features

- Max. tensile strength 3.000 N, working load 2.500 N.
- Robust design - high strength.
- Stud assembly with protective, compensating and retaining washers.
- Rivet or screw mounting spring receptacle.
- 1/4 turn to open - close by a push of the finger.

Selection Instructions

1. Select stud assembly and spring clip, page N-2 and N-3.
2. Select compensating and retaining washers, page N-2.
3. Select stud length number from grip range G using the table below, insert into stud part number * (e.g. 717S01-* -1AGV).

Part no. example

Spring clip, rivet / screw mounting

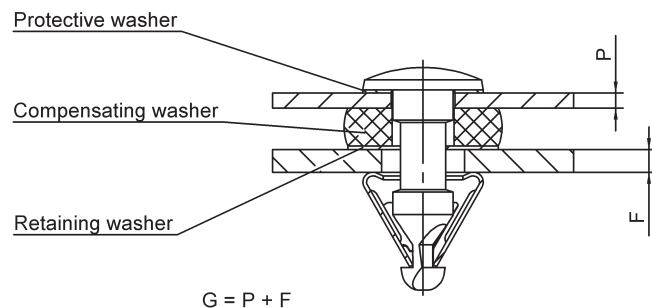
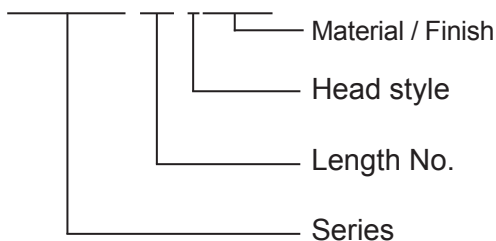

717 S01 -2 -1AGV



Stud Length Table

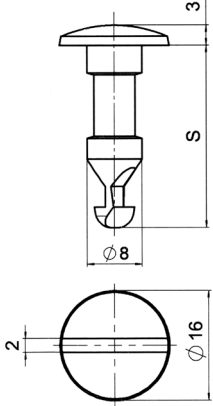

Griprange G	Stud Length No.
1,0 - 3,0	1
3,0 - 5,0	2
5,0 - 7,0	3
7,0 - 9,0	4
9,0 - 11,0	5
11,0 - 13,0	6

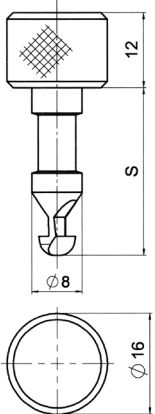
Other lengths on request.

Style	Dimensions	Materials / Finish	°C	Part No.
<p>Slotted Recess Head</p> 	 <p>$S = 20,5 + (2 \times \text{length no.})$</p>	Steel/ zinc-plated CrVI-free, clear passivation	-40 up to +100	717S01- *-1AGV
<p>Knurled Head</p> 	 <p>$S = 20,5 + (2 \times \text{length no.})$</p>	Steel/ zinc-plated CrVI-free, clear passivation	-40 up to +100	717S01- *-2AGV

* Length no. from Table, see page N-1.

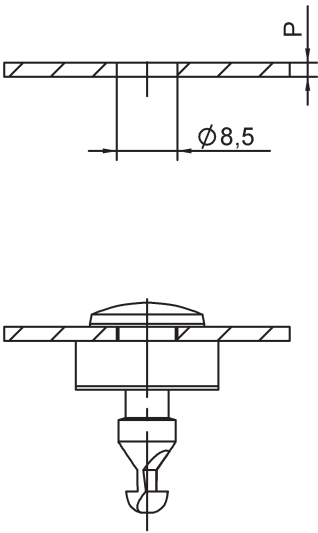
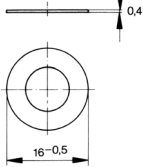
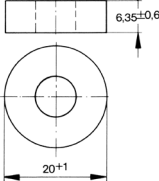
Stud Installation Instructions

Style	Dimensions	Materials / Finish	°C	Part No.
	<p>Protective washer</p> 	Plastic (PA6) / natural colour	-40 up to +100	717W02-1K
	<p>Compensating washer</p> 	Plastic (PU-foam) / anthracite	-40 up to +100	717W03-1K
	<p>Retaining washer</p> 	Plastic (PA6) / natural colour	-40 up to +100	717W01-1K

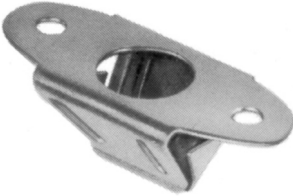
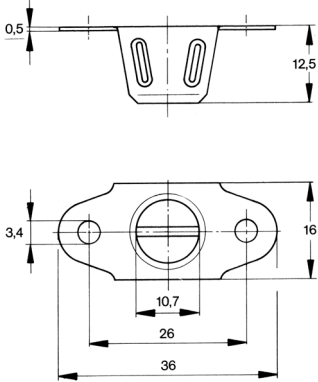
Style	Dimensions	Materials / Finish	°C	Part No.
Rivet / Screw Mounting 		Steel / zinc flake coated	-40 up to 100	717R01-1AK7

Installation Instructions

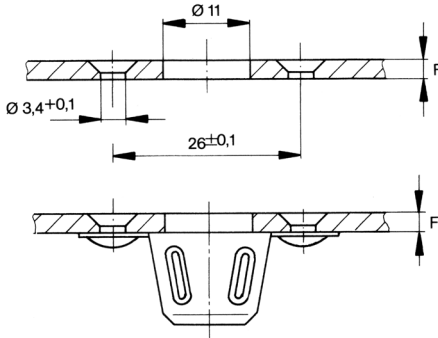
Installation Dimensions



Features

- Max. tensile strength 1.200 N, working load 800 N.
- 1/4 turn to open, close with a push of the finger
- Wide grip range
- Tool or hand operated
- Fast installation of snap-in spring receptacle.
- No tools required for the installation of the stud and washer.
- Tool operated stud has combination recess.

Selection Instructions

- Select stud assembly according to panel thickness P, page O-2 and spring clip according to frame thickness F, page O-4.
- Select Compensating washer and Retaining washer, page O-3.
- Select stud length number from panel thickness P using the formula and table below (e.g. 720S01-*B).



Part no. example

Stud, slot-cross recess

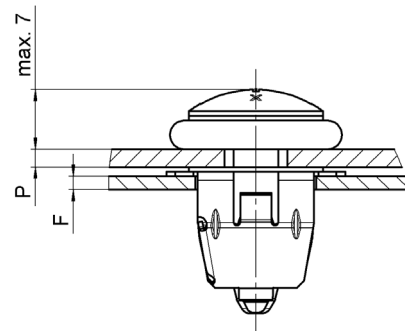
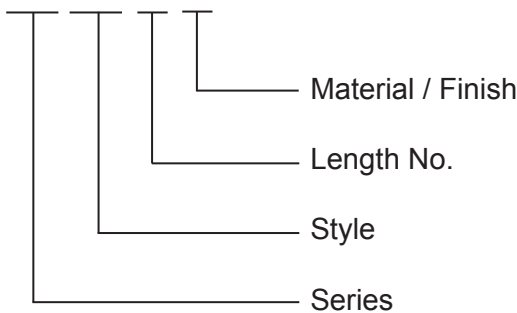
720 S01 -1 B



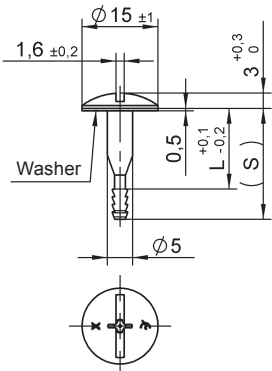

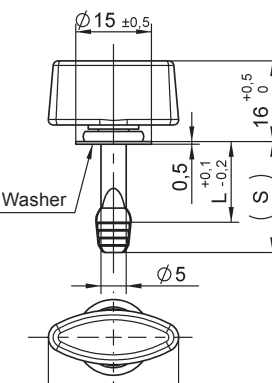
Panel Thickness P	Slot-Cross Recess Length No.	Wing Head Stud Length No.	Dimension L +0,1/-0,2	Dimension (S)
1,00 - 4,00	1	1	16	21
4,00 - 7,00	2	2	19	24
7,00 - 10,00	3	3	22	27

Style	Dimensions	Materials / Finish	°C	Part No.
Slot-Cross Recess Head 	 <p>L + (S) see table page O-1</p>	Stainless steel Washer: PA6 natural	-20 up to +70	720S01-*B
Fixed Wing Handle Plastic 	 <p>L + (S) see table page O-1</p>	Stainless steel Knob: PA6 black Washer: PA6 natural	-20 up to +70	720S02-*B

* Length no. from Table, see page O-1.

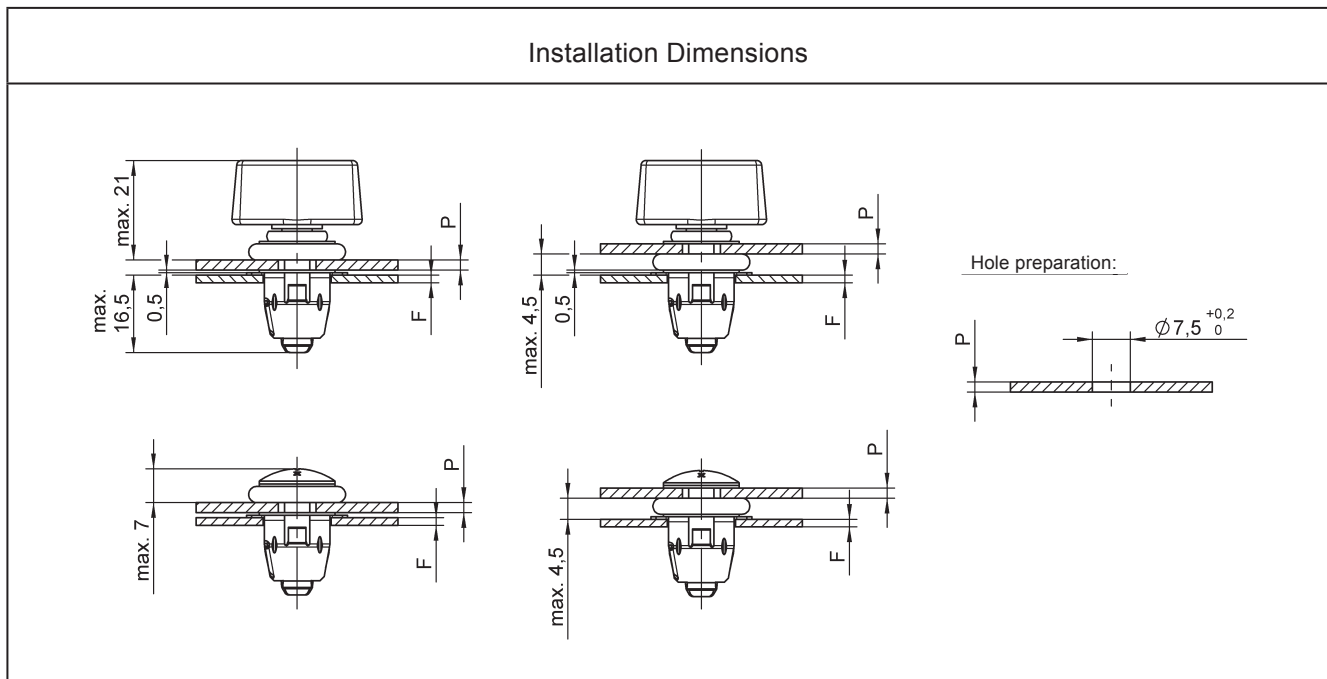
Stud Installation Instructions

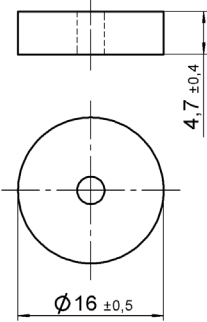
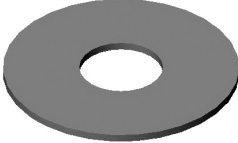
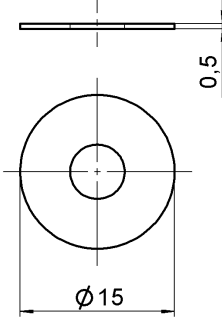

Style	Dimensions	Materials / Finish	°C	Part No.
<p>Compensating Washer</p> 		PU - Elastomer yellow	-20 up to +70	720W01-2K
<p>Retaining Washer</p> 		Polyamid natural	-20 up to +70	50E15-1K

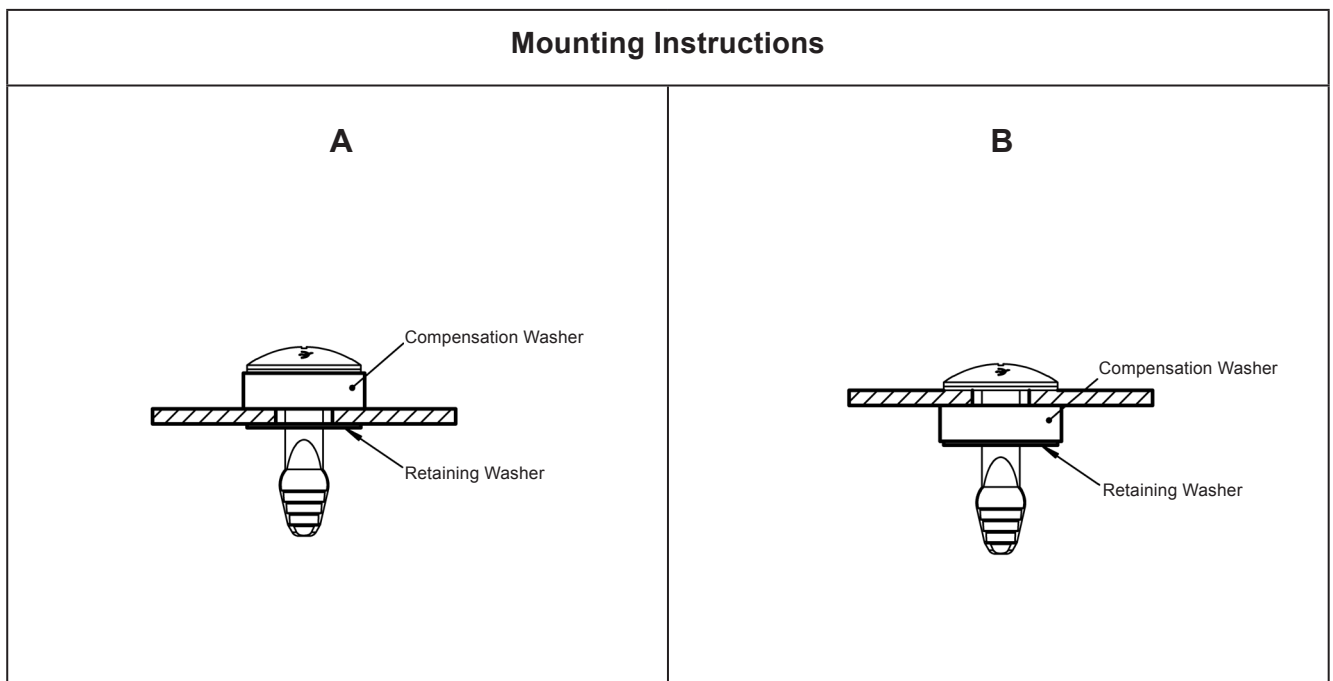

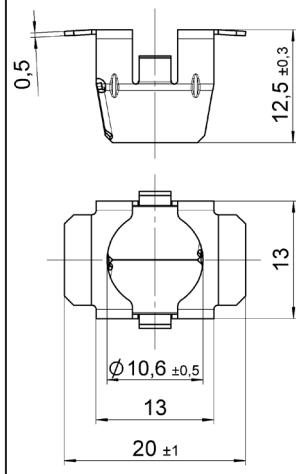
Style	Dimensions	Materials / Finish	Frame Thickness F	°C	Part No.
Spring Clip 		Stainless steel	1,0 - 1,5	-20 up to +70	720R01-1B
			1,5 - 2,0		720R01-2B
			2,0 - 2,5		720R01-3B
			2,5 - 3,0		720R01-4B

Installation Instructions

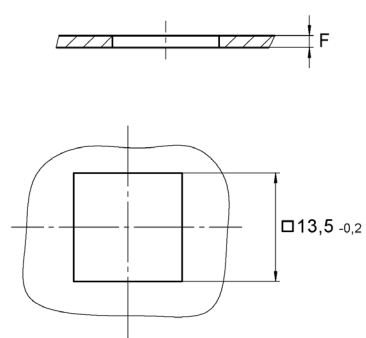
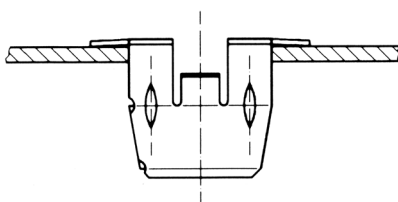
Installation Dimensions	
	

Part No.	Page	Part No.	Page	Part No.	Page
15/32-32NS-2B	C3,F12	50E70-*AGV	D2	716S12- *-1BP	M2
15S1- *-1AD	K2	50E71-*AGV	E2	716S12- *-2BP	M2
15S1- *-1AJ	K2	50E8-*AGV	E2	716S12- *-3BP	M2
15S11-1CJ	K2	50E8-*S	E2	716S12- *-4BP	M2
212-12S	F9	50E8-*W0AGV	E3	716S12- *-5BP	M2
214-16S	G10	50E8-*WAGV	E3	716S13- *-1BP	M2
244-16S	G11	50E8-*WS	E3	716S13- *-2BP	M2
244-16SC	G11	50E8-*W0S	E3	716S13- *-3BP	M2
2600-*S	F3	50E80-*AGV	D4	716S13- *-4BP	M2
2600-*SW	F3	50E80-*CP	D4	716S13- *-5BP	M2
2600-SW	C2,F7,F8	50E81-*AGV	E4	717R01-1AK7	N3
26R1-1	F10	50E81-*CP	E4	717S01- *-1AGV	N2
26R16-1FGV	F9	50E82-*AGV	D4	717S01- *-2AGV	N2
26R18-1-1AA	F9	50E82-*CP	D4	717W01-1K	N2
26S34-*	F5	50E83-*AGV	E4	717W02-1K	N2
26S38-*	F3	50E83-*CP	E4	717W03-1K	N2
26S39-*	F3	50E90-*AGV	D2	720R01-1B	M3,O4
26S42-*	F3	50E91-*AGV	E2	720R01-2B	M3,O4
26S51-*	F3	50S12-0-1AA	D5	720R01-3B	M3,O4
2700-*S	F6	50S12-1-1AA	D5	720R01-4B	M3,O4
312-12S	F10	50S12-2-1AA	D5	720S01-*B	O2
312-12WS	F10	50S12-3-1AA	D5	720S02-*B	O2
4002-GS	G8	50S12-4-1AA	D5	720W01-2K	O3
4002-HS	G8	50T01-1DR	D6,E5	991R2-1AGV	H5
4002-NS	G8	50W17-1BP	D6,E5	991R2-1BP	H5
4002-OS	G8	50W204-01K	D5,E5,G7	991R2-2AR	H5
4002-SW-SS	D5,E5,G7	5R2-3	B4	991R2-3AZ	H5
4002T02-1BP	G7	5S3-2	B3	991R2-3AGV	H5
4P3-1	F8,G7	5S15-*	B2	991R2-3BP	H5
50E15-1K	O3	5S27-*	B2	991R6-1AK7	H5
50E18-*AGV	D4	5S72-5-1AA	B3	991S01- *-1AGV	H2
50E19-*AGV	E4	5S72-9-1AA	B3	991S01- *-1BP	H2
50E20-1AK7	D6	713S*- *AE	J2	991S02- *-1AGV	H2
50E20-2AK7	D6	715R02-1BP	L3	991S02- *-1BP	H2
50E21-*AGV	D2	715R02-2BP	L3	991S03- *-1AGV	H2
50E21-*S	D2	715R02-3BP	L3	991S03- *-1BP	H2
50E21-*W0AGV	D3	715R02-4BP	L3	991S04- *-1AGV	H2
50E21-*WAGV	D3	715S12- *-1BP	L2	991S05- *-1AGV	H3
50E21-*WS	D3	715S12- *-2BP	L2	991S17-1K	H4
50E2-3BP	D5,E5	715S12- *-3BP	L2	991S2991-*AGV	H3
50E60-*AGV	D3	715S13- *-1BP	L2	991S30-*AGV	H3
50E61-*AGV	E3	715S13- *-2BP	L2	991W02-1BP	H4
50E7-*AGV	E4	715S13- *-3BP	L2	991W03-1BP	H4

Part No.	Page
991W04-1BP	H4
991W120-08K	H5
991W120-10K	H5
991W120-15K	H5
991W120-20K	H5
99E10-01	C3,F11
99N10-01A1	C3,F12
99R10-01A1	C3,F11
991R2-2AR	H5
99W10-01A1	C2
AN6227-B3	F7
AN6227-B6	F7
D214-16FGV	G10
D214-16NFGV	G10
D244-16-FGV	G11
D244-16C-FGV	G11
D4002-*AGV	G4
D4002-*BP	G4
D4002-*WAGV	G4
D4002-*WBP	G4
D4002-N-AGV	G8
D4002-O-AGV	G8
D4002-P-AGV	G8
D4002-P-BP	G8
D4002-R-AGV	G8
D4002-R-BP	G8
D4002-S-AGV	G8
D4002-S-BP	G8
D4002-T-AGV	G8
D4002-T-BP	G8
D4002-G-AGV	G8
D4002-H-AGV	G8
D4002I-*AGV	G6
D40E22-*AGV	G5
D40E28-*AGV	G5
D40E28-*BP	G5
D40G11-3K	G6
D40R12-1FGV	G10
D40S39-1K	G6
D40S47-*AGV	G5
D40S5-*AGV	G4
D40S5I-*AGV	G6
D40S5-*BP	G4

Part No.	Page
D40W02-1DR	G12
D40W02-2DR	G12
R4G-3	G9
T107-1	K2
T26	G9
T98-1	C2,F8
V15R13-1-1AB	K4
V15R14-1-1AB	K4
V15S20-* -1AGV	K3
V212-12-1FGV	F9
V212-12-2FGV	F9
V212-12N-1FGV	F9
V244-16T1	G12
V244-16T1C	G12
V244-16TS1	G12
V244-16TS1C	G12
V2600-LW-7	C2,F7,F8
V26R6-1AGV	F9
V26S01-*AGV	F3
V26S02-*AGV	F3
V26S04-*AGV	F3
V26S06-* -1AGV	F4
V26S07-* -1AGV	F4
V26S08-* -1AGV	F4
V26S22-*AGV	F5
V27S01-*AGV	F6
V27S02-*AGV	F6
V27W01-1AN	F8
V312-12AGV	F10
V40G26-1BP	G9
V40G26-1N	G9
V50R1-1-1AGV	E6,G11
V50R1-1-1BP	E6, G11
V50R1-1-2AR	E6,G11
V50R1-1-2AZ	E6,G11
V50R4-2-1AK7	D6
V5R2-1AK7	B4
V5S21-*AGV	B2
V5W3-1AG	B3
V5S5-*AGV	B2
V936S05-3-1AA	I1
V936S05-4-1AA	I1
V936S11-3-1AA	I1

Part No.	Page
V936S11-4-1AA	I1
V99S10-*AG	C2



	Page
General Information	A-2
Important Information	A-3
Overview on latches	A-4

Tension Latches

V934L Series	B-1 - B-2
V95L Series	C-1 - C-2
V96L Series	D-1 - D-2
1429L Series	E-1 - E-5
V951L Series	F-1 - F-8
V917L & 1449L Series	G-1 - G-5
V18L Series	H-1 - H-4
V46L Series	I-1 - I-2

Index



electrical cabinets



laboratory equipment



machine construction



agriculture



construction



solar



truck



electronic equipment



lighting interior



mould making



automotive/ racing



rail



trailer



wind

The Camloc brand was established in 1937. Since that time our fastening systems have been successfully integrated into numerous applications within many different industries.

Our customers benefit from our more than 80 years of fastening experience.

We provide local support for innovative, high quality fastening systems supplied globally to the strictest environmental and working conditions.



IATF 16949:2016



ISO 14001:2015

Your Howmet Fastening Systems team

Disclaimer:

Parts listed are subject to technical changes. All dimensions in mm. All information is correct to the best of our knowledge at the time of printing. No liability for disadvantages caused by printing errors or false application.

How It Operates

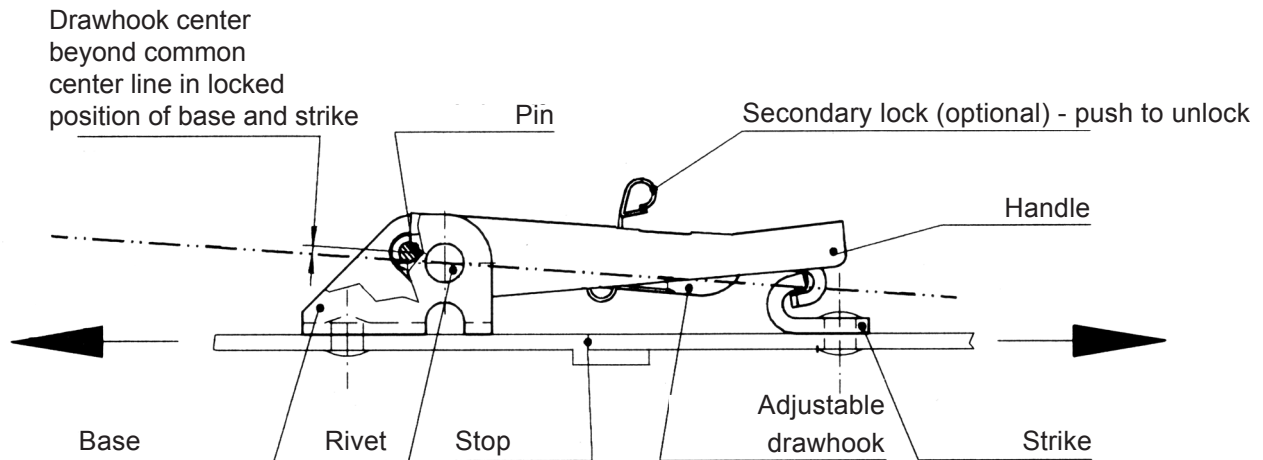

- Tension latches provide a quick release yet secure locking mechanism. They can take high tensile loads. Shear forces must be kept off the tension latch by the assembly design.
- Through lever action, the panels connected with the tension latch and the strike are pulled together. If necessary, a stop must be provided.
- Positive lock is achieved when drawhook center is beyond the common center line of the base and strike.

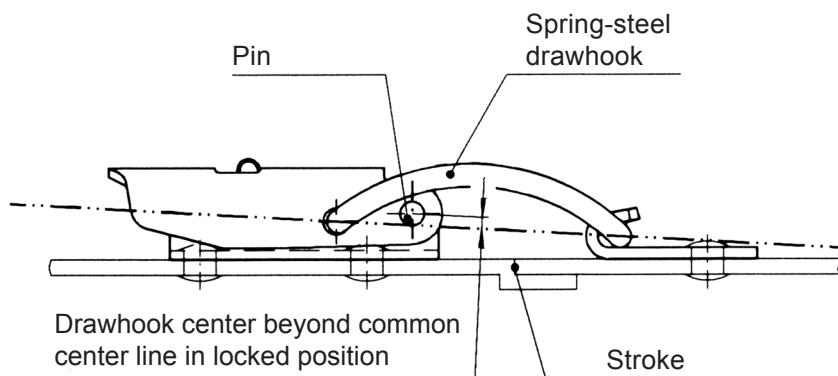

- For unlocking, the secondary lock, if fitted, is operated and the handle lifted. For locking, the secondary lock automatically engages.
- Most of the tension latches can be adjusted by a threaded drawhook. For non-threaded drawhook series the spring steel or wire drawhook gives tolerance compensation and joint tension.

Click here: [Camloc Draw Latch](#) (Youtubelink)



Overview Latches

Series	Max. tensile strength	Working load	without secondary lock	with secondary lock	with hasp	to rivet on or to screw on	to weld on	adjustable drawhook	carbon steel with surface treatment	Stainless steel	Pages
V934L	550 N	310 N	X	X		X			X	X	B1-B2
95L	445 N	220 N	X			X			X	X	C1-C2
V96L	1.000 N	650 N	X			X			X		D1-D2
1429L	1.500 N	1.000 N	X	X		X			X	X	E1-E5
V951L	2.300 N	1.550 N	X	X	X	X	X	X	X	X	F1-F6
V917L	3.600 N	2.700 N	X	X	X	X	X	X	X	X	G1-G5
V18L	6.000 N	4.200 N	X	X	X	X	X	X	X	X	H1-H4
V46L	4.400 N	3.000 N	X			X	X	X	X		I1

* Limitations within series possible. Please see (foot) notes at catalogue pages.

Max. tensile strength 550 N
Working load 310 N

Style	Dimensions	Materials / Finish	Part No.
		Stainless steel Steel / zinc-plated, CrVI-free, clear passivation	V934L01-1-1BP V934L01-1-1AGV
With secondary lock 		Stainless steel Steel / zinc-plated, CrVI-free, clear passivation	V934L01-1X1BP V934L01-1X1AGV

Strikes

Style	Dimensions	Materials / Finish	D	Part No.
		Stainless steel ¹⁾ Steel / zinc-plated, CrVI-free, clear passivation	2,6	V934L02-1BP V934L02-1AGV

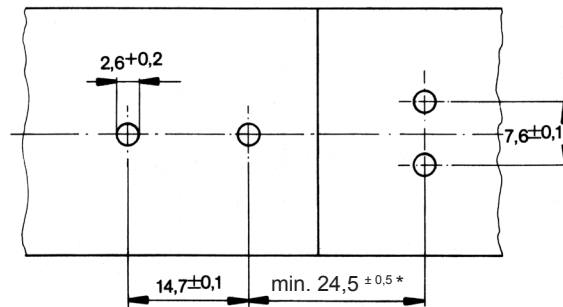
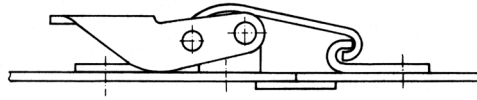

Dimensions



*please take into account the application preload and tolerance requirements

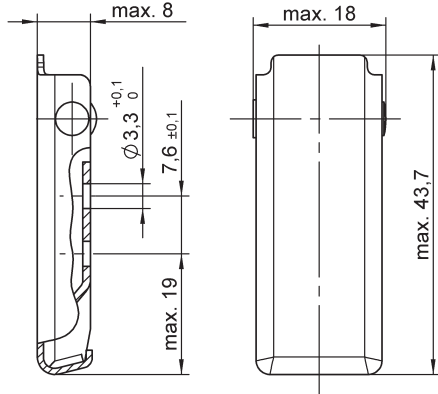

Max. tensile strength 445 N, working load 220 N
 Handle conceals all interior parts and strike
 Self-compensating spring steel drawhook
 Low profile

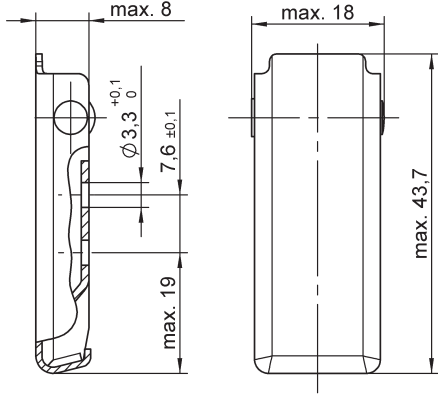
Style	Dimensions	Materials / Finish	Part No.
<p>Self-compensating spring steel drawhook</p> 		Stainless steel	V95L07-1-1BC
<p>Self-compensating spring steel drawhook</p> 		Steel / chrome-plated Interior parts: Steel / zinc-plated, CrVI-free, clear passivation	V95L15-1BD

Strike

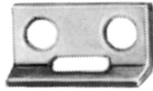
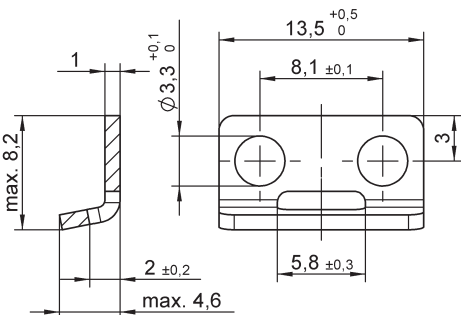
Style	Dimensions	Materials / Finish	Part No.
		Stainless steel	V95H07-1-1BP

Dimensions

Spring steel drawhook tension latch / strike

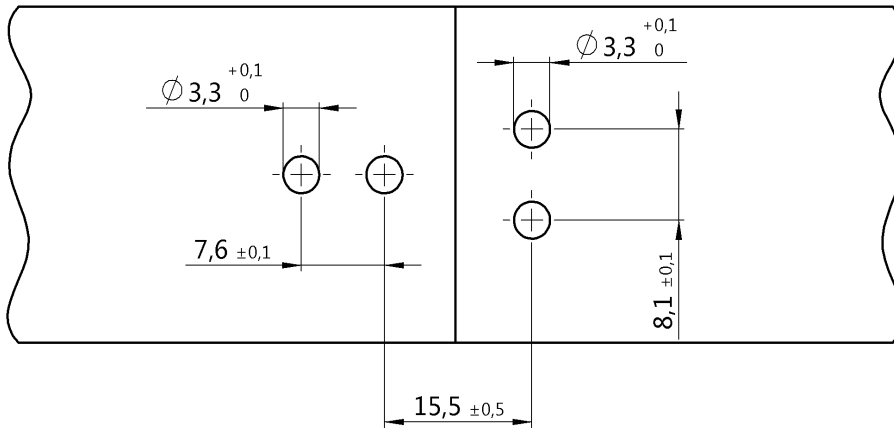
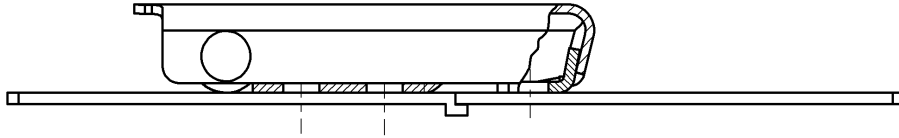

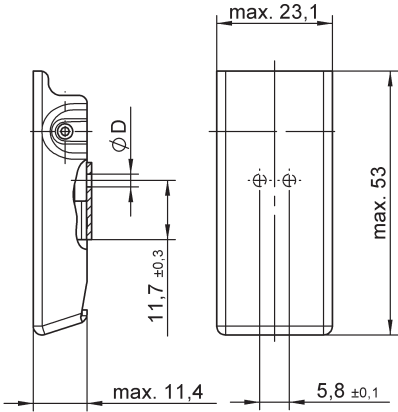

Max. tensile strength 1.000 N, working load 650 N.
Handle conceals all interior parts and strike
Self-compensating spring steel drawhook
Low profile

Style	Dimensions	Materials / Finish	D	Part No.
Self-compensating spring steel drawhook 		Steel / zinc-plated, CrVI-free, clear passivation	2,5	V96L01-1-1A0
			3,2	V96L01-1-2A0
		Steel / chrome-plated Interior parts: Steel / zinc-plated, CrVI-free, clear passivation	2,5	V96L01-1-1AG
			3,2	V96L01-1-2AG

Strike

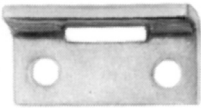
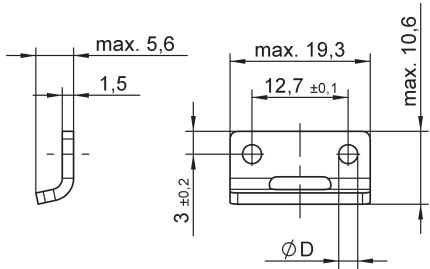

Style	Dimensions	Materials / Finish	D	Part No.
		Steel / zinc-plated, CrVI-free, clear passivation	2,5	V96H01-1-1A0
			3,2	V96H01-1-2A0

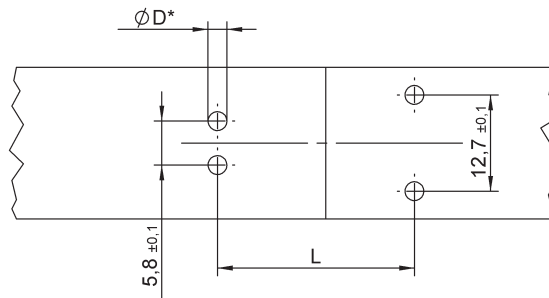
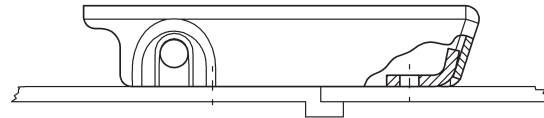
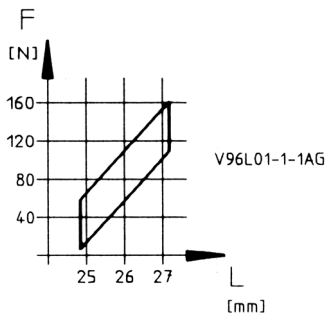
Dimensions



* Ø D see selected version.

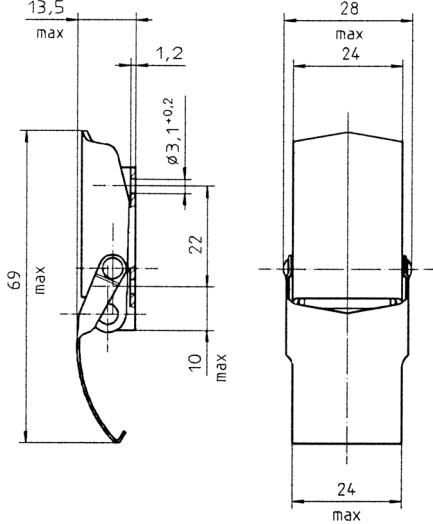

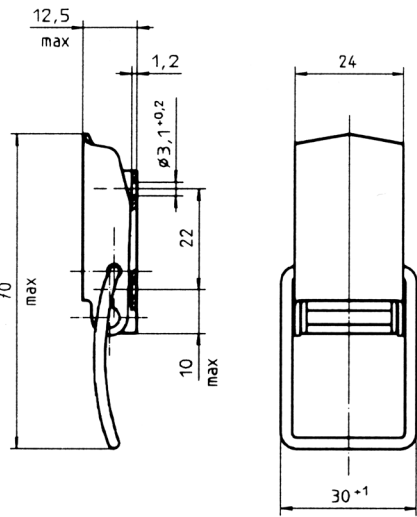
Max. tensile strength 1.500 N, working load up to 1.000 N, see footnotes.
Available with secondary lock
Three different drawhook types available

Style	Dimensions	Materials / Finish	D	Part No.
Spring steel drawhook 		Steel / zinc-plated, CrVI-free, clear passivation ¹⁾	3,1	1429L02-1-1AG
		Stainless steel ²⁾	3,1	1429L02-1-1BP
Wire drawhook 		Steel / zinc-plated, CrVI-free, clear passivation ¹⁾	3,1	1429L02-2-1AG
		Stainless steel ³⁾	3,1	1429L02-2-1BP

¹⁾ Max. tensile strength: 450 N with 1429L8-1AG strike, working load 330 N.

²⁾ Max. tensile strength: 300 N with 1429L8-1BP strike, working load 210 N.

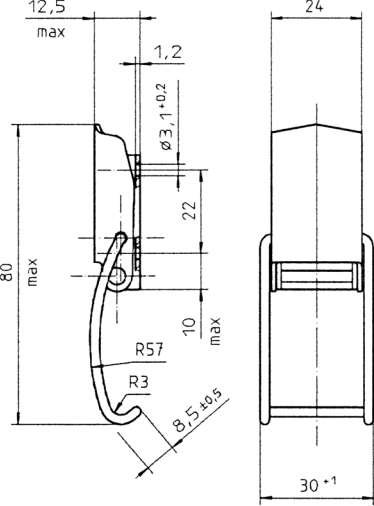
³⁾ Max. tensile strength: 1.500 N with 1429L9-1AG / -1BP strike, working load 1.000 N.

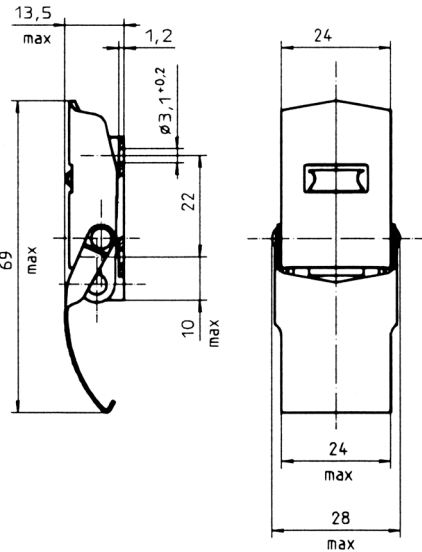
Style	Dimensions	Materials / Finish	D	Part No.
Hooked wire drawhook 		Steel / zinc-plated, CrVI-free, clear passivation ¹⁾	3,1	1429L02-3-1AG
		Stainless steel ¹⁾	3,1	1429L02-3-1BP
Spring steel drawhook and secondary lock 		Steel / zinc-plated, CrVI-free, clear passivation ²⁾	3,1	1429L02-1X1AG
		Stainless steel ³⁾	3,1	1429L02-1X1BP

¹⁾ Max. tensile strength: 1.100 N with 1429L9-1AG / -1BP strike, working load 800 N.
or in conjunction with mating component profile.

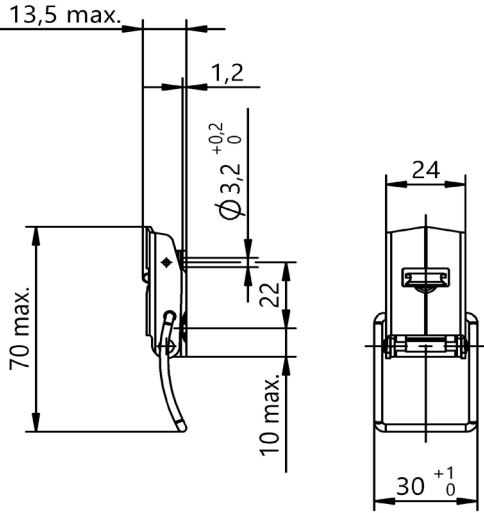
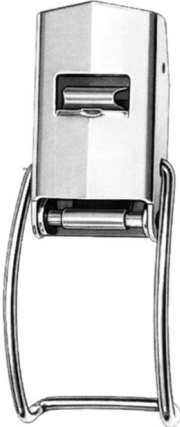
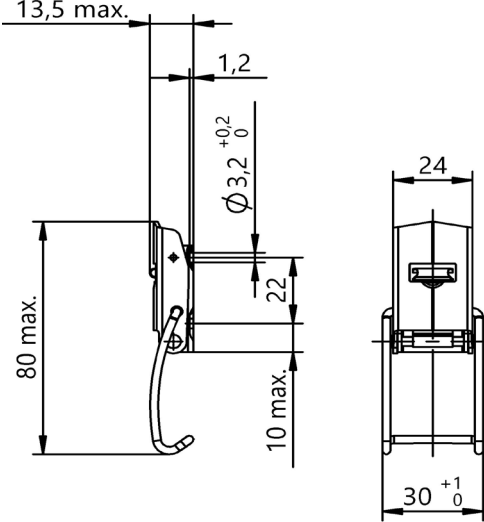

²⁾ Max. tensile strength: 450 N with 1429L8-1AG strike, working load 330 N.

³⁾ Max. tensile strength: 300 N with 1429L8-1BP strike, working load 210 N.

Style	Dimensions	Materials / Finish	D	Part No.
Wire drawhook and secondary lock 		Steel / zinc-plated, CrVI-free, clear passivation ¹⁾	3,1	1429L02-2X1AG
		Stainless steel ¹⁾	3,1	1429L02-2X1BP
Hooked wire drawhook and secondary lock 		Steel / zinc-plated, CrVI-free, clear passivation ²⁾	3,1	1429L02-3X1AG
		Stainless steel ²⁾	3,1	1429L02-3X1BP

¹⁾ Max. tensile strength: max. 1.500 N with 1429L9-1AG / -1BP strike, working load 1.000 N.

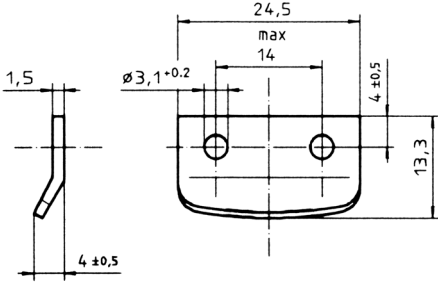
²⁾ Max. tensile strength: max. 1.100 N with 1429L9-1AG / -BP strike, working load 800 N.
or in conjunction with mating component profile.

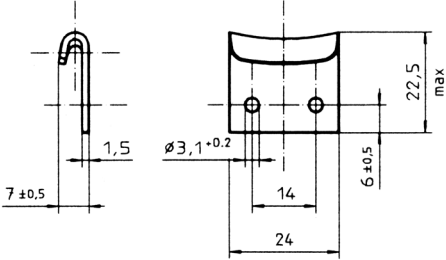
Style	Dimensions	Materials / Finish	D	Part No.
<p>For use with spring steel drawhook</p> 		<p>Steel / zinc-plated, CrVI-free, clear passivation</p> <p>Stainless steel</p>	<p>3,1</p> <p>3,1</p>	<p>1429L8-1AG</p> <p>1429L8-1BP</p>
<p>For use with wire drawhook</p> 		<p>Steel / zinc-plated, CrVI-free, clear passivation</p> <p>Stainless steel</p>	<p>3,1</p> <p>3,1</p>	<p>1429L9-1AG</p> <p>1429L9-1BP</p>

Dimensions

Spring steel drawhook tension latch / strike

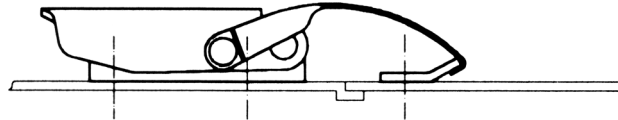

1429L02-1-^{*}
1429L8-^{*}

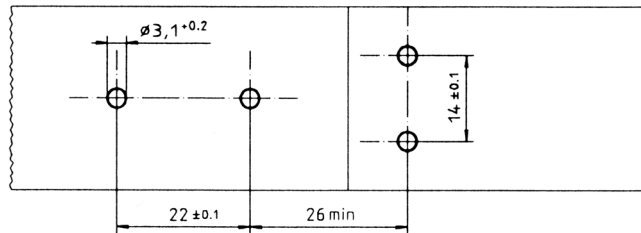

Wire drawhook tension latch / strike

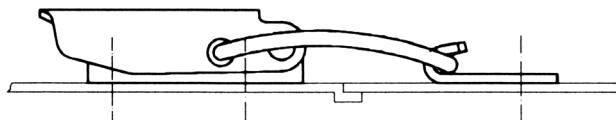

1429L02-2-^{*}
1429L9-^{*}

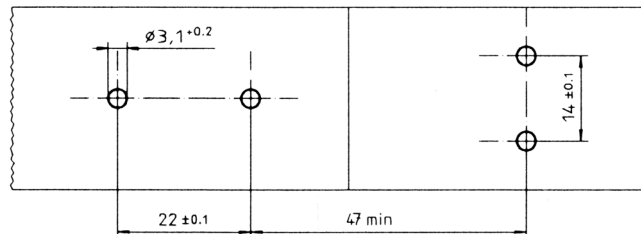

Hooked wire drawhook tension latch / mating component profile

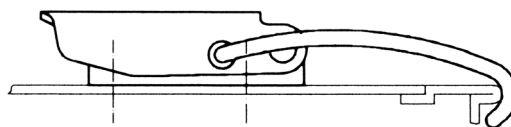

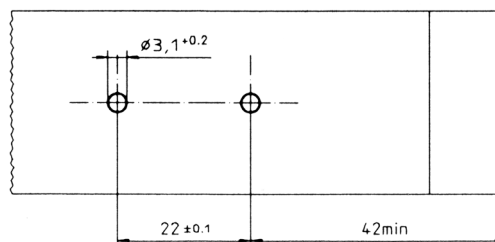

1429L02-3-^{*}
(1429L9-^{*})



Max. tensile strength 2.300 N, working load max 1.550 N, see footnotes.

Adjustable drawhook

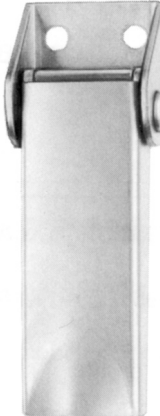
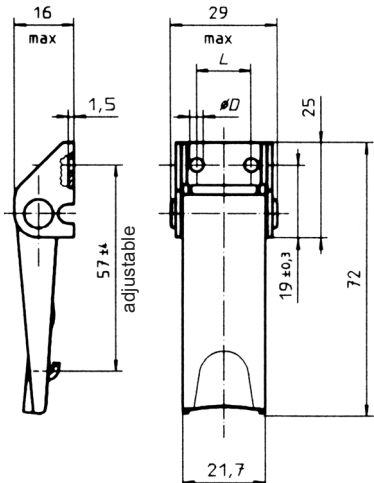
Available with secondary lock and hasp

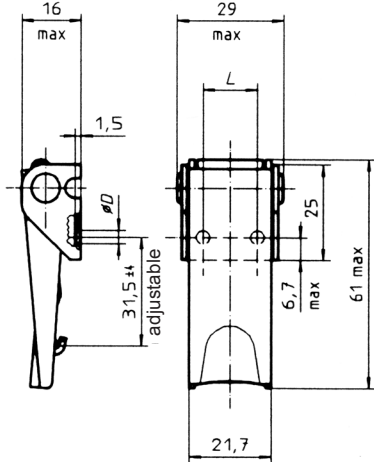
Style	Dimensions	Materials / Finish	Mounting Type ¹⁾	D	L	Part No.
Open base 		Steel / zinc-plated, CrVI-free, clear passivation ²⁾	N	3,6	14,3	V951L02-1-1AGV
		Steel / zinc-plated, CrVI-free, clear passivation ²⁾	N	4,2	12,7	V951L02-1-5AGV
		Steel / zinc-plated, CrVI-free, clear passivation Base: Steel / zinc-plated ²⁾	S	-	-	V951L02-1-2AGV
		Steel / chrome-plated Interior parts: Steel / zinc-plated, CrVI-free, clear passivation ²⁾	N	3,6	14,3	V951L02-1-1AD
		Stainless steel ³⁾	N	3,6	14,3	V951L02-1-1BP
		Stainless steel ³⁾	N	4,2	12,7	V951L02-1-5BP
		Stainless steel ³⁾	S	-	-	V951L02-1-2BP
Concealed base ⁴⁾ 		Steel / zinc-plated, CrVI-free, clear passivation	N	3,6	14,3	V951L03-1-1AGV
		Steel / zinc-plated, CrVI-free, clear passivation	N	4,2	12,7	V951L03-1-5AGV
		Steel / chrome-plated Interior parts: Steel / zinc-plated, CrVI-free, clear passivation	N	3,6	14,3	V951L03-1-1AD
		Stainless steel	N	3,6	14,3	V951L03-1-1BP
		Stainless steel	N	4,2	12,7	V951L03-1-5BP

¹⁾ Mounting type: N = With holes for riveting or screw fixing



S = Without holes, for welding

²⁾ Max. tensile strength: 2.300 N with V951L7-*A*, V951L52-1A* strike, working load 1.550 N.

2.000 N with V951L50-1A* strike, working load 1.300 N.

³⁾ Max. tensile strength: 1.500 N with V951L7-*BP*, V951L50-1BP, V951L52-1BP strike, working load 1.000 N.

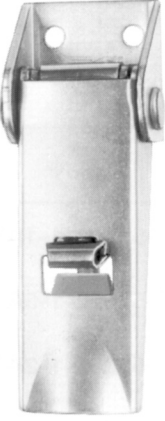
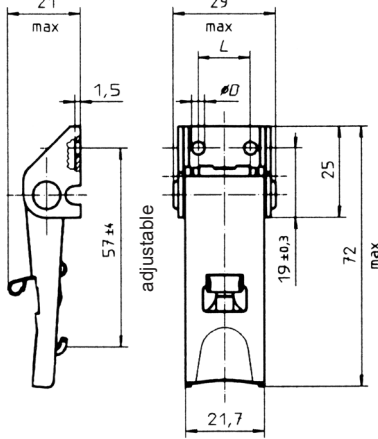

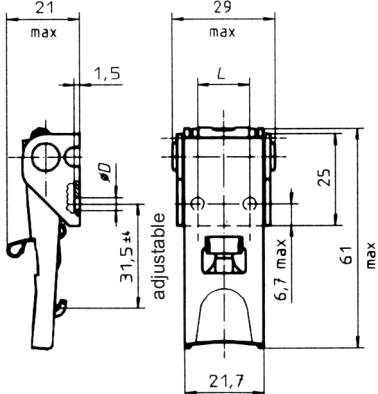

⁴⁾ Due to the mounting geometry, tensile strength reduced to approx. 1200 N, working load 800 N.

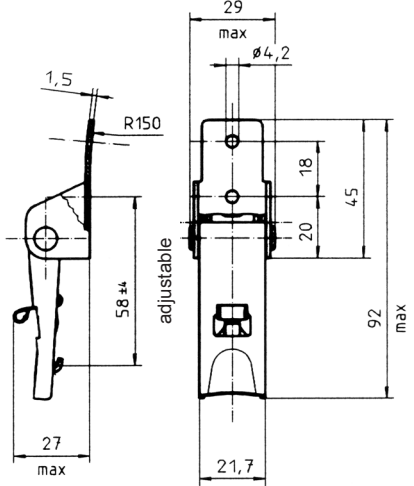
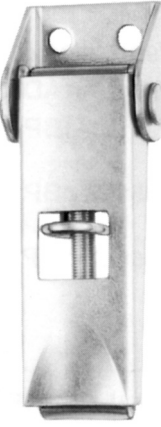
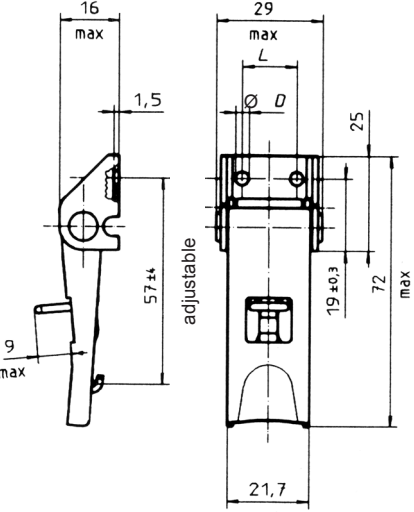
Style	Dimensions	Materials / Finish	Mounting Type ¹⁾	D	L	Part No.
Secondary lock, open base 		Steel / zinc-plated, CrVI-free, clear passivation ²⁾	N	3,6	14,3	V951L04-1X1AGV
		Steel / zinc-plated, CrVI-free, clear passivation ²⁾	N	4,2	12,7	V951L04-1X5AGV
		Steel / chrome-plated Interior parts: Steel / zinc-plated, CrVI-free, clear passivation Secondary lock: Stainless steel	N	3,6	14,3	V951L04-1X1AD
		Stainless steel ³⁾	N	3,6	14,3	V951L04-1X1BP
		Stainless steel ³⁾	N	4,2	12,7	V951L04-1X5BP
		Stainless steel ³⁾	S	-	-	V951L04-1X2BP
Secondary lock, concealed base ⁴⁾ 		Steel / zinc-plated, CrVI-free, clear passivation	N	4,2	12,7	V951L03-1X5AGV
		Steel / chrome-plated Interior parts: Steel / zinc-plated, CrVI-free, clear passivation Secondary lock: Stainless steel	N	3,6	14,3	V951L03-1X1AD
		Stainless steel	N	3,6	14,3	V951L03-1X1BP
		Stainless steel	N	4,2	12,7	V951L03-1X5BP

For footnotes refer to page F-1.

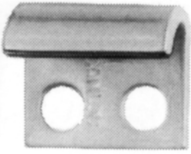
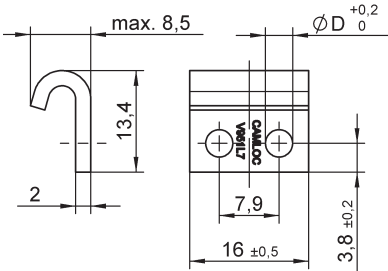
Style	Dimensions	Materials / Finish	Mounting Type ¹⁾	D	Part No.
Secondary lock, high base 		Steel / zinc-plated, CrVI-free, clear passivation Secondary lock: Stainless steel ²⁾	N	4,2	V951L05-1X1AGV
		Stainless steel ³⁾	N	4,2	V951L05-1X1BP
Hasp 	 <p>Hasp for Padlock Ø 6 max.</p>	Steel / zinc-plated, CrVI-free, clear passivation ²⁾ Base: Steel / zinc-plated	S	-	V951L01-1Y2AGV
		Steel / zinc-plated, CrVI-free, clear passivation ²⁾	N	4,2	V951L01-1Y5AGV

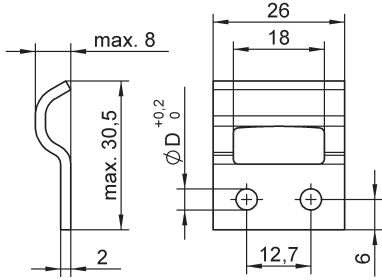
For footnotes refer to page F-1.

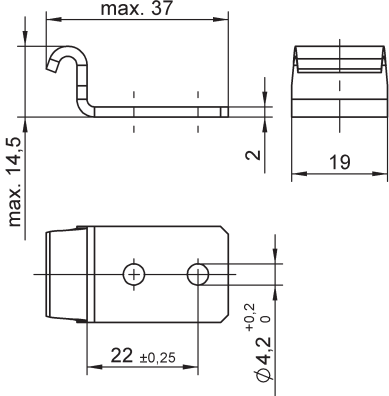
Style	Dimensions	Materials / Finish	Mounting Type ¹⁾	D	Part No.
Open 		Steel / zinc-plated, CrVI-free, clear passivation	N	3,6	V951L7-1AGV
		Steel / zinc-plated, CrVI-free, clear passivation	N	4,2	V951L7-5AGV
		Steel / zinc-plated	S ²⁾	-	V951L7-2AZ
		Steel / chrome-plated	N	3,6	V951L7-1AD
		Stainless steel	N	3,6	V951L7-1BP
		Stainless steel	N	4,2	V951L7-5BP
		Stainless steel	S	-	V951L7-2BP
Closed 		Steel / zinc-plated, CrVI-free, clear passivation	N	4,2	V951L50-1AGV
		Stainless steel	N	4,2	V951L50-1BP
		Stainless steel	N	3,6	V951L50-2BP
		Stainless steel	S	-	V951L50-3BP
Corner mounting 		Steel / zinc-plated, CrVI-free, clear passivation	N	4,2	V951L52-1AGV
		Stainless steel	N	4,2	V951L52-1BP

¹⁾ Mounting type: N = With holes for riveting or screw fixing
S = Without holes, for welding

²⁾ Material C45, HRC 36-39 steel, please use high-alloy filler welding rods

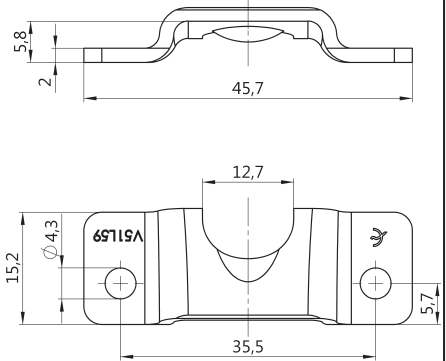
Product	Dimensions	Materials / Finish	Mounting Type	D	Part No.
<p>wide Version</p> 		zinc-nickel plated transparent, CrVI-free passivated and sealed	N	4,3	V51L59-1ASNV

- 1) Befestigung: N = mit Bohrungen zum Nieten bzw. Schrauben
S = ohne Bohrungen zum Schweißen
- 2) Werkstoff: Stahl C45, HRC 36-39, bitte hochlegierte Schweißzusatzwerkstoffe verwenden.

Accessories

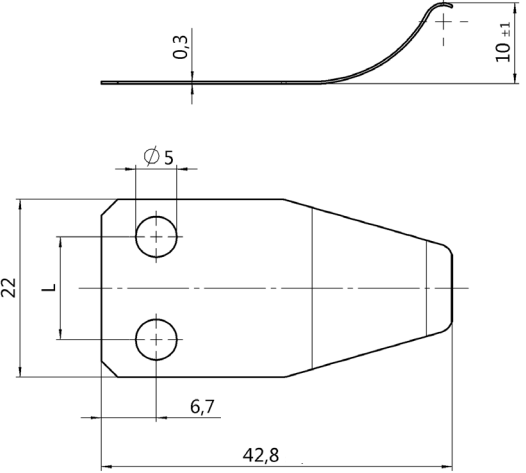
Dimensions	Material / Finish	Hole Distance L	D	Part No.
<p>Lift Spring</p> 	stainless steel / passivated	14,3	5,0	V951L61-4BP
	stainless steel / passivated	12,7	5,0	V951L61-5BP

This lift spring can only be used in combination with latches of V951L series with open base.

Dimensions

Open-base tension latch / open strike

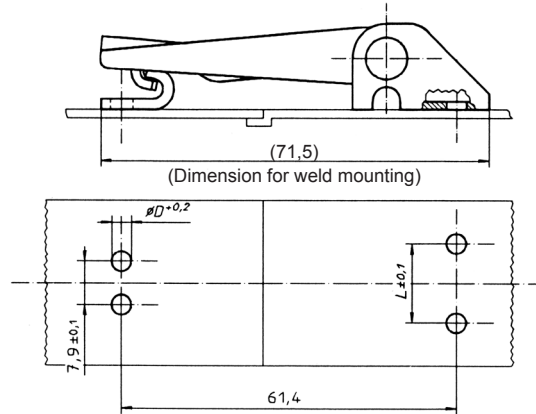

V951L02-
V951L04-
V951L01-*

V951L7-*

Select diameter D and distance L in accordance with the strike and tension latch style.

Concealed-base tension latch / open strike

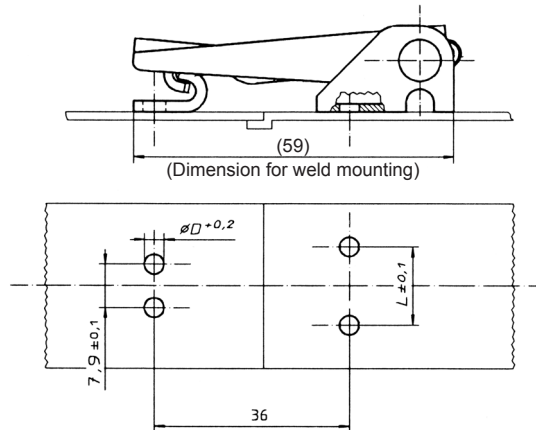

V951L03-*

V951L7-*

Select diameter D and distance L in accordance with the strike and tension latch style.

Open-base tension latch / closed strike

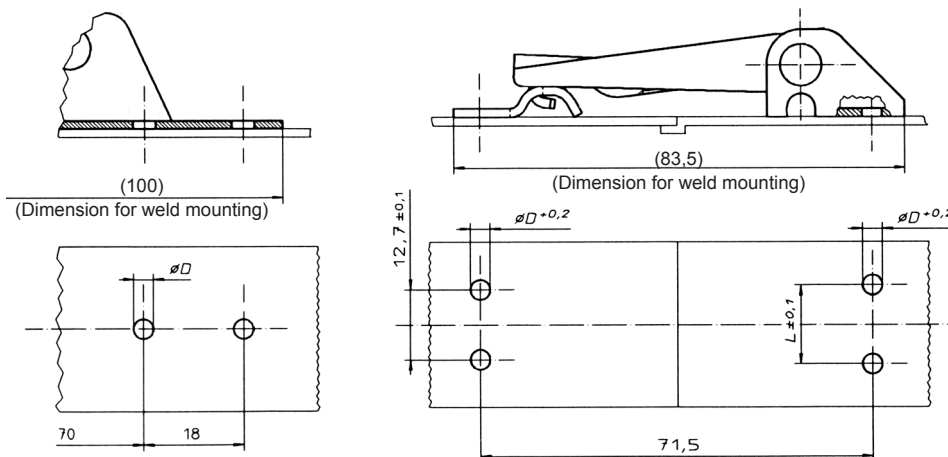

V951L02-
V951L04-
V951L01-*

V951L50-*

V951L05-

Select diameter D and distance L in accordance with the strike and tension latch style.

Dimensions

Concealed-base tension latch / closed strike

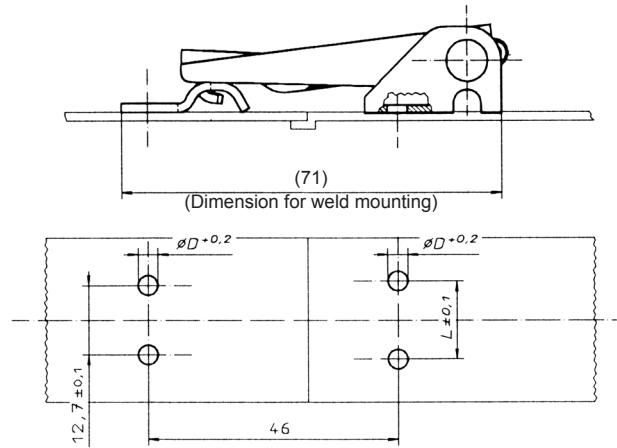

V951L03-*

V951L50-*

Select diameter D and distance L in accordance with the strike and tension latch style.

Open-base tension latch / corner-mounting strike

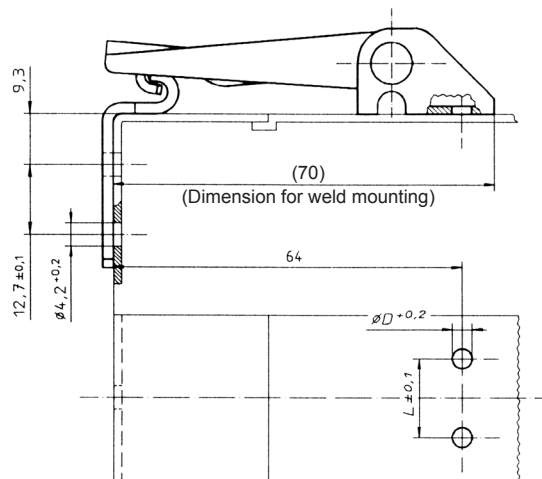

V951L02-*

V951L04-*

V951L01-*

V951L52-*

Select diameter D and distance L in accordance with the strike and tension latch style.

Concealed-base tension latch / corner-mounting strike

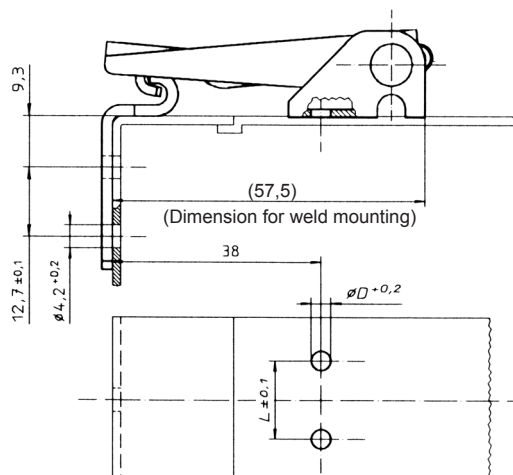

V951L03-*

V951L52-*

Select diameter D and distance L in accordance with the strike and tension latch style.

Dimensions

Open-base tension latch / wide strike

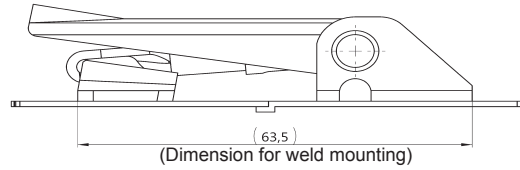

V951L01-*
V951L02-*
V951L04-*

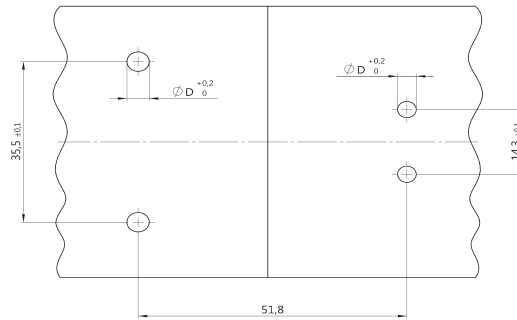

V51L59-*

Select diameter D and distance L in accordance with the strike and tension latch style.

Concealed-base tension latch / wide strike

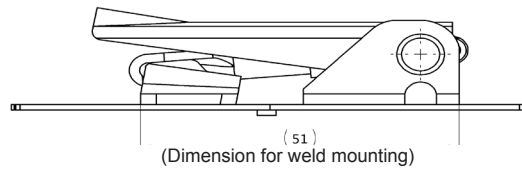

V951L03-*

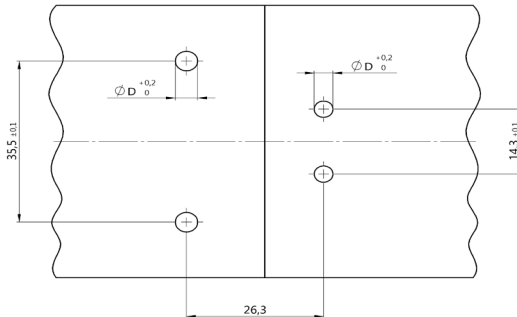

V951L59-*

Select diameter D and distance L in accordance with the strike and tension latch style.

Max. tensile strength 3.600 N, working load max. 2.700 N, see footnotes.
Adjustable drawhook
Available with secondary lock and hasp

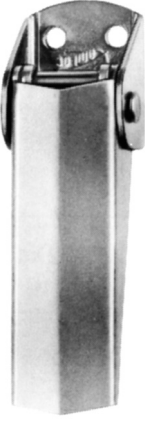
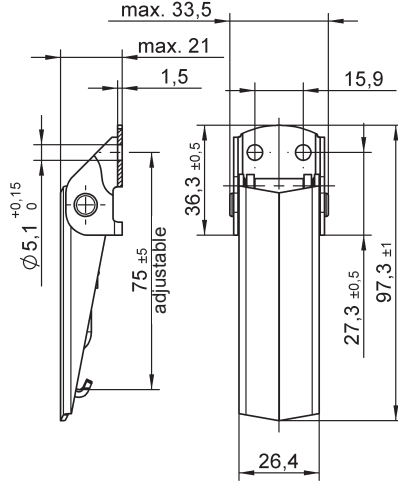
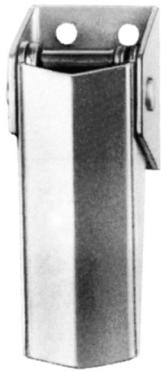
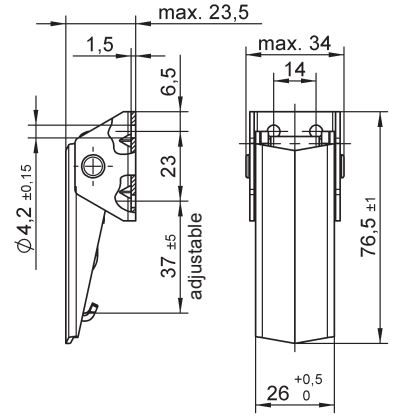
Style	Dimensions	Materials / Finish	Mounting Type ¹⁾	D	Part No.
Open base 		Steel / zinc-plated, CrVI-free, clear passivation ²⁾	N	5,1	V917L01-1-1AG
		Stainless steel ³⁾	N	5,1	V917L01-1-1BP
High base 		Steel / zinc-plated, CrVI-free, clear passivation ²⁾	N	4,2	V17L12-1-1AA

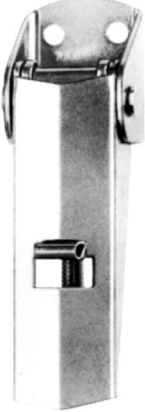
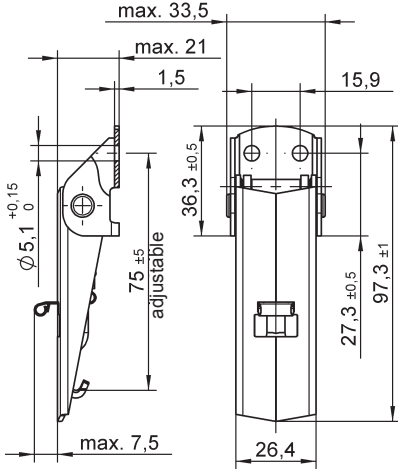
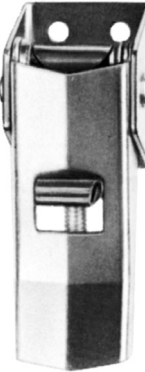
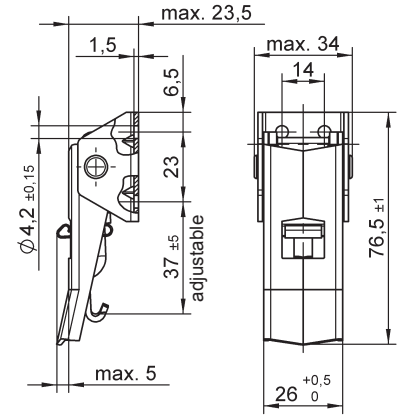
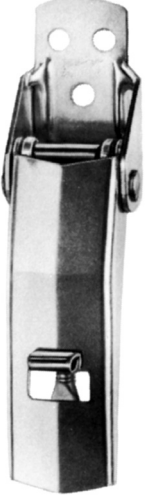
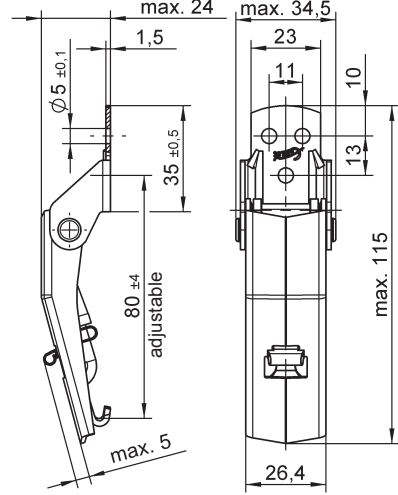

- ¹⁾ Mounting type: N = With hole for riveting or screw fixing
S = Without holes, for welding
- ²⁾ Max. tensile strength: 3.200 N with V917L11-1- *AG strike, working load 2.200 N.
2.200 N with V951L50-1- *AGV strike, working load 1.500 N.
- ³⁾ Max. tensile strength: 3.600 N with V951L50-1- *BP strike, working load 2.700 N.
max. 2.300 N with V917L11-1-1BP strike, working load 1.550 N.

Style	Dimensions	Materials / Finish	Mounting Type ¹⁾	D	Part No.
Secondary lock, open base 		Steel / zinc-plated, CrVI-free, clear passivation ²⁾	N	5,1	V917L01-1X1AG
		Stainless steel ³⁾	N	5,1	V917L01-1X1BP
		Stainless steel ³⁾	S	-	V917L01-1X2BP
		Stainless steel V4A ³⁾	N	5,1	V917L01-1X1CP
		Stainless steel V4A ³⁾	S	-	V917L01-1X2CP
Secondary lock, high base 		Steel / zinc-plated, CrVI-free, clear passivation ²⁾	N	4,2	V17L12-2X1AA
Secondary lock, for curved surfaces (R min = 125 mm) 		Steel / zinc-plated, CrVI-free, clear passivation ²⁾	N	5,0	1449L02-1X1AG
		Stainless steel ³⁾	N	5,0	1449L02-1X1BP

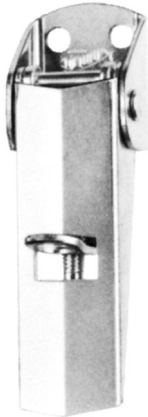
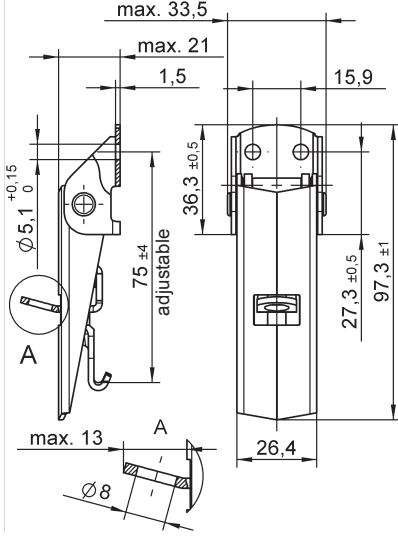
For footnotes refer to page G-1.

Style	Dimensions	Materials / Finish	Mounting Type ¹⁾	D	Part No.
<p>Open base, with hasp</p> 		Steel / zinc-plated, CrVI-free, clear passivation ²	N	5,1	V917L01-1Y1AG

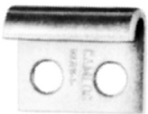
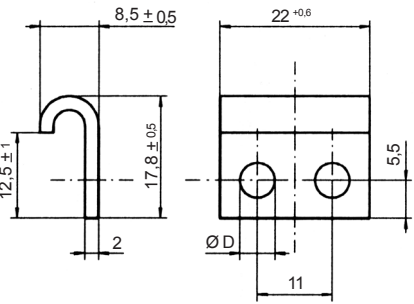
Strikes

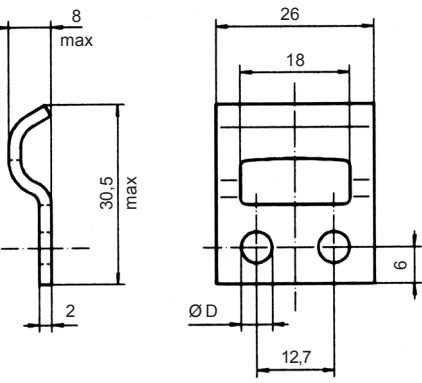
Style	Dimensions	Materials / Finish	Mounting Type ¹⁾	D	Part No.
<p>Open</p> 		Steel / zinc-plated, CrVI-free, clear passivation	N	5,1	V917L11-1-1AG
		Steel / zinc-plated, CrVI-free, clear passivation	N	4,2	V917L11-1-3AG
		Stainless steel	N	5,1	V917L11-1-1BP
<p>Closed</p> 		Steel / zinc-plated, CrVI-free, clear passivation	N	4,2	V951L50-1AGV
		Steel / zinc-plated, CrVI-free, clear passivation	N	5,1	V951L50-5AGV
		Stainless steel	N	4,2	V951L50-1BP
		Stainless steel	S	-	V951L50-3BP

For footnotes refer to page G-1.

Dimensions

Open-base tension latch / open strike

Type	L2	L2 min.	L2 max.
1-1	98	-10,5	+3,5
1Y1		-5,5	+3,5
1X1		-4,5	+2,5

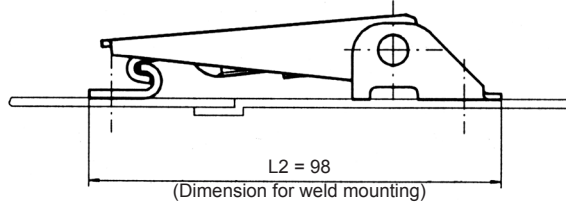

V917L01-*

V917L11-*

Type	L1	L1 min.	L1 max.
1-1	82	-9	+5
1Y1		-4	+5
1X1		-3	+4

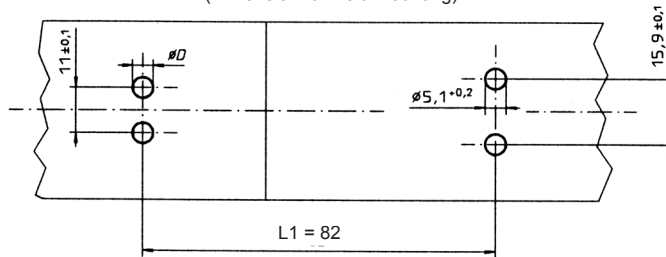

Select diameter D in accordance with the strike style.

Open-base tension latch / closed strike

Type	L2	L2 min.	L2 max.
1-1	105	-9	+5
1Y1		-5	+5
1X1		-4	+3

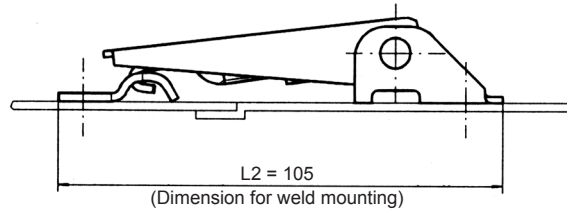

V917L01-*

V951L50-*

Type	L1	L1 min.	L1 max.
1-1	90	-9	+5
1Y1		-5	+5
1X1		-4	+3

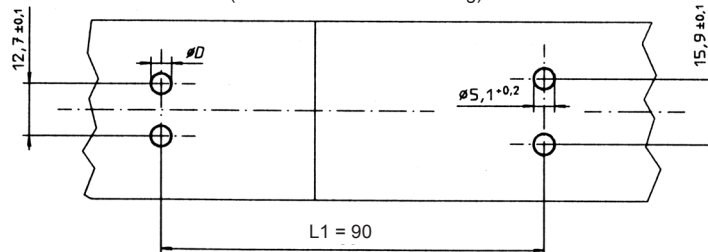

Select diameter D in accordance with the strike style.

Tension latch for curved surfaces

Type	L	L min.	L max.
1X1	101	-8	-

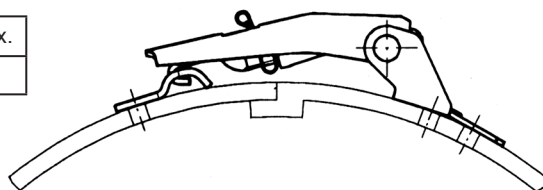

1449L02-*

V951L50-*

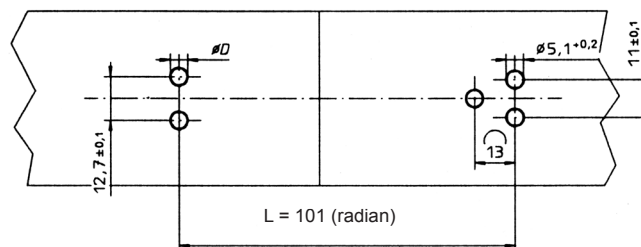

Select diameter D in accordance with the strike style.

Dimensions

High-base tension latch / open strike

Type	L	L min.	L max.
2X1	66	-4	+6

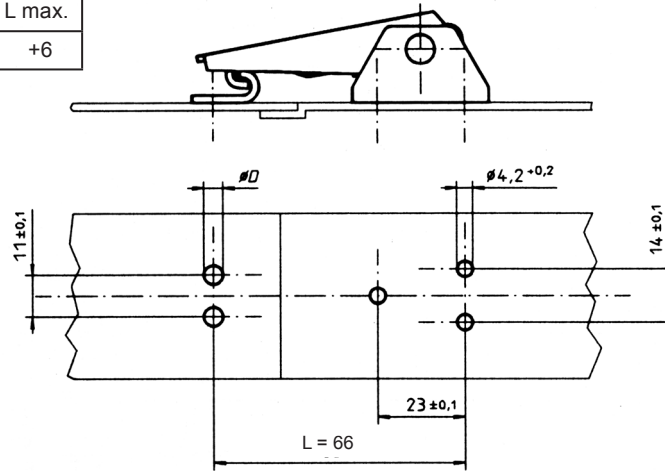

V17L12-*

V917L11-*

Select diameter D in accordance with the strike style.

Max. tensile strength 6.000 N, working load max. 4.200 N, see footnotes.

Adjustable drawhook

Available with secondary lock, hasp and lift spring

Style	Dimensions	Materials / Finish	Mounting Type ¹⁾	D	Part No.
		Steel / zinc-plated, CrVI-free, clear passivation ²⁾	N	5,1	V18L01-1-1AGV
		Stainless steel ³⁾	N	5,1	V18L01-1-1BP
		Stainless steel ³⁾	S	-	V18L01-1-2BP
With secondary lock 		Steel / zinc-plated, CrVI-free, clear passivation ²⁾	N	5,1	V18L01-1X1AGV
		Stainless steel ³⁾	N	5,1	V18L01-1X1BP
		Stainless steel ³⁾	S	-	V18L01-1X2BP

¹⁾ Mounting type: N = With hole for riveting or screw fixing

S = Without holes, for welding

²⁾ Max. tensile strength: 6.000 N with V18L13-1-1AA strike, working load 4.200 N.

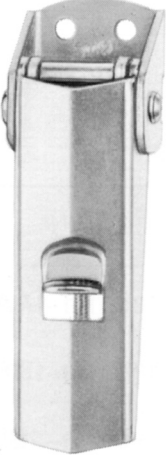
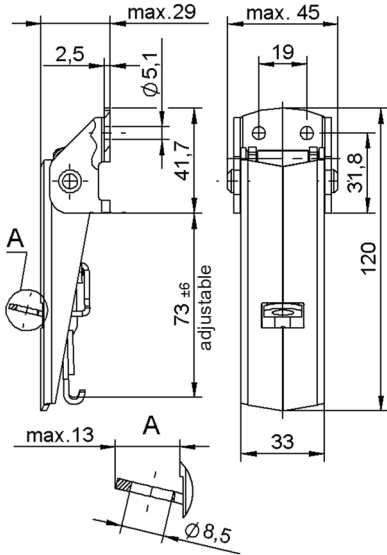

³⁾ Max. tensile strength: 4.600 N with V18L13-1-*BF or 1449L07-1BP strike, working load 3.100 N.

Style	Dimensions	Materials / Finish	Mounting Type ¹⁾	D	Part No.
<p>Hasp</p> 		Steel / zinc-plated, CrVI-free, clear passivation ²⁾	N	5,1	V18L01-1Y1AGV

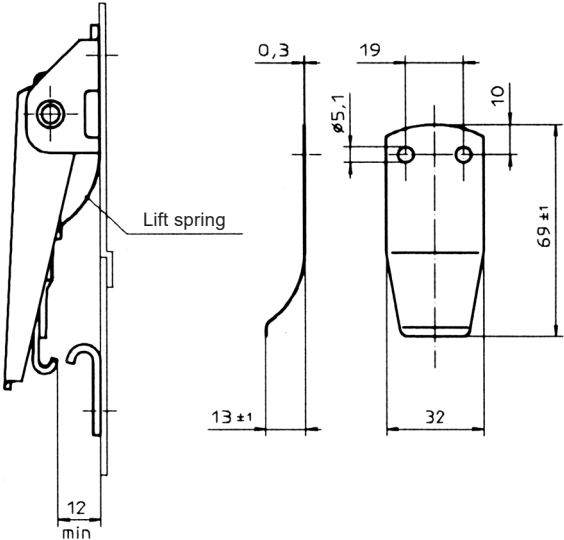
Accessories

Dimensions	Materials / Finish	Mounting Type ¹⁾	D	Part No.
<p>Lift spring</p> 	Stainless steel	N	5,1	V18L45-1BP

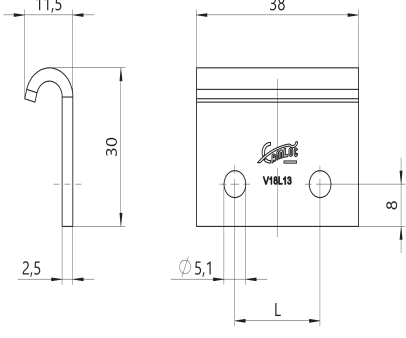
For footnotes refer to page H-1.

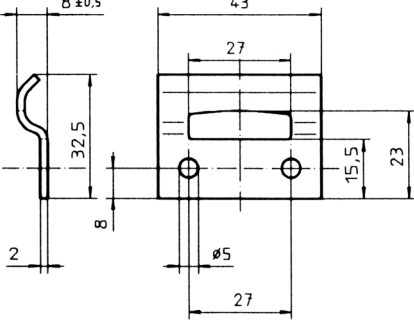
Style	Dimensions	Materials / Finish	L	Mounting Type ¹⁾	D	Part No.
Open 		Steel / zinc-plated, iridescent passivated and sealed	22	N	5,1	V18L13-1-1AGV
		Steel / zinc-plated, iridescent passivated and sealed	19	N	5,1	V18L13-1-3AGV
		Stainless steel	22	N	5,1	V18L13-1-1BP
		Stainless steel	-	S	-	V18L13-1-2BP
Closed 		Stainless steel		N	5,0	1449L07-1BP

For footnotes refer to page H-1.

Dimensions

Tension latch / open strike

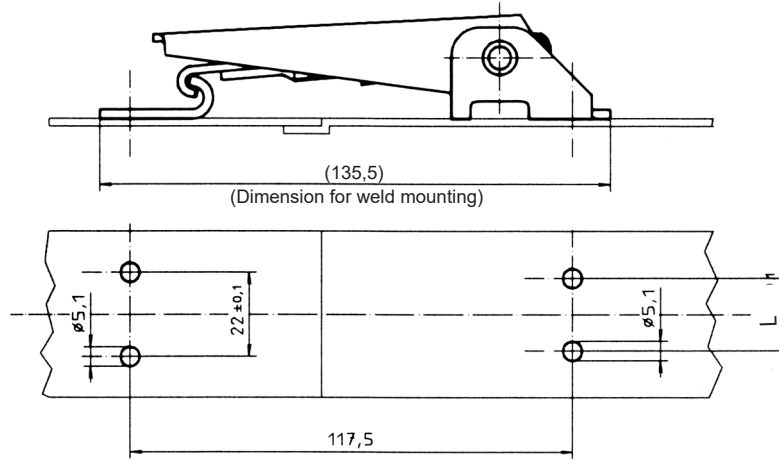

V18L01-*

V18L13-*

Tension latch / closed strike

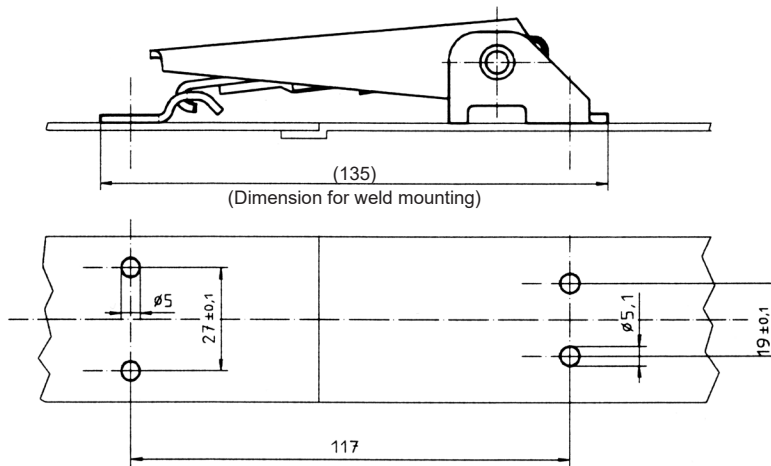

V18L01-*

1449L07-*

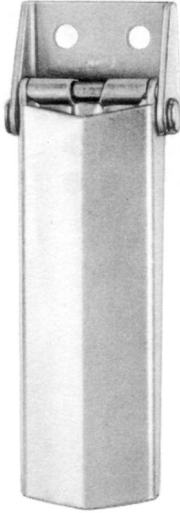
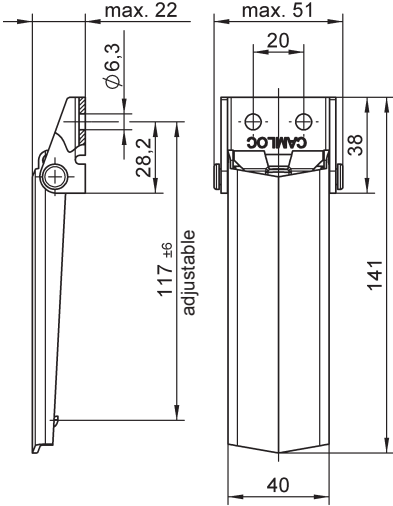

Max. tensile strength 4.500 N, working load 3.000 N.
Adjustable drawhook

Style	Dimensions	Materials / Finish	Mounting Type ¹⁾	D	Part No.
		Steel / zinc-plated, CrVI-free, clear passivation	N	6,3	V46L38-1-6AGV
		Steel / zinc-plated, CrVI-free, clear passivation	S	-	V46L38-1-1AGV

Strike

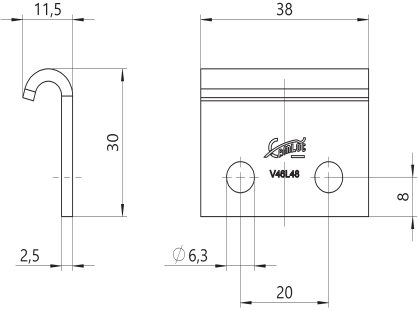
Style	Dimensions	Materials / Finish	Mounting Type ¹⁾	D	Part No.
		Steel / zinc-plated, iridescent passivated and sealed	N	6,3	V46L48-1-1AGV

¹⁾ Mounting type: N = With hole for riveting or screw fixing
S = Without holes, for welding

Dimensions

Tension latch open base / open strike

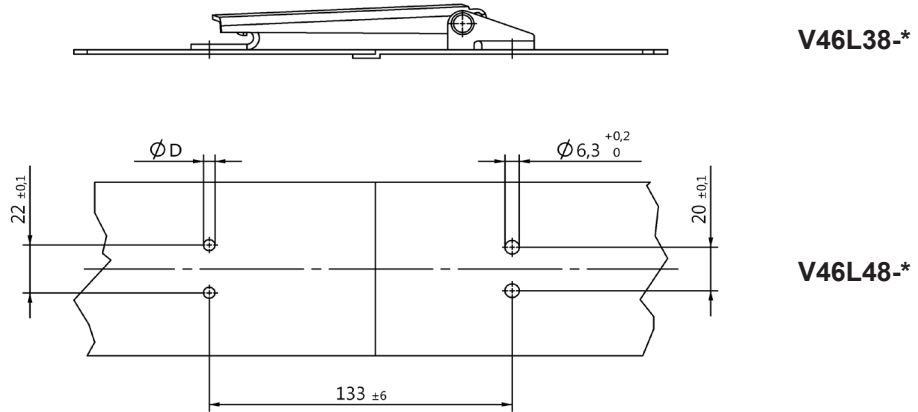

Part No.	Page	Part No.	Page	Part No.	Page
1429L02-1-1AG	E1	V917L01-1X2CP	G2	V951L50-5AGV	G3
1429L02-1-1BP	E1	V917L11-1-1AG	G3	V951L52-1AGV	F4
1429L02-1X1AG	E2	V917L11-1-3AG	G3	V951L52-1BP	F4
1429L02-1X1BP	E2	V917L11-1-1BP	G3	V951L61-4BP	F5
1429L02-2-1AG	E1	V934L01-1-1AGV	B1	V951L61-5BP	F5
1429L02-2-1BP	E1	V934L01-1X1AGV	B1	V951L7-1AD	F4
1429L02-2X1AG	E3	V934L02-1AGV	B1	V951L7-1AGV	F4
1429L02-2X1BP	E3	V934L01-1-1BP	B1	V951L7-1BP	F4
1429L02-3-1AG	E2	V934L01-1X1BP	B1	V951L7-2AZ	F4
1429L02-3-1BP	E2	V934L02-1BP	B1	V951L7-2BP	F4
1429L02-3X1AG	E3	V95H07-1-1BP	C1	V951L7-5AGV	F4
1429L02-3X1BP	E3	V95L07-1-1BC	C1	V951L7-5BP	F4
1429L8-1AG	E4	V95L15-1BD	C1	V96H01-1-1A0	D1
1429L8-1BP	E4	V951L01-1Y2AGV	F3	V96L01-1-1AG	D1
1429L9-1AG	E4	V951L01-1Y5AGV	F3	V96L01-1-1A0	D1
1429L9-1BP	E4	V951L02-1-1AD	F1	V96H01-1-2A0	D1
1449L02-1X1AG	G2	V951L02-1-1AGV	F1	V96L01-1-2AG	D1
1449L02-1X1BP	G2	V951L02-1-1BP	F1	V96L01-1-2A0	D1
1449L07-1BP	H3	V951L02-1-2AGV	F1		
V17L12-1-1AA	G1	V951L02-1-2BP	F1		
V17L12-2X1AA	G2	V951L02-1-5AGV	F1		
V18L01-1-1AGV	H1	V951L02-1-5BP	F1		
V18L01-1-1BP	H1	V951L03-1-1AD	F1		
V18L01-1-2BP	H1	V951L03-1-1AGV	F1		
V18L01-1X1AGV	H1	V951L03-1-1BP	F1		
V18L01-1X1BP	H1	V951L03-1-5AGV	F1		
V18L01-1X2BP	H1	V951L03-1-5BP	F1		
V18L01-1Y1AGV	H2	V951L03-1X1AD	F2		
V18L13-1-1AGV	H3	V951L03-1X1BP	F2		
V18L13-1-1BP	H3	V951L03-1X5AGV	F2		
V18L13-1-2BP	H3	V951L03-1X5BP	F2		
V18L13-1-3AGV	H3	V951L04-1X1AD	F2		
V18L45-1BP	H2	V951L04-1X1AGV	F2		
V46L38-1-6AGV	I1	V951L04-1X1BP	F2		
V46L38-1-1AGV	I1	V951L04-1X2BP	F2		
V46L48-1-1AGV	I1	V951L04-1X5AGV	F2		
V51L59-1ASNV	F5	V951L04-1X5BP	F2		
V917L01-1-1AG	G1	V951L05-1X1AGV	F3		
V917L01-1-1BP	G1	V951L05-1X1BP	F3		
V917L01-1X1AG	G2	V951L50-1AGV	F4,G3		
V917L01-1X1BP	G2	V951L50-1BP	F4,G3		
V917L01-1X2BP	G2	V951L50-2BP	F4		
V917L01-1X1CP	G2	V951L50-3BP	F4,G3		

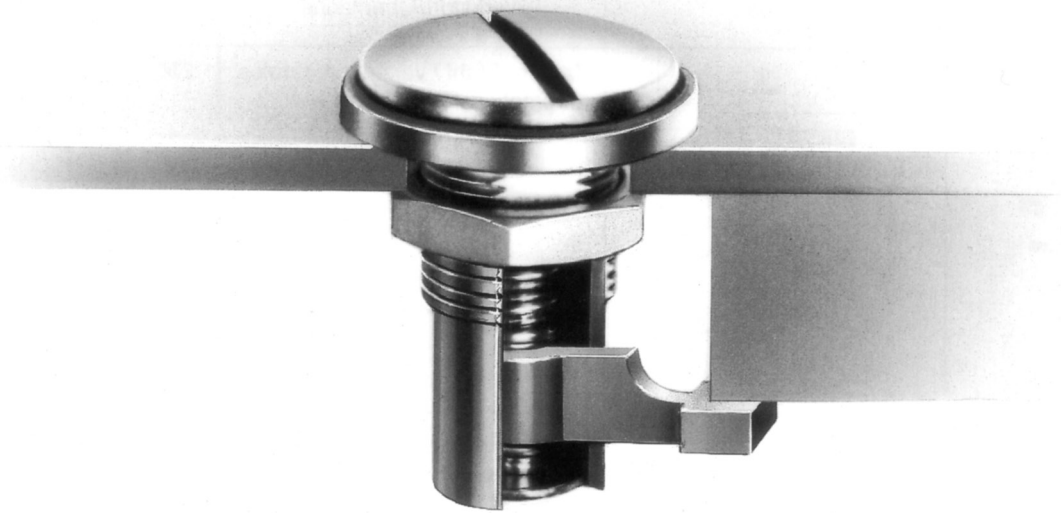

Page

General Information A-2

Specials

V964L Series B-1 - B-2

V965L Series C-1 - C-2

2939L Series D-1

2812L Series E-1 - E-6

52F Series F-1

VKM Series G-1 - G-2

Index



electrical cabinets



laboratory equipment



machine construction



agriculture



construction



solar



truck



electronic equipment



lighting interior



mould making



automotive/ racing



rail



trailer



wind

The Camloc brand was established in 1937. Since that time our fastening systems have been successfully integrated into numerous applications within many different industries.

Our customers benefit from our more than 80 years of fastening experience.

We provide local support for innovative, high quality fastening systems supplied globally to the strictest environmental and working conditions.

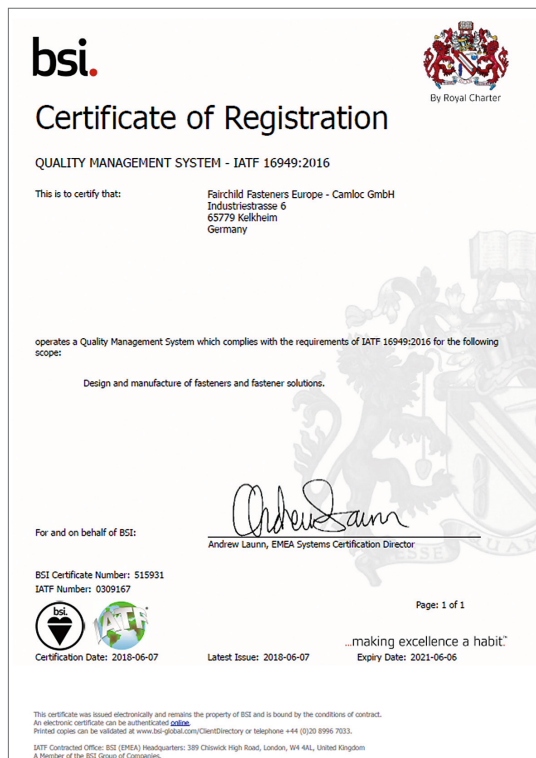

IATF 16949:2016

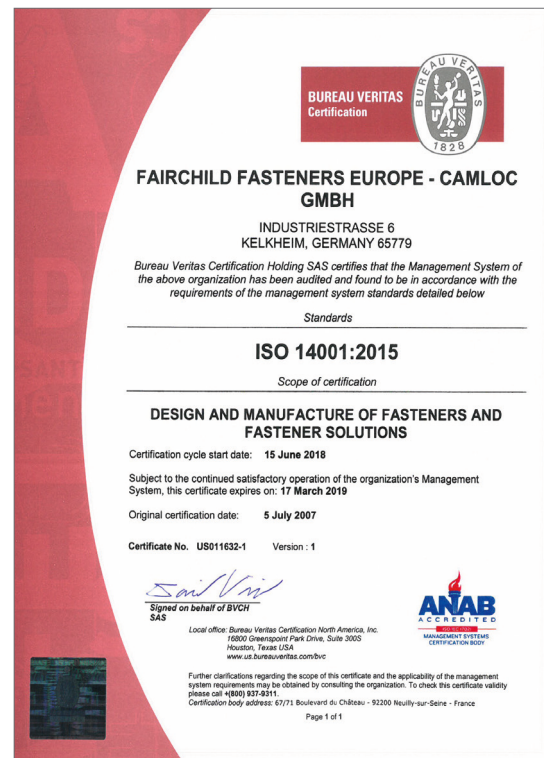

ISO 14001:2015

Your Howmet Fastening Systems team

Disclaimer:

Parts listed are subject to technical changes. All dimensions in mm. All information is correct to the best of our knowledge at the time of printing. No liability for disadvantages caused by printing errors or false application.

Features

- Wide grip range (total thickness G up to 15 mm).
- Suitable for a large range of applications.
- Easy installation with single-hole mounting.
- Either tool-operated (slotted recess head) or hand-operated (fixed wing head).
- Clockwise locking 3/4 turn maximum.

Part no. example

Pawl Latches, slotted recess head, with decorative washer.

V964L 01 -1 -2AG

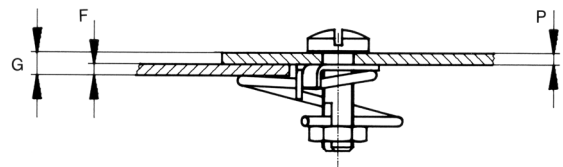
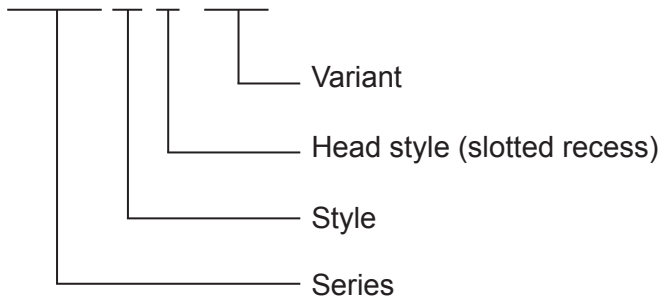

$$G = P + F \text{ (see page B-2)}$$

Style	Dimensions	Materials / Finish	°C	Part No.
Slotted Recess Head 		Stud: Steel / zinc-plated CrVI-free, clear passivation Spring: Stainless steel	120	V964L01-1-1AG
Slotted Recess Head with Decorative Washer 		Stud: Steel / zinc-plated CrVI-free, clear passivation Spring: Stainless steel	120	V964L01-1-2AG
Fixed Wing Handle Plastic 		Stud: Steel / zinc-plated CrVI-free, clear passivation Spring: Stainless steel Wing: Plastic (POM) black	-40 up to +100	V964L01-2-1AG

Installation Dimensions

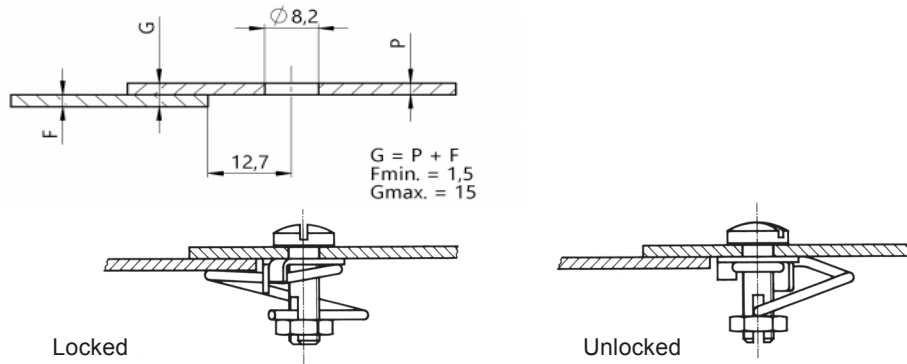



Features

- Variable grip fastener. Available in two grip ranges from 1,0 mm to 18,8 mm.
- Tool or hand operated head styles available.
- Single hole mounting - low installation cost.
- Clockwise locking as standard.
- Counterclockwise locking fasteners upon request.

Part no. example

Pawl Latches, Flat head.
Grip range 1,0 mm - 12,2 mm.

V965L 23 -1 R1AG

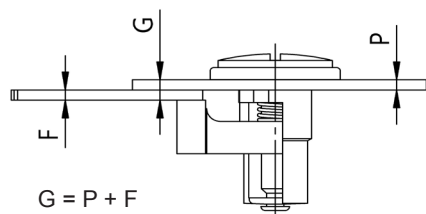
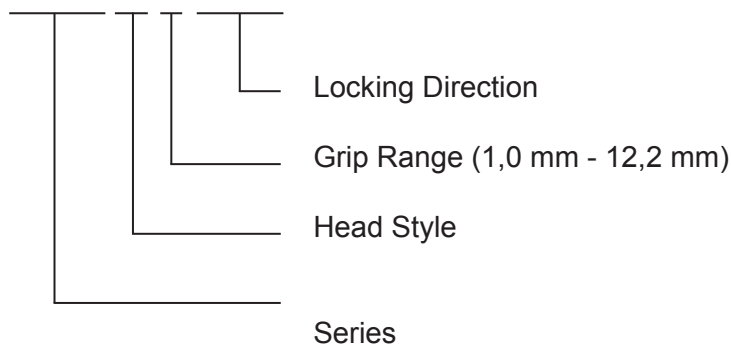





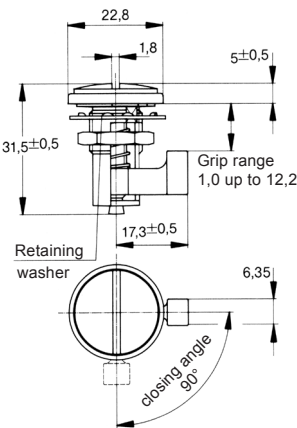

$$G = P + F$$

$$P_{min} = 0,5mm$$

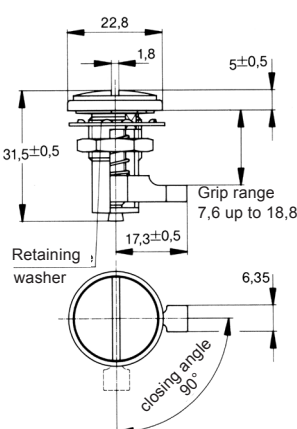
$$P_{max} = 0,5mm$$

For G = 7,6mm to 18,8mm applies $P+F \geq 7,6mm$

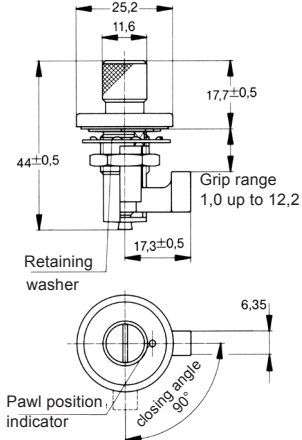
Style	Dimensions	Materials / Finish	°C	Part No.
Flat Head Grip Range 1,0 up to 12,2 	 <p>Grip range 1,0 up to 12,2</p>	Steel / zinc-plated CrVI-free, clear passivation	-40 up to +100	V965L23-1R1AG
Flat Head Grip Range 7,6 up to 18,8 	 <p>Grip range 7,6 up to 18,8</p>	Steel / zinc-plated CrVI-free, clear passivation	-40 up to +100	V965L23-2R1AG

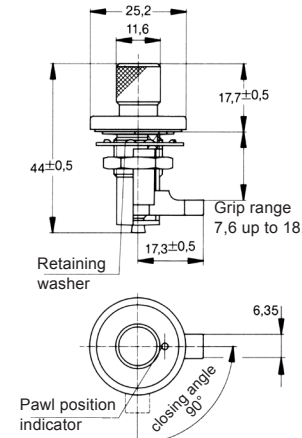
Style	Dimensions	Materials / Finish	°C	Part No.
Knurled Head Grip Range 1,0 up to 12,2 		Steel / zinc-plated CrVI-free, clear passivation	-40 up to +100	V965L1-1R1AG
Knurled Head Grip Range 7,6 up to 18,8 		Steel / zinc-plated CrVI-free, clear passivation	-40 up to +100	V965L1-2R1AG

Pawl Latches Installation Instructions

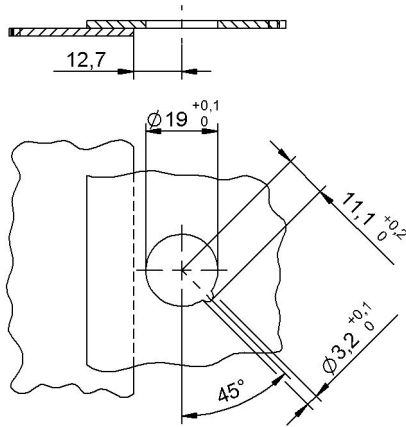
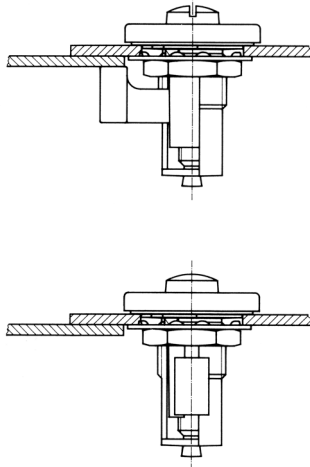
Instruction Dimensions	
<p>Clockwise locking</p> 	

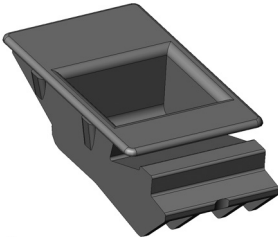
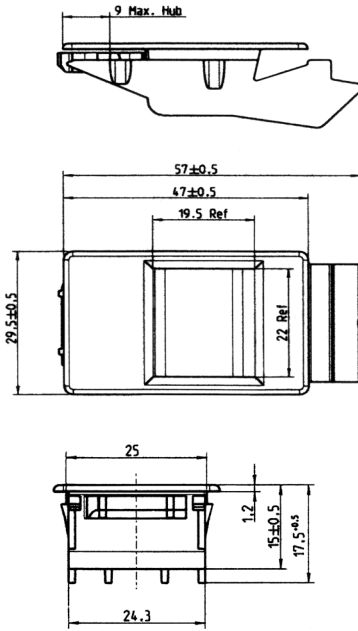

Style	Dimensions	Materials / Finish	°C	Part No.
<p>Slam latch</p> 		Plastic (POM) black	-10 up to +60	2939L01-01-1K

Installation Instructions

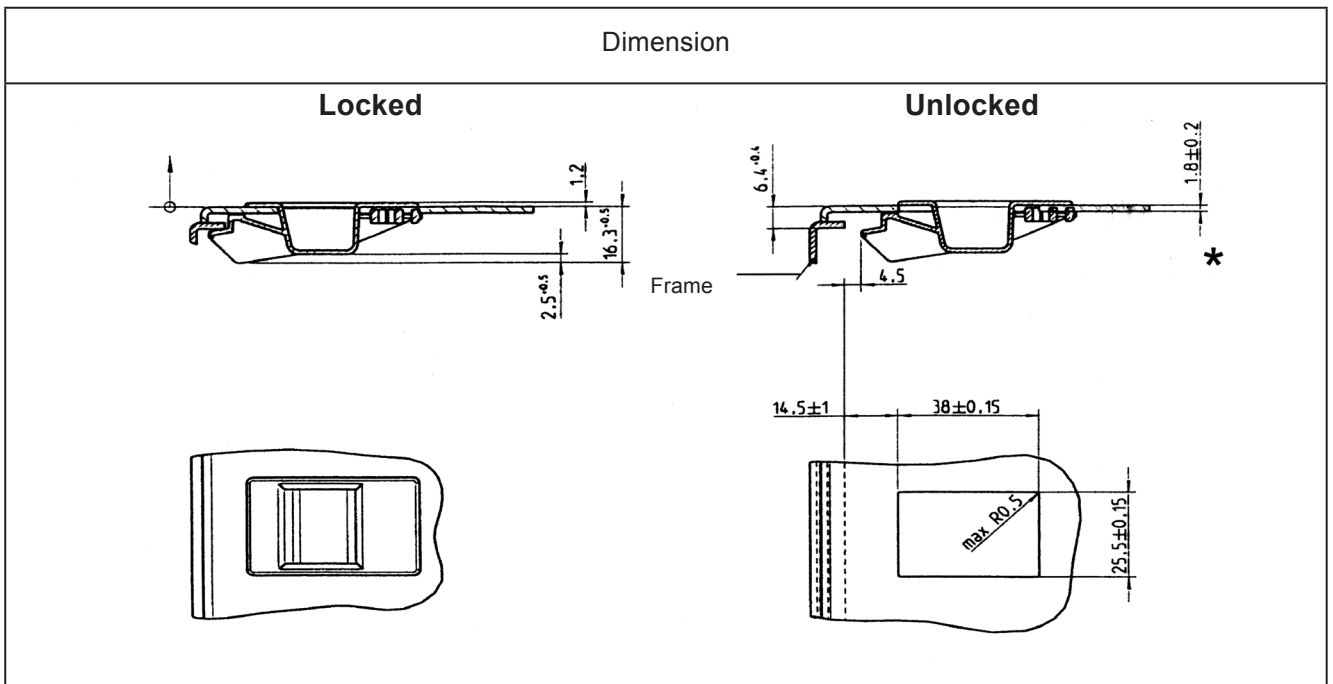

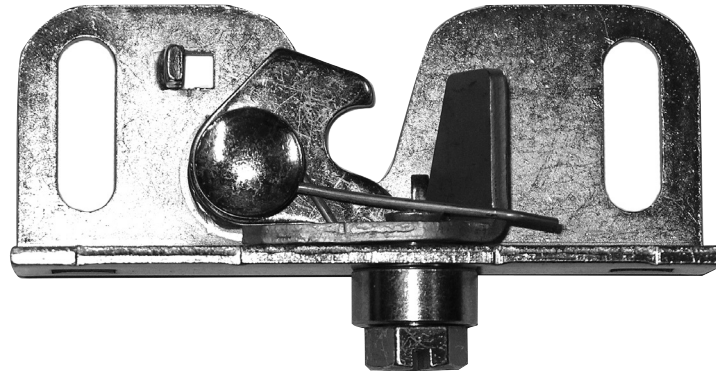

* Other panel thicknesses upon request.



Particular Features

- Robust slam latch, self locking
- Max. locking force: 230 N
- Max. tension strength: 2.400 N
- Max. torque: 40 Nm

Dimensions	Materials / Finish	Type	°C	Part No.
	 Steel / zinc-plated and yellow chromated (CrVI free) Catch: zinc flake coated	A	100	2812L03-1AF
	Steel / zinc-plated and yellow chromated (CrVI free) Catch: zinc flake coated	B	100	2812L03-2AF

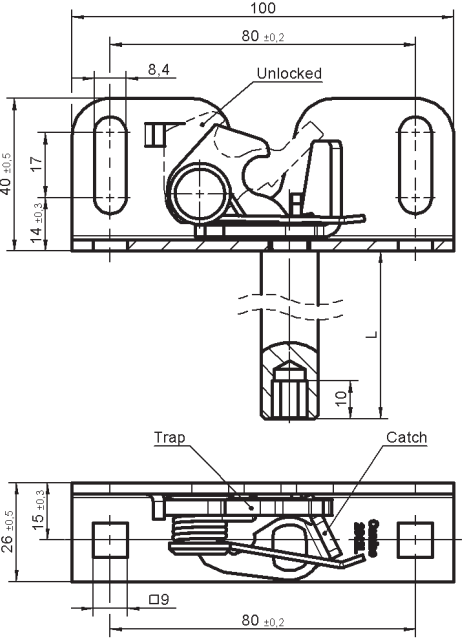
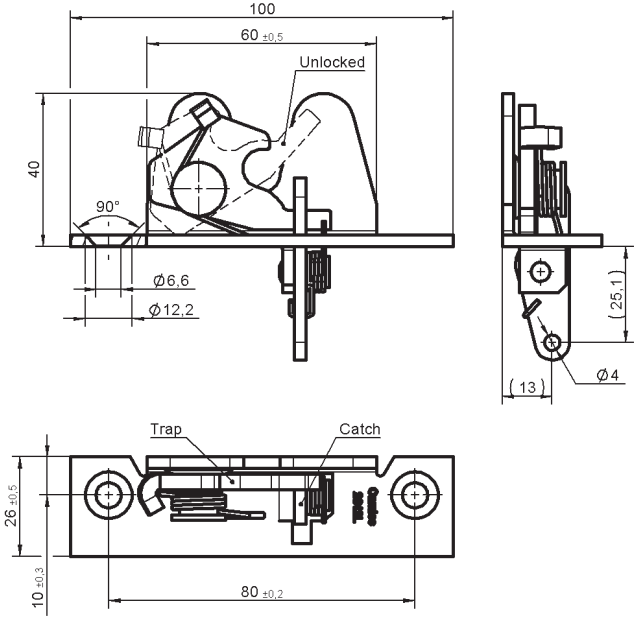
Dimensions	Materials / Finish	L	°C	Part No.
	<p>Steel / zinc-plated and yellow chromated (CrVI free) Catch: zinc flake coated</p> <p>Steel / zinc-plated and yellow chromated (CrVI free) Catch: zinc flake coated</p>	<p>110</p> <p>50</p>	<p>100</p> <p>100</p>	<p>2812L05-1AF</p> <p>2812L05-2AF</p>
	<p>Steel / zinc-plated and yellow chromated (CrVI free) Catch: zinc flake coated</p>	<p>100</p>	<p>100</p>	<p>2812L06-1AF</p>

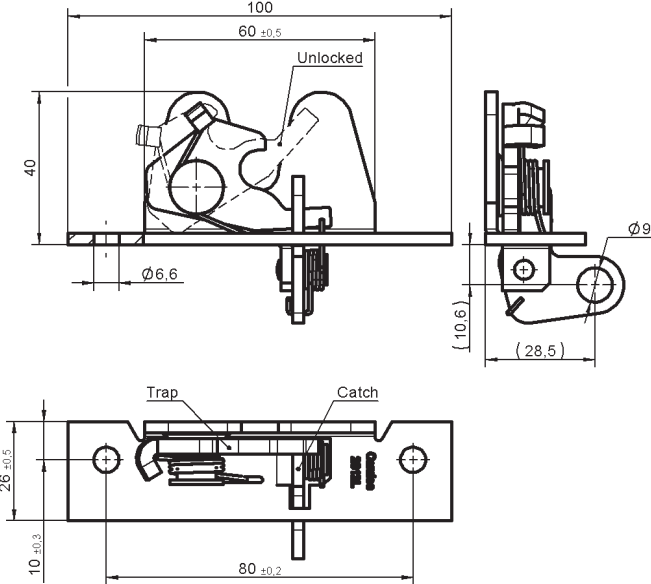
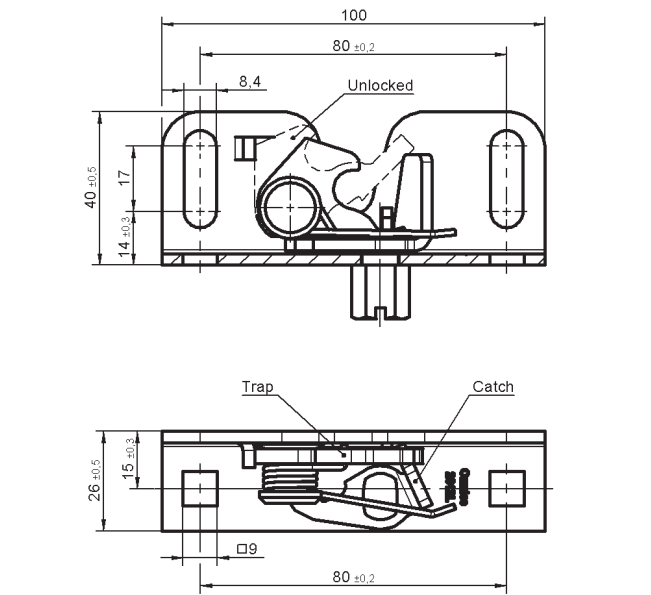
Dimensions	Materials / Finish	°C	Part No.
	<p>Steel / zinc-plated and yellow chromated (CrVI free) Catch: zinc flake coated</p>	<p>100</p>	<p>2812L07-1AF</p>
	<p>Steel / zinc-plated and yellow chromated Catch: zinc flake coated</p>	<p>100</p>	<p>2812L08-1AF</p>

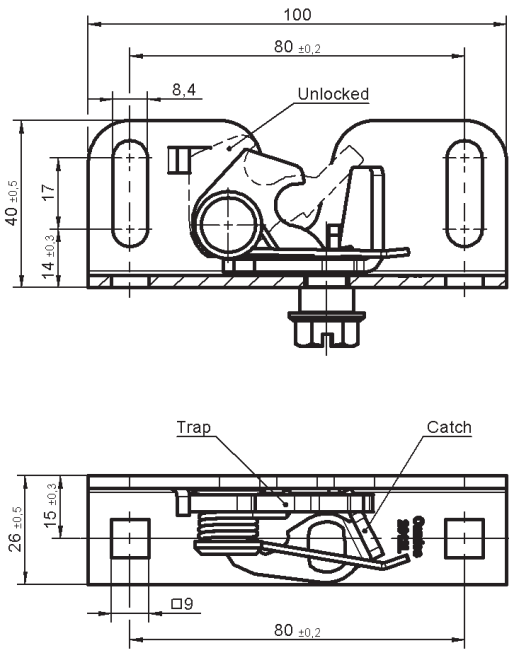
Dimensions	Materials / Finish	°C	Part No.
 <p>The drawing shows two views of the latch. The top view is a front view with dimensions: total width 100, mounting hole spacing 80 ±0.2, a distance of 8.4 from the left edge to the start of the mounting holes, and a total height of 40 ±0.5. The bottom view is a side view with dimensions: total height 26 ±0.5, mounting hole spacing 80 ±0.2, and a distance of 15 ±0.3 from the left edge to the start of the mounting holes. Labels include 'Unlocked' for the top view and 'Trap' and 'Catch' for the side view. A square symbol with the number 9 is also present in the side view.</p>	<p>Steel / zinc-plated and yellow chromated Catch: zinc flake coated</p>	<p>100</p>	<p>2812L09-1AF</p>

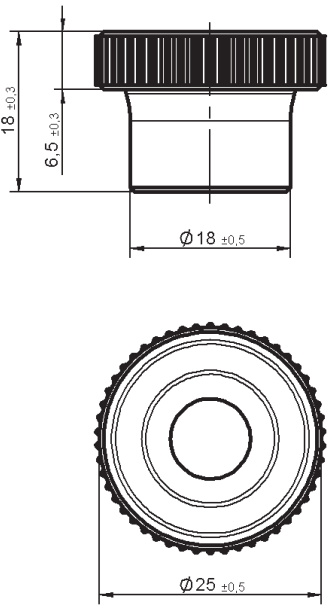
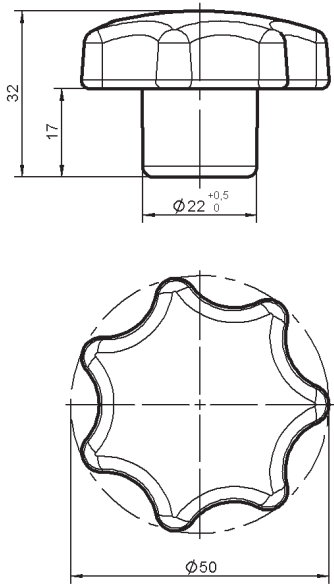
Dimensions	Materials / Finish	°C	Part No.
	<p>Plastic (POM) / black</p> <p>to be used with: 2812L03-1AF 2812L03-2AF 2812L08-1AF 2812L09-1AF</p>	<p>-25 up to +90</p>	<p>2812L80-1K</p>
	<p>Plastic (PA6) / black</p> <p>to be used with: 2812L03-1AF 2812L03-2AF 2812L08-1AF 2812L09-1AF</p>	<p>-40 up to +60</p>	<p>2812L82-1K</p>

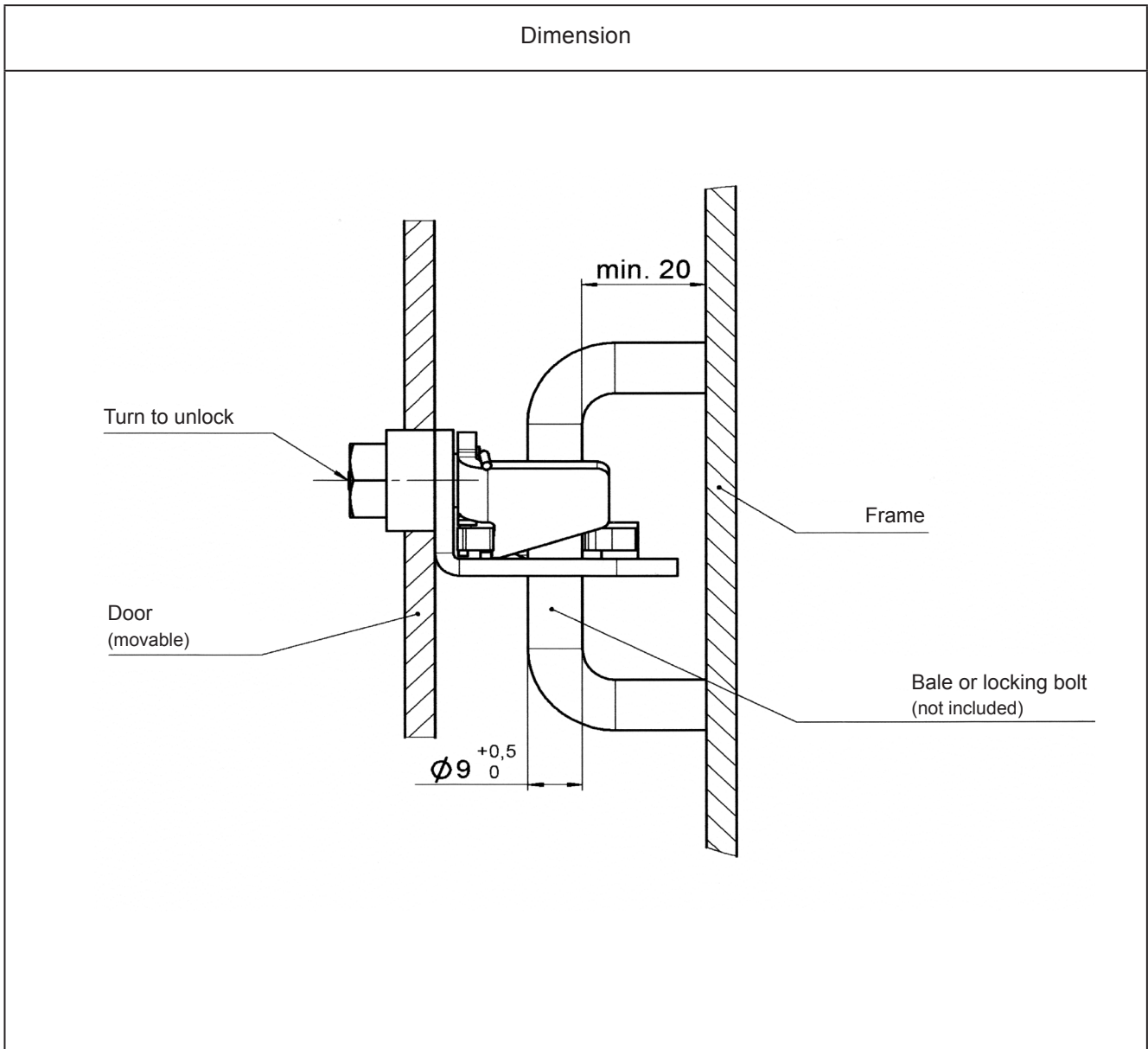

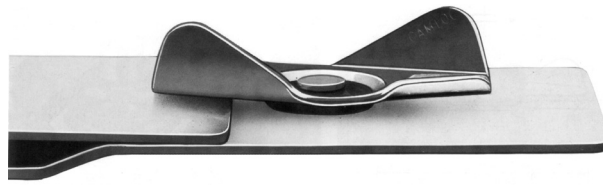

Particular Features

Simple and economic fastener for lids, etc.

Easy installation by blind riveting.

¼ Turn to lock

Secure locking on detent.

Dimensions	Materials / Finish	°C	Part No.
	Steel / zinc-plated, CrVI-free, clear passivation	100	52E02-*-1AG

Selection and Installation Instructions

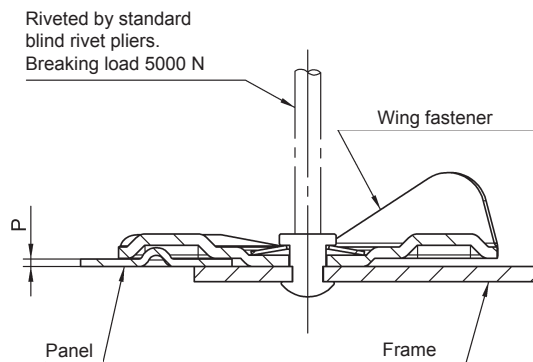
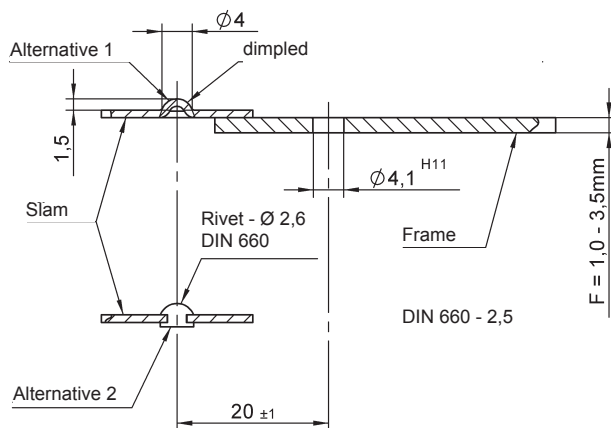

Part No.	Panel Thickness P	Height H
52E02-01-1AG	0 (flush)	0,7
52E02-02-1AG	1	1,1
52E02-03-1AG	2	1,7



Particular Features

Operation by hand installation.

Easy installation with single-hole mounting.

Absorbs shock and vibration.

Ideal for sheet metal panel applications.

Delivery: spring and clip assembled, handle packed separately.

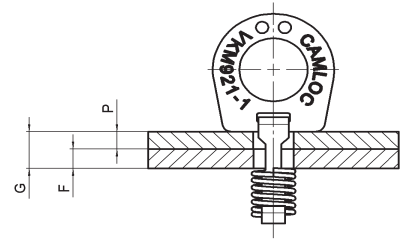

VKM1040-1AGV

VKM921-1AGV

$G = P + F$

Gmax. = 6mm

Gmin. = 1mm

$G = P + F$

Gmax. = 6,35mm

Gmin. = 1,5mm

Product	Dimensions	Materials / Finish	°C	Part No.
<p>folding handle</p>		Steel / zinc-plated, CrVI-free transparent, iricedent passivated and sealed	120	VKM921-1AGV
<p>folding handle</p>		Steel / zinc-plated, CrVI-free transparent, iricedent passivated and sealed	120	VKM1040-1AGV

Installation Instructions

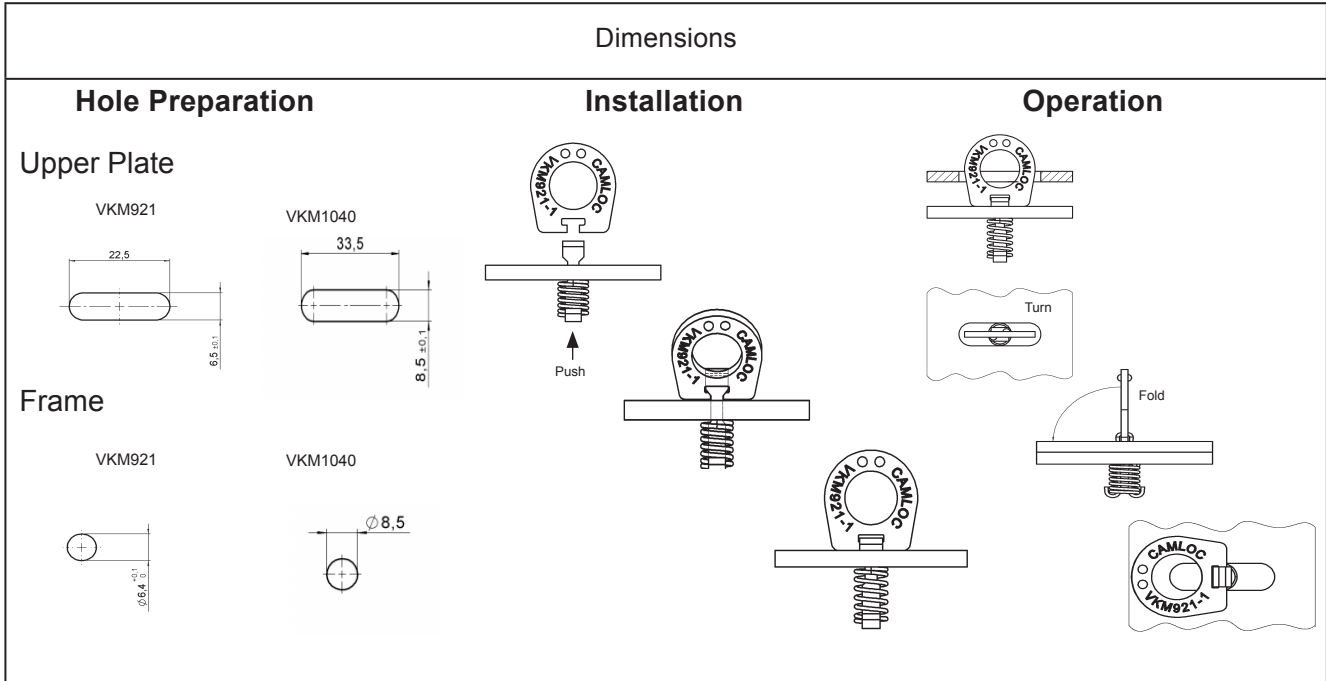

YouTube Video:



Part No.	Page
52E02-*-1AG	F1
2812L03-1AF	E1
2812L03-2AF	E1
2812L05-1AF	E2
2812L05-2AF	E2
2812L06-1AF	E2
2812L07-1AF	E3
2812L08-1AF	E3
2812L09-1AF	E4
2812L80-1K	E5
2812L82-1K	E5
2939L01-01-1K	D1
V964L01-1-1AG	B1
V964L01-1-2AG	B1
V964L01-2-1AG	B1
V965L1-1R1AG	C2
V965L1-2R1AG	C2
V965L23-1R1AG	C1
V965L23-2R1AG	C1
VKM921-1AGV	G1
VKM1040-1AGV	G1



General Information	A-2
Features of KEENSERTS [®]	A-3 - A-4
Installation Instructions	A-5
KNCM Series (miniature inserts metric)	B-1
KNM Series (lightweight inserts metric)	B-2
KNHM Series (heavy duty inserts metric)	B-3 - B-4
KNCA Series (miniature inserts imperial)	C-1
KNJ Series (lightweight inserts imperial)	C-2 - C-3
KNHJ Series (heavy duty inserts imperial)	C-4 - C-7
KNHXHJ Series (extra heavy duty inserts imperial)	C-8 - C-11
KEENSERTS [®] POWER TOOLS	D-1
Features	D-2
Technical Data and Standards	D-3
Nosepieces	D-4
Installation procedure	D-5
Available nosepieces	D-6 – D-7
KEENSERTS [®] Hand Tools KNT Series	E-1
General Informations	E-3
Installation Process	E-4
Available Tool sizes	E-5
KEENSERTS [®] EPT1 POWER TOOL	F-1
Features	F-3
Technical Data and Standards	F-4
Nosepieces	F-5
Installation procedure	F-6
Available nosepieces	F-7 – F-8

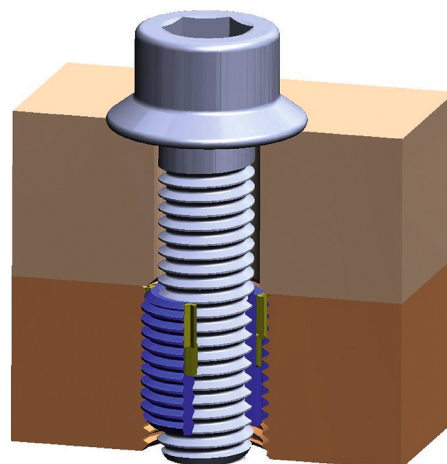

The Camloc brand was established in 1937. Since that time our fastening systems have been successfully integrated into numerous applications within many different industries.

Our customers benefit from our more than 80 years of fastening experience.

We provide local support for innovative, high quality fastening systems supplied globally to the strictest environmental and working conditions.

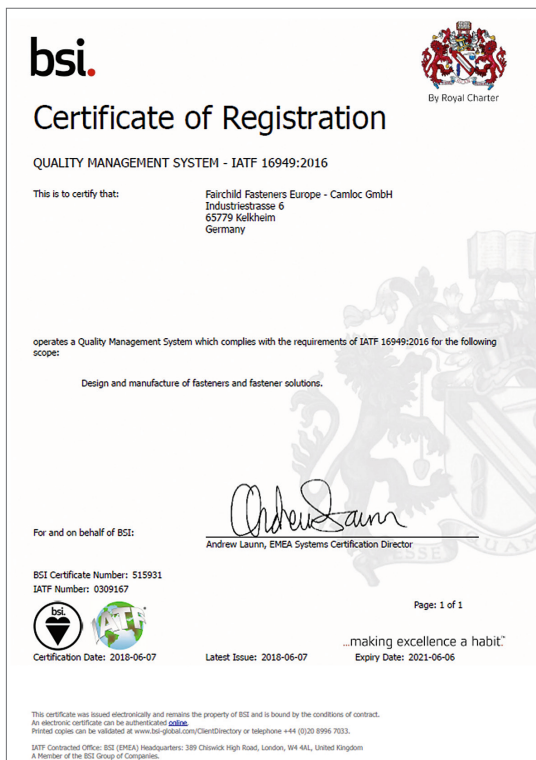

IATF 16949:2016



ISO 14001:2015

Your Howmet Fastening Systems team

Disclaimer:

Parts listed are subject to technical changes. All dimensions in mm. All information is correct to the best of our knowledge at the time of printing. No liability for disadvantages caused by printing errors or false application.

Threaded Inserts

KEENSERTS® are high strength threaded inserts made from stainless steel 1.4305 or AISI303. They are passivated according to EN 2516 or AMS 2700. Our **KEENSERTS®** standard product range contains metric and imperial thread dimensions. Specials are available upon request.

KEENSERTS® can be used in alloys, light materials, steel and cast iron to give increased thread strength in these low strength materials. They are also be used for thread repair enabling the damaged thread to be replaced with the same size thread.

KEENSERTS® Solid configuration gives a high cycle life with multiple tightening and loosening of the bolt. Locking inserts have a dry film lubrication on the surface to protect the screw from galling.

KEENSERTS® have a positive mechanical lock against rotation and vibration when kees are installed. Kees are made from stainless steel AISI302.

KEENSERTS® have 2 or 4 pre-assembled kees depending on the size of the external thread. After installation of the kees into the parent material the assembly is positively locked in place.

Pull-out-strength for **KEENSERTS®**. Calculation is as follows:

Pull-out-strength(N) = shear engagement (mm²) x ultimate shear strength of parent material (N/mm²)
Shear engagement areas are shown on the **KEENSERTS®** data sheets, only valid for full installed **KEENSERTS®**.

Click here:

[Camloc KEENSERTS® \(Youtubelink\)](#)



Part-no. example:

The part-no. for metric **KEENSERTS®** are coded as follows:

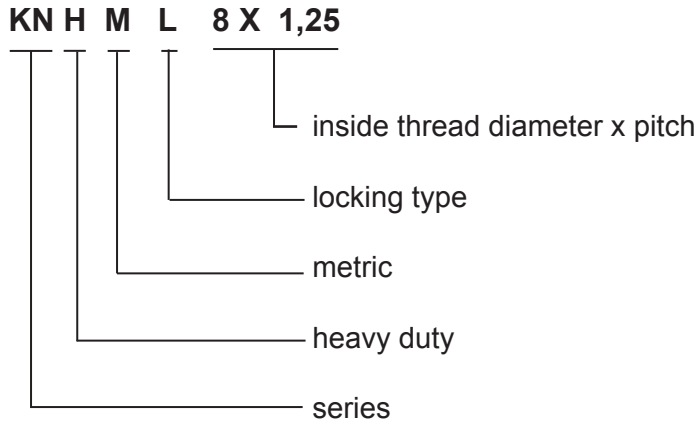

The part-no. for imperial **KEENSERTS®** are coded as follows:

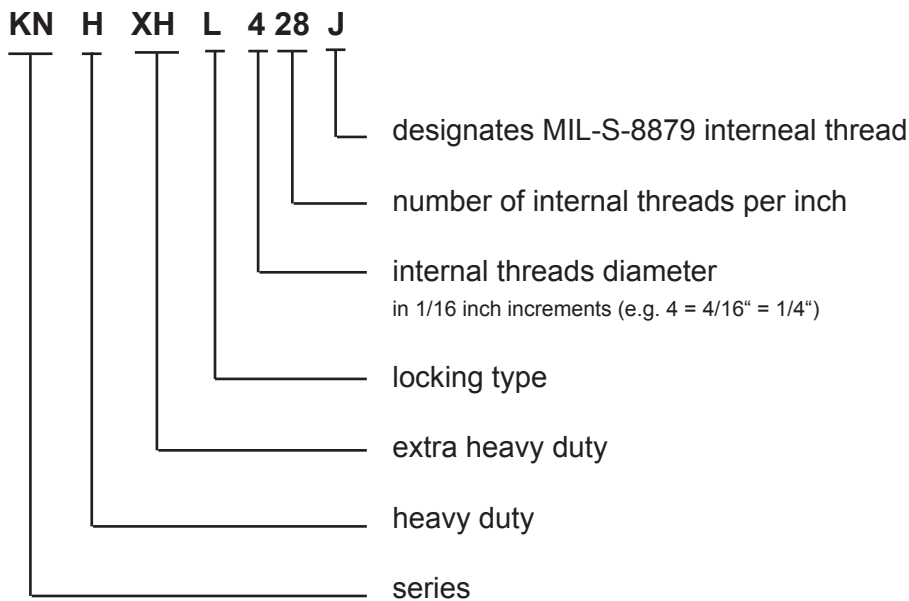

Installation:

- Drill - with standard drill
- Countersink - with cone countersink (80° - 100°)
- Thread - with standard tap
- Screw in - by hand or with installation tool
(see installation data pages B-1 to B-4)
- Lock in Place - drive the kees into place by hand
or in a press with the appropriate
installation tool

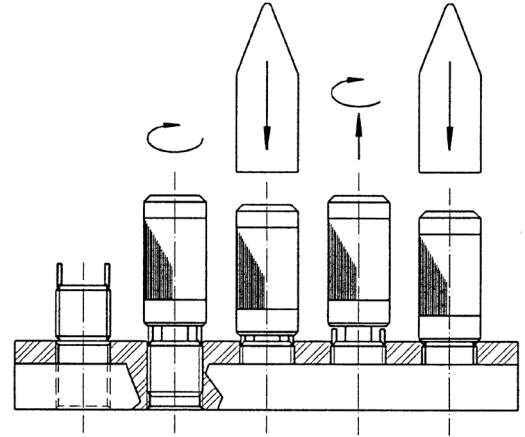

Installation depth of the **KEENSERTS®** is determined by the pre-assembled kees.
The installed depth of the **KEENSERTS®** is based on the depth of the countersink.

Installation in hard materials

For very hard materials with a hardness greater than 30 HRC or 300 Vickers it is necessary to pre-broach the slots for the kees. The first step is to mark the position of the kees on the parent material. To do this wind the **KEENSERTS®** in until the kees touch the surface of the parent material.

Mark the positions of the kees and unwind the **KEENSERTS®**.

Then line up the blades of the broaching tool with the marked positions and push it in with a hammer or under a press, remove the tool and install the **KEENSERTS®**.

In some cases it may be necessary to run the tap back down the hole to clear out any burrs. Available for external metrical thread M5 and up and external imperial thread 1/4" and up.



Removal:

1. Drilling
Dimensions see pages B1 to B4
2. Deflect kees inward and break off
3. Remove insert with E-Z out type tool
4. Insert new **KEENSERTS®** as before

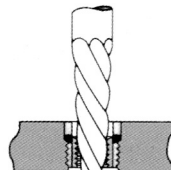
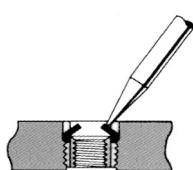
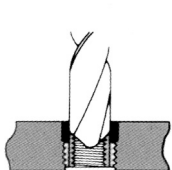

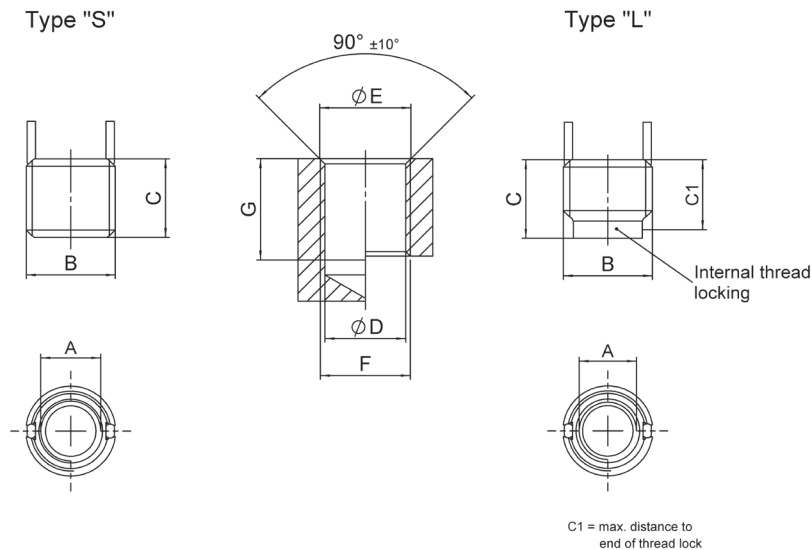

Part-no.		Dimensions				
Standard type "S"	Locking type "L"	Thread A Ø A class 5H	Thread B Ø B class 4h	Shear engagement mm ²	C ± 0,25	C1
KNCM2X0,4		M2X0,4	M4X0,7	16,5	3	2,2
	KNCML2X0,4			10,3		
KNCM2,5X0,45		M2,5X0,45	M4,5X0,75	26,5	3,8	2,7
	KNCML2,5X0,45			15,9		
KNCM3X0,5		M3X0,5	M5X0,8	33,1	4,25	3,1
	KNCML3X0,5			21,4		
KNCM4X0,7		M4X0,7	M6X0,75	58,4	5,25	4,1
	KNCML4X0,7			42,9		

Part-no.	Installation dimensions					Removal dimensions	
	Ø D modified tap drill Ø	Ø E counter- sink Ø + 0,25	Thread F		Hand installation tool part-no.	Drill	
			Ø F class 6H	G min.		Ø	Depth
KNCM2X0,4	3,4 +0,080 -0,025	4,1	M4X0,7	4,0	KRTM2-01	2,8	2,00
KNCML2X0,4							
KNCM2,5X0,45	3,9 +0,080 -0,025	4,6	M4,5X0,75	5,0	KRTM2,5-01	3,0	2,00
KNCML2,5X0,45							
KNCM3X0,5	4,4 +0,080 -0,025	5,1	M5X0,8	5,5	KRTM3-01	3,5	2,25
KNCML3X0,5							
KNCM4X0,7	5,5 +0,080 -0,025	6,1	M6X0,75	6,5	KRTM4-01	4,6	2,50
KNCML4X0,7							



Type "S"

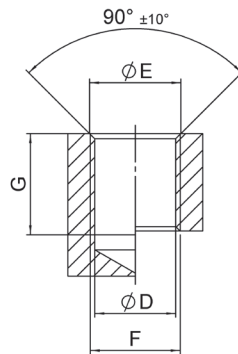
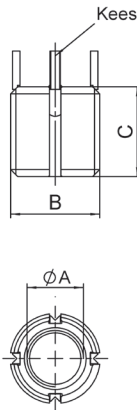

Type "L"

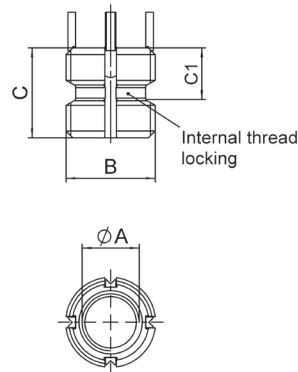

Kees:
Inserts with internal thread size of M6 and under are furnished with 2 locking kees
Inserts with internal thread size of M8 and above are furnished with 4 locking kees

C1 = max. distance to end of thread lock

Part-no.		Dimensions				
Standard type "S"	Locking type "L"	Thread A Ø A class 5H	Thread B Ø B class 4h	Shear engagement mm ²	C ± 0,30	C1
KNM5X0,8		M5X0,8	M8X1,25	104,9	8	7,6
	KNML5X0,8			83,1		
KNM6X1,0		M6X1,0	M10X1,25	177,7	10	8,2
	KNML6X1,0			152,7		
KNM8X1,25		M8X1,25	M12X1,25	266,7	12	9,5
	KNML8X1,25			242,5		
KNM10X1,5		M10X1,5	M14X1,5	341,6	14	10,0
	KNML10X1,5			316,4		
KNM12X1,75		M12X1,75	M16X1,5	470,2	16	11,2
	KNML12X1,75			441,4		

Part-no.	Installation dimensions				Hand installation tool part-no.	Removal dimensions	
	Ø D modified tap drill Ø	Ø E counter- sink Ø + 0,25	Thread F			Drill	
			Ø F class 6H	G min.		Ø	Depth
KNM5X0,8	6,90 +0,100 -0,025	8,25	M8X1,25	9,5	KRTM5-01/ KNT01-M5X0,8AU	5,5	4,00
KNML5X0,8							
KNM6X1,0	8,80 +0,100 -0,025	10,25	M10X1,25	11,5	KRTM6-01/ KNT01-M6X1,0AU	7,5	4,75
KNML6X1,0							
KNM8X1,25	10,80 +0,100 -0,025	12,25	M12X1,25	13,5	KRTM8-01/ KNT01-M8X1,25AU	9,5	4,75
KNML8X1,25							
KNM10X1,5	12,80 +0,130 -0,025	14,25	M14X1,5	15,5	KRTM10-01/ KNT01-M10X1,5AU	11,5	4,75
KNML10X1,5							
KNM12X1,75	14,75 +0,130 -0,025	16,25	M16X1,5	17,5	KRTM12-01/ KNT01- M12X1,75AU	13,5	4,75
KNML12X1,75							



Type "S"

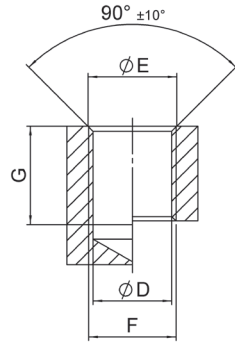
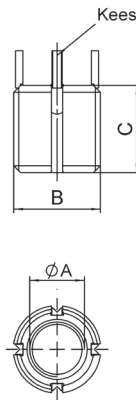

Type "L"

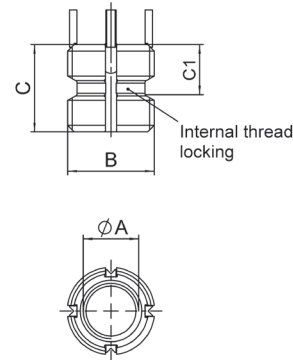

Kees:
Inserts with internal thread size of M6 and under are furnished with 2 locking kees
Inserts with internal thread size of M8 and above are furnished with 4 locking kees

C1 = max. distance to end of thread lock

Part-no.		Dimensions				
Standard type "S"	Locking type "L"	Thread A Ø A class 5H	Thread B Ø B class 4h	Shear engagement mm ²	C ± 0,30	C1
KNHM4X0,7		M4X0,7	M8X1,25	104,9	8	8,0
	KNHML4X0,7			83,1		
KNHM5X0,8		M5X0,8	M10X1,25	177,1	10	8,7
	KNHML5X0,8			152,7		
KNHM6X1,0		M6X1,0	M12X1,25	266,7	12	9,5
	KNHML6X1,0			242,5		
KNHM8X1,25		M8X1,25	M14X1,5	341,6	14	10,0
	KNHML8X1,25			316,4		
KNHM10X1,5		M10X1,5	M16X1,5	470,2	16	10,0
	KNHML10X1,5			441,4		
KNHM12X1,75		M12X1,75	M18X1,5	608,5	18	10,7
	KNHML12X1,75			561,8		

Part-no.	Installation dimensions					Removal dimensions	
	Ø D modified tap drill Ø	Ø E counter- sink Ø + 0,25	Thread F		Hand installation tool part-no.	Drill	
			Ø F class 6H	G min.		Ø	Depth
KNHM4X0,7	6,90 ^{+0,100} -0,025	8,25	M8X1,25	9,5	KRTM4-02 / KNT01-HM4X0,7AU	5,5	4,00
KNHML4X0,7							
KNHM5X0,8	8,80 ^{+0,100} -0,025	10,25	M10X1,25	12,5	KRTM5-02 / KNT01-HM5X0,8AU	7,5	4,75
KNHML5X0,8							
KNHM6X1,0	10,80 ^{+0,100} -0,025	12,25	M12X1,25	14,5	KRTM6-02 / KNT01-HM6X1,0AU	9,5	4,75
KNHML6X1,0							
KNHM8X1,25	12,80 ^{+0,130} -0,025	14,25	M14X1,5	16,5	KRTM8-02 / KNT01-HM8X1,25AU	11,5	4,75
KNHML8X1,25							
KNHM10X1,5	14,75 ^{+0,130} -0,025	16,25	M16X1,5	18,5	KRTM10-02 / KNT01-HM10X1,5AU	13,5	4,75
KNHML10X1,5							
KNHM12X1,75	16,75 ^{+0,130} -0,025	18,25	M18X1,5	20,5	KRTM12-02 / KNT01-HM12X1,75AU	15,5	4,75
KNHML12X1,75							

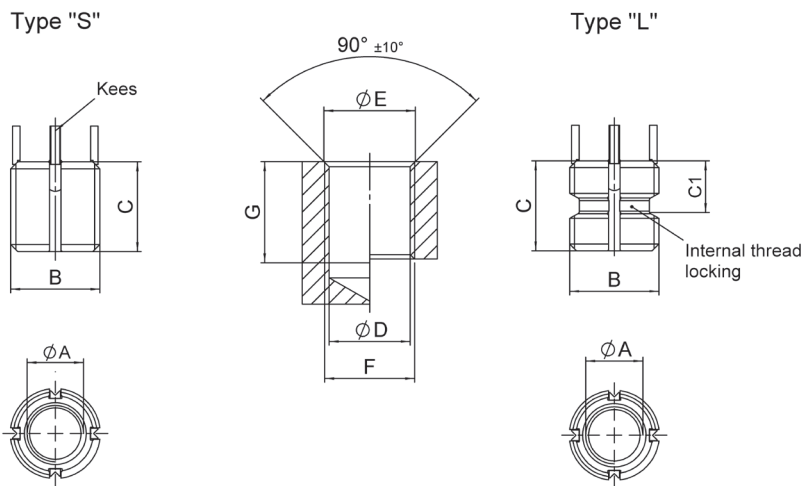

Kees:
Inserts with internal thread size of M6 and under are furnished with 2 locking kees
Inserts with internal thread size of M8 and above are furnished with 4 locking kees

C1 = max. distance to end of thread lock

Part-no.		Dimensions				
Standard type "S"	Locking type "L"	Thread A Ø A class 5H	Thread B Ø B class 4h	Shear engagement mm ²	C ± 0,30	C1
KNHM14X2,0		M14X2,0	M20X1,5	770,5	20	12,4
	KNHML14X2,0			724,4		
KNHM16X2,0		M16X2,0	M22X1,5	896,8	22	12,4
	KNHML16X2,0			855,2		
KNHM18X1,5		M18X1,5	M24X1,5	1084,4	24	16,8
	KNHML18X1,5			1051,5		
KNHM20X2,5		M20X2,5	M30X2,0	1774,3	30	17,5
	KNHML20X2,5			1736,4		
KNHM24X3,0		M24X3,0	M33X2,0	2189,4	33	19,0
	KNHML24X3,0			2161,9		

Part-no.	Installation dimensions				Hand installation tool part-no.	Removal dimensions	
	Ø D modified tap drill Ø	Ø E counter-sink Ø + 0,25	Thread F			Drill	
			Ø F class 6H	G min.		Ø	Depth
KNHM14X2,0	18,75 ^{+0,130} _{-0,025}	20,25	M20X1,5	22,5	KRTM14-02 / KNT03- HM14X2,0AU	17,50	4,75
KNHML14X2,0							
KNHM16X2,0	20,50 ^{+0,130} _{-0,025}	22,25	M22X1,5	24,5	KRTM16-02 / KNT03- HM16X2,0AU	17,75	6,35
KNHML16X2,0							
KNHM18X1,5	22,50 ^{+0,130} _{-0,025}	24,25	M24X1,5	26,5	KRTM18-02 / KNT03- HM18X1,5AU	19,75	6,35
KNHML18X1,5							
KNHM20X2,5	28,00 ^{+0,130} _{-0,025}	30,25	M30X2,0	34,5	KRTM20-02 / KNT03- HM20X2,5AU	25,75	6,35
KNHML20X2,5							
KNHM24X3,0	31,00 ^{+0,130} _{-0,025}	33,25	M33X2,0	37,5	KRTM24-02 / KNT03- HM24X3,0AU	28,75	6,35
KNHML24X3,0							

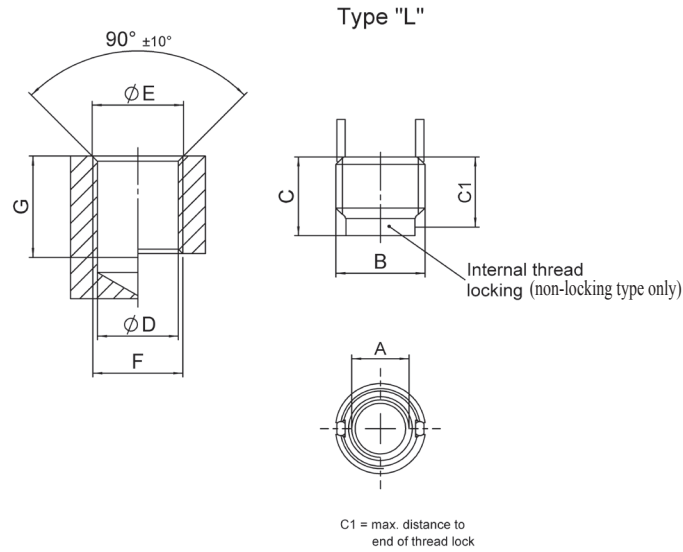

Part-no.		Dimensions				
Standard type "S"	Locking type "L"	Thread A Ø A	Thread B Ø B	Shear engagement inch ² (mm ²)	C inch (mm)	C1 inch (mm)
KNCA0256J		2-56" UNCJ-3B	8-32" UNC-3A	0,0157 (10,1)	0,12 (3,05)	0,088 (2,24)
KNCA0440J		4-40" UNCJ-3B	10-32" UNF-2A	0,0302 (19,5)	0,17 (4,32)	0,125 (3,18)
	KNCAL0440J			0,0302 (19,5)		0,125 (3,18)
KNC0632J		6-32" UNCJ-3B	12-28" UNF-2A	0,0329 (21,2)	0,17 (4,32)	0,125 (3,18)
	KNCL0632J			0,0329 (21,2)		0,125 (3,18)
KNCA0832J		8-32" UNCJ-3B	1/4-28" UNF-2A	0,0669 (43,2)	0,22 (5,59)	0,175 (4,45)
	KNCAL0832J			0,0669 (43,2)		0,175 (4,45)

Part-no.	Installation dimensions				Hand installation tool part-no.	Removal dimensions	
	Ø D modified tap drill Ø inch	Ø E counter- sink Ø inch	Thread F			Drill	
			Ø F	G min. inch (mm)		Ø inch (mm)	Depth inch (mm)
KNCA0256J	.134 ^{+0,003} -0,001	.166 ^{+0,001} -0,000	8-32	0,140 (3,56)	TKNC02	0,133 (2,87)	1/16 (1,59)
			UNCJ-2B				
KNCA0440J	.161 ^{+0,003} -0,001	.194 ^{+0,001} -0,000	10-32	0,160 (4,06)	TKNC04	0,136 (3,45)	3/32 (2,38)
KNCAL0440J			UNF-2B				
KNC0632J	.187 ^{+0,003} -0,001	.220 ^{+0,001} -0,000	12-28	0,160 (4,06)	TKNC06	0,159 (4,04)	3/32 (2,38)
KNCL0632J			UNF-2B				
KNCA0832J	.228 ^{+0,003} -0,001	.225 ^{+0,001} -0,000	1/4-28	0,210 (5,33)	TKNC08	0,199 (5,05)	1/8 (3,18)
KNCAL0832J			UNF-2B				



Type "S"

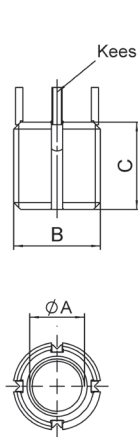

Kees:
Inserts with internal thread size of 1/4" and under are furnished with 2 locking kees
Inserts with internal thread size of 5/16" and above are furnished with 4 locking kees

Type "L"

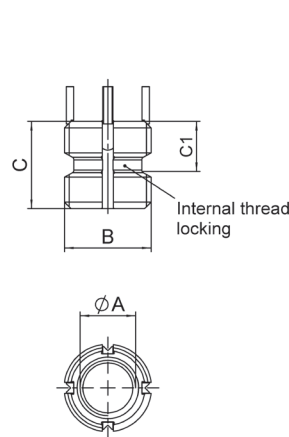

C1 = max. distance to end of thread lock

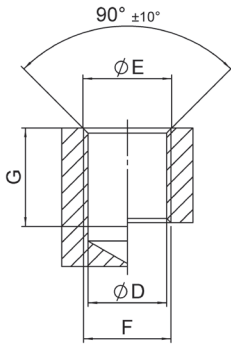

Part-no.		Dimensions				
Standard type "S"	Locking type "L"	Thread A Ø A class 3B	Thread B Ø B class 2A mod.	Shear engagement inch ² (mm ²)	C inch (mm)	C1 inch (mm)
KN1032J	KNL1032J	10-32	5/16-18	0,1517 (97,9)	0,31 (7,87)	0,31 (7,87)
				0,0945 (60,9)		
KN1024J	KNL1024J	10-24	5/16-18	0,1517 (97,9)	0,31 (7,87)	0,31 (7,87)
				0,0945 (61,0)		
KN428J	KNL428J	1/4-28	3/8-16	0,2371 (153,0)	0,37 (9,40)	0,33 (8,38)
				0,1726 (111,4)		
KN420J	KNL420J	1/4-20	3/8-16	0,2371 (153,0)	0,37 (9,40)	0,36 (9,14)
				0,1726 (111,4)		
KN524J	KNL524J	5/16-24	7/16-14	0,3049 (196,7)	0,43 (10,9)	0,34 (8,64)
				0,2321 (149,7)		
KN518J	KNL518J	5/16-18	7/16-14	0,3049 (196,7)	0,43 (10,9)	0,37 (9,40)
				0,2321 (149,7)		

Part-no.	Installation dimensions				Hand installation tool part-no.	Removal dimensions	
	Ø D modified tap drill Ø inch	Ø E countersink Ø inch +0,01 (mm)	Thread F			Drill	
			Ø F class 2B	G min. inch (mm)		Ø inch (mm)	Depth inch (mm)
KN1032J	0,272 (6,91)	0,323 (8,20)	5/16-18	0,37 (9,4)	TD1032L	7/32 (5,56)	5/32 (3,97)
KNL1032J							
KN1024J	0,272 (6,91)	0,323 (8,20)	5/16-18	0,37 (9,4)	TD1024L	7/32 (5,56)	5/32 (3,97)
KNL1024J							
KN428J	0,332 (8,43)	0,385 (9,78)	3/8-16	0,43 (10,9)	TD428L	9/32 (7,14)	3/16 (4,76)
KNL428J							
KN420J	0,332 (8,43)	0,385 (9,78)	3/8-16	0,43 (10,9)	TD420L	9/32 (7,14)	3/16 (4,76)
KNL420J							
KN524J	0,397 (10,08)	0,447 (11,35)	7/16-14	0,50 (12,7)	TD524L	11/32 (8,73)	3/16 (4,76)
KNL524J							
KN518J	0,397 (10,08)	0,447 (11,35)	7/16-14	0,50 (12,7)	TD518L	11/32 (8,73)	3/16 (4,76)
KNL518J							

Type "S"

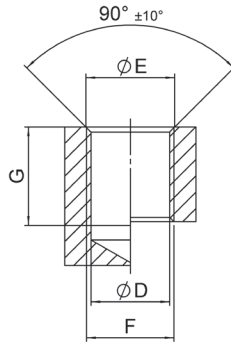
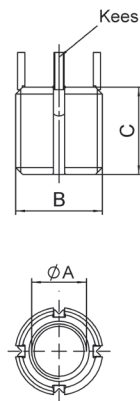

Kees:
Inserts with internal thread size of 1/4" and under are furnished with 2 locking kees
Inserts with internal thread size of 5/16" and above are furnished with 4 locking kees

Type "L"

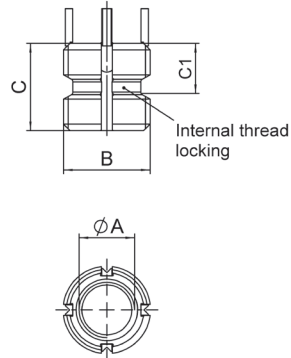

C1 = max. distance to end of thread lock

Part-no.		Dimensions				
Standard type "S"	Locking type "L"	Thread A Ø A class 3B	Thread B Ø B class 2A mod.	Shear engagement inch ² (mm ²)	C inch (mm)	C1 inch (mm)
KN624J	KNL624J	3/8-24	1/2-13	0,4299 (277,4)	0,50 (12,7)	0,36 (9,14)
				0,3366 (217,2)		
KN616J	KNL616J	3/8-16	1/2-13	0,4299 (277,4)	0,50 (12,7)	0,40 (10,16)
				0,3366 (217,2)		
KN720J	KNL720J	7/16-20	9/16-12	0,5665 (365,5)	0,56 (14,2)	0,41 (10,41)
				0,4606 (297,2)		
KN714J	KNL714J	7/16-14	9/16-12	0,5665 (365,5)	0,56 (14,2)	0,45 (11,43)
				0,4606 (297,2)		
KN820J	KNL820J	1/2-20	5/8-11	0,7175 (462,9)	0,62 (15,6)	0,42 (10,67)
				0,5906 (381,0)		
KN813J	KNL813J	1/2-13	5/8-11	0,7175 (462,9)	0,62 (15,6)	0,47 (11,94)
				0,5906 (381,0)		

Part-no.	Installation dimensions				Hand installation tool part-no.	Removal dimensions	
	Ø D modified tap drill Ø inch	Ø E countersink Ø inch +0,01 (mm)	Thread F			Ø inch (mm)	Depth inch (mm)
			Ø F class 2B	G min. inch (mm)			
KN624J	0,453 (11,51)	0,510 (12,95)	1/2-13	0,56 (14,2)	TD624L	13/32 (10,32)	3/16 (4,76)
KNL624J							
KN616J	0,453 (11,51)	0,510 (12,95)	1/2-13	0,56 (14,2)	TD616L	13/32 (10,32)	3/16 (4,76)
KNL616J							
KN720J	0,516 (13,11)	0,572 (14,53)	9/16-12	0,62 (15,7)	TD720L	15/32 (11,91)	3/16 (4,76)
KNL720J							
KN714J	0,516 (13,11)	0,572 (14,53)	9/16-12	0,62 (15,7)	TD714L	15/32 (11,91)	3/16 (4,76)
KNL714J							
KN820J	0,578 (14,68)	0,635 (16,13)	5/8-11	0,68 (17,3)	TD820L	17/32 (13,49)	3/16 (4,76)
KNL820J							
KN813J	0,578 (14,68)	0,635 (16,13)	5/8-11	0,68 (17,3)	TD813L	17/32 (13,49)	3/16 (4,76)
KNL813J							

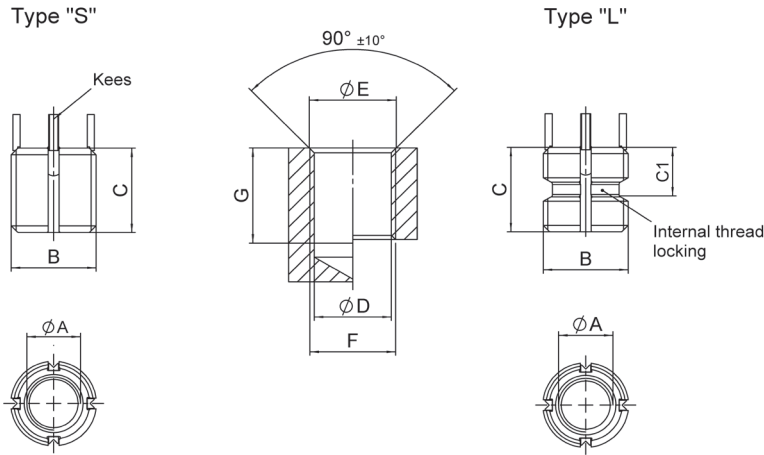

Kees:
Inserts with internal thread size of 1/4" and under are furnished with 2 locking kees
Inserts with internal thread size of 5/16" and above are furnished with 4 locking kees

C1 = max. distance to end of thread lock

Part-no.		Dimensions				
Standard type "S"	Locking type "L"	Thread A Ø A class 3B	Thread B Ø B class 2A mod.	Shear engagement inch ² (mm ²)	C inch (mm)	C1 inch (mm)
KNH0832J		8-32	5/16-18	0,1517 (97,87)	0,31 (7,87)	0,29 (7,37)
	KNHL0832J			0,0945 (60,97)		
KNH1032J		10-32	3/8-16	0,1901 (122,7)	0,31 (7,87)	0,31 (7,87)
	KNHL1032J			0,1156 (74,6)		
KNH1024J		10-24	3/8-16	0,1901 (122,7)	0,31 (7,87)	0,31 (7,87)
	KNHL1024J			0,1156 (74,6)		
KNH428J		1/4-28	7/16-14	0,2842 (183,4)	0,37 (9,40)	0,33 (8,38)
	KNHL428J			0,1970 (127,1)		
KNH420J		1/4-20	7/16-14	0,2842 (183,4)	0,37 (9,40)	0,33 (8,38)
	KNHL420J			0,1970 (127,1)		
KNH524J		5/16-24	1/2-13	0,3588 (231,5)	0,43 (10,9)	0,34 (8,64)
	KNHL524J			0,2608 (168,3)		

Part-no.	Installation dimensions					Removal dimensions	
	Ø D modified tap drill Ø inch	Ø E countersink Ø inch +0,01 (mm)	Thread F		Hand installation tool part-no.	Drill	
			Ø F class UNC-2B	G min. inch (mm)		Ø inch (mm)	Depth inch (mm)
KNH0832J	0,272 (6,91)	0,323 (8,20)	5/16-18	0,37 (9,4)	THD0832L	7/32 (5,56)	1/8 (3,18)
KNHL0832J							
KNH1032J	0,332 (8,43)	0,385 (9,78)	3/8-16	0,37 (9,4)	THD1032L	9/32 (7,14)	1/8 (3,18)
KNHL1032J							
KNH1024J	0,332 (8,43)	0,385 (9,78)	3/8-16	0,37 (9,4)	THD1024L	9/32 (7,14)	1/8 (3,18)
KNHL1024J							
KNH428J	0,397 (10,08)	0,447 (11,35)	7/16-14	0,43 (10,9)	THD428L	11/32 (8,73)	3/16 (4,76)
KNHL428J							
KNH420J	0,397 (10,08)	0,447 (11,35)	7/16-14	0,43 (10,9)	THD420L	11/32 (8,73)	3/16 (4,76)
KNHL420J							
KNH524J	0,453 (11,51)	0,510 (12,95)	1/2-13	0,50 (12,7)	THD524L	13/32 (10,32)	3/16 (4,76)
KNHL524J							

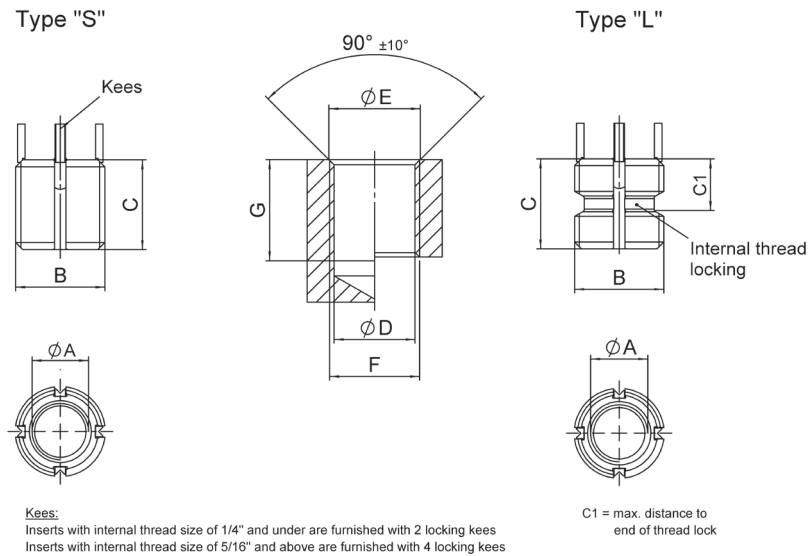

Part-no.		Dimensions				
Standard type "S"	Locking type "L"	Thread A Ø A class 3B	Thread B Ø B class 2A mod.	Shear engagement inch ² (mm ²)	C inch (mm)	C1 inch (mm)
KNH518J	KNHL518J	5/16-18	1/2-13	0,3588 (231,5)	0,43 (10,9)	0,37 (9,40)
				0,2608 (168,3)		
KNH624J	KNHL624J	3/8-24	9/16-12	0,4975 (321,0)	0,50 (12,7)	0,37 (9,40)
				0,3843 (248,0)		
KNH616J	KNHL616J	3/8-16	9/16-12	0,4975 (321,0)	0,50 (12,7)	0,41 (10,41)
				0,3843 (248,0)		
KNH720J	KNHL720J	7/16-20	5/8-11	0,7172 (462,7)	0,62 (15,8)	0,42 (10,67)
				0,5831 (376,2)		
KNH714J	KNHL714J	7/16-14	5/8-11	0,7172 (462,7)	0,62 (15,8)	0,46 (11,68)
				0,5831 (376,2)		

Part-no.	Installation dimensions				Hand installation tool part-no.	Removal dimensions	
	Ø D modified tap drill Ø inch	Ø E countersink Ø inch +0,01 (mm)	Thread F			Drill	
			Ø F class UNC-2B	G min. inch (mm)		Ø inch (mm)	Depth inch (mm)
KNH518J	0,453 (11,51)	0,510 (12,95)	1/2-13	0,50 (12,7)	THD518L	13/32 (10,32)	3/16 (4,76)
KNHL518J							
KNH624J	0,516 (13,11)	0,572 (14,53)	9/16-12	0,56 (14,2)	THD624L	15/32 (11,91)	3/16 (4,76)
KNHL624J							
KNH616J	0,516 (13,11)	0,572 (14,53)	9/16-12	0,56 (14,2)	THD616L	15/32 (11,91)	3/16 (4,76)
KNHL616J							
KNH720J	0,578 (14,68)	0,635 (16,13)	5/8-11	0,68 (17,27)	THD720L	17/32 (13,49)	3/16 (4,76)
KNHL720J							
KNH714J	0,578 (14,68)	0,635 (16,13)	5/8-11	0,68 (17,27)	THD714L	17/32 (13,49)	3/16 (4,76)
KNHL714J							

Type "S"

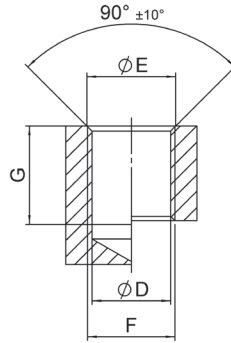
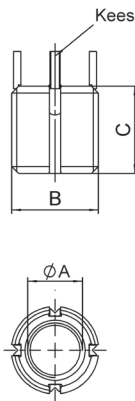

Type "L"

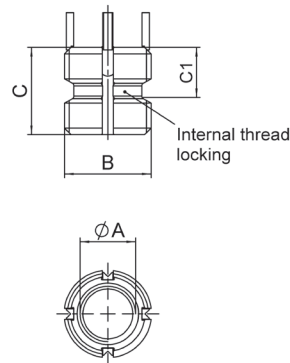

Kees:
Inserts with internal thread size of 1/4" and under are furnished with 2 locking kees
Inserts with internal thread size of 5/16" and above are furnished with 4 locking kees

C1 = max. distance to end of thread lock

Part-no.		Dimensions				
Standard type "S"	Locking type "L"	Thread A Ø A class 3B	Thread B Ø B class 2A mod.	Shear engagement inch ² (mm ²)	C inch (mm)	C1 inch (mm)
KNH820J	KNHL820J	1/2-20	11/16-11NS	0,8884 (573,2)	0,68 (17,3)	0,42 (10,67)
				0,7368 (475,4)		
KNH813J	KNHL813J	1/2-13	11/16-11NS	0,8884 (573,2)	0,68 (17,3)	0,47 (11,94)
				0,7368 (475,4)		
KNH918J	KNHL918J	9/16-18	13/16-16	1,2493 (806,0)	0,81 (20,6)	0,48 (12,19)
				1,0247 (661,1)		
KNH912J	KNHL912J	9/16-12	13/16-16	1,2493 (806,0)	0,81 (20,6)	0,54 (13,72)
				1,0247 (661,1)		
KNH1018J	KNHL1018J	5/8-18	7/8-14	1,4866 (959,1)	0,87 (22,1)	0,49 (12,47)
				1,2415 (801,0)		
KNH1011J	KNHL1011J	5/8-11	7/8-14	1,4866 (959,1)	0,87 (22,1)	0,57 (14,48)
				1,2415 (801,0)		

Part-no.	Installation dimensions				Hand installation tool part-no.	Removal dimensions	
	Ø D modified tap drill Ø inch	Ø E countersink Ø inch +0,01 (mm)	Thread F			Drill	
			Ø F class UNC-2B	G min. inch (mm)		Ø inch (mm)	Depth inch (mm)
KNH820J	0,641 (16,28)	0,700 (17,80)	11/16-11NS	0,75 (19,06)	THD820L	19/32 (15,08)	3/16 (4,76)
KNHL820J							
KNH813J	0,641 (16,28)	0,700 (17,80)	11/16-11NS	0,75 (19,06)	THD813L	19/32 (15,08)	3/16 (4,76)
KNHL813J							
KNH918J	0,766 (19,46)	0,822 (20,88)	13/16-16UN	0,94 (23,88)	THD918L	23/32 (18,26)	3/16 (4,76)
KNHL918J							
KNH912J	0,766 (19,46)	0,822 (20,88)	13/16-16UN	0,94 (23,88)	THD912L	23/32 (18,26)	3/16 (4,76)
KNHL912J							
KNH1018J	0,828 (21,03)	0,885 (22,48)	7/8-14UNF	1,00 (25,40)	THD1018L	25/32 (19,84)	3/16 (4,76)
KNHL1018J							
KNH1011J	0,828 (21,03)	0,885 (22,48)	7/8-14 UNF	1,00 (25,40)	THD1011L	25/32 (19,84)	3/16 (4,76)
KNHL1011J							

Type "S"

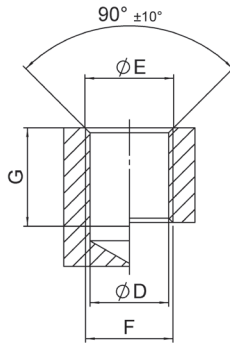
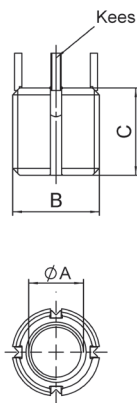

Type "L"

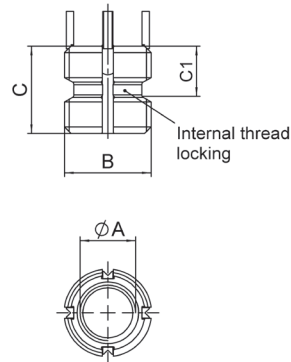

Kees:
Inserts with internal thread size of 1/4" and under are furnished with 2 locking kees
Inserts with internal thread size of 5/16" and above are furnished with 4 locking kees

C1 = max. distance to end of thread lock

Part-no.		Dimensions				
Standard type "S"	Locking type "L"	Thread A Ø A class 3B	Thread B Ø B class 2A mod.	Shear engagement inch ² (mm ²)	C inch (mm)	C1 inch (mm)
KNH1216J		3/4-16	1-1/8-12	2,4901 (1606,5)	1,12 (28,5)	
	KNHL1216J			2,4478 (1579,3)	1,25 (31,8)	0,68 (17,27)
KNH1210J		3/4-10	1-1/8-12	2,4901 (1606,5)	1,12 (28,5)	
	KNHL1210J			2,4478 (1579,3)	1,25 (31,8)	0,75 (19,05)
KNH1414J		7/8-14	1-1/4-12	3,1370 (2024,1)	1,25 (31,8)	
	KNHL1414J			3,0775 (1985,6)	1,37 (34,8)	0,69 (17,53)
KNH1409J		7/8-9	1-14/12	3,1370 (2024,1)	1,25 (31,8)	
	KNHL1409J			3,0775 (1985,6)	1,37 (34,8)	0,77 (19,56)
KNH1612J		1-12	1-3/8-12	3,8381 (2476,3)	1,37 (34,8)	
	KNHL1612J			3,7929 (2447,2)	1,50 (38,1)	0,78 (19,81)
KNH1608J		1-8	1-3/8-12	3,8381 (2476,3)	1,37 (34,8)	
	KNHL1608J			3,7929 (2447,2)	1,50 (38,1)	0,86 (21,84)

Part-no.	Installation dimensions					Removal dimensions	
	Ø D modified tap drill Ø inch	Ø E countersink Ø inch +0,01 (mm)	Thread F		Hand installation tool part-no.	Drill	
			Ø F class UNC- 2B	G min. inch (mm)		Ø inch (mm)	Depth inch (mm)
KNH1216J	1,062 (26,97)	1,145 (29,08)	1-1/8-12 UNF	1,31 (33,27) 1,44 (36,58)	THD1216L	31/32 (24,61)	5/16 (7,94)
KNHL1216J							
KNH1210J	1,062 (26,97)	1,145 (29,08)	1-1/8-12 UNF	1,31 (33,27) 1,44 (36,58)	THD1210L	31/32 (24,61)	5/16 (7,94)
KNHL1210J							
KNH1414J	1,187 (30,15)	1,270 (32,26)	1-1/4-12 UNF	1,44 (36,58) 1,56 (39,62)	THD1414L	1-3/32 (27,78)	5/16 (7,94)
KNHL1414J							
KNH1409J	1,187 (30,15)	1,270 (32,26)	1-1/4-12 UNF	1,44 (36,58) 1,56 (39,62)	THD1409L	1-3/32 (27,78)	5/16 (7,94)
KNHL1409J							
KNH1612J	1,312 (33,32)	1,395 (35,43)	1-3/8-12 UNF	1,56 (39,62) 1,68 (42,67)	THD1612L	1-7/32 (30,96)	5/16 (7,94)
KNHL1612J							
KNH1608J	1,312 (33,32)	1,395 (35,43)	1-3/8-12 UNF	1,56 (39,62) 1,68 (42,67)	THD1608L	1-7/32 (30,96)	5/16 (7,94)
KNHL1608J							

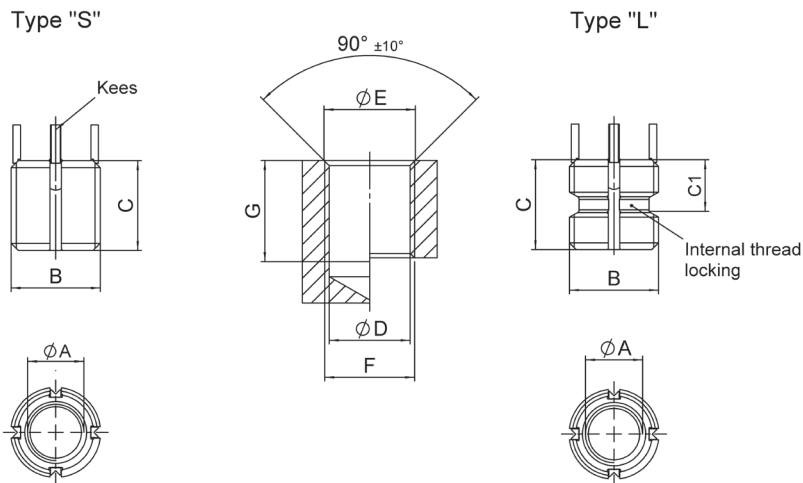

Kees:
Inserts with internal thread size of 10-24", 10-32" and under are furnished with 2 locking kees
Inserts with internal thread size of 1/4" and above are furnished with 4 locking kees

C1 = max. distance to end of thread lock

Part-no.		Dimensions				
Standard type "S"	Locking type "L"	Thread A Ø A class 3B	Thread B Ø B class 2A mod.	Shear engagement inch ² (mm ²)	C inch (mm)	C1 inch (mm)
KNHXH1032J		10-32	7/16-14	0,2299 (148,3)	0,31 (7,9)	0,31 (7,90)
	KNHXHL1032J			0,1403 (90,5)		
KNHXH1024J		10-24	7/16-14	0,2299 (148,3)	0,31 (7,9)	0,31 (7,90)
	KNHXHL1024J			0,1403 (90,5)		
KNHXH428J		1/4-28	1/2-13	0,2997 (193,4)	0,37 (9,4)	0,33 (8,38)
	KNHXHL428J			0,2005 (129,4)		
KNHXH420J		1/4-20	1/2-13	0,2997 (193,4)	0,37 (9,4)	0,36 (9,14)
	KNHXHL420J			0,2005 (129,4)		
KNHXH524J		5/16-24	9/16-12	0,4163 (268,6)	0,43 (10,9)	0,34 (8,64)
	KNHXHL524J			0,3029 (195,4)		

Part-no.	Installation dimensions				Hand installation tool part-no.	Removal dimensions	
	Ø D modified tap drill Ø inch	Ø E countersink Ø inch +0,01 (mm)	Thread F			Drill	
			Ø F class UNC- 2B	G min. inch (mm)		Ø inch (mm)	Depth inch (mm)
KNHXH1032J	0,397 (10,08)	0,447 (11,35)	7/16-14	0,37 (9,40)	THXHD1032L	11/32 (8,73)	3/16 (4,76)
KNHXHL1032J							
KNHXH1024J	0,397 (10,08)	0,447 (11,35)	7/16-14	0,37 (9,40)	THXHD1024L	11/32 (8,73)	3/16 (4,76)
KNHXHL1024J							
KNHXH428J	0,453 (11,51)	0,510 (12,95)	1/2-13	0,44 (11,18)	THXHD428L	13/32 (10,32)	3/16 (4,76)
KNHXHL428J							
KNHXH420J	0,453 (11,51)	0,510 (12,95)	1/2-13	0,44 (11,18)	THXHD420L	13/32 (10,32)	3/16 (4,76)
KNHXHL420J							
KNHXH524J	0,516 (13,11)	0,572 (14,53)	9/16-12	0,50 (12,70)	THXHD524L	15/32 (11,91)	3/16 (4,76)
KNHXHL524J							

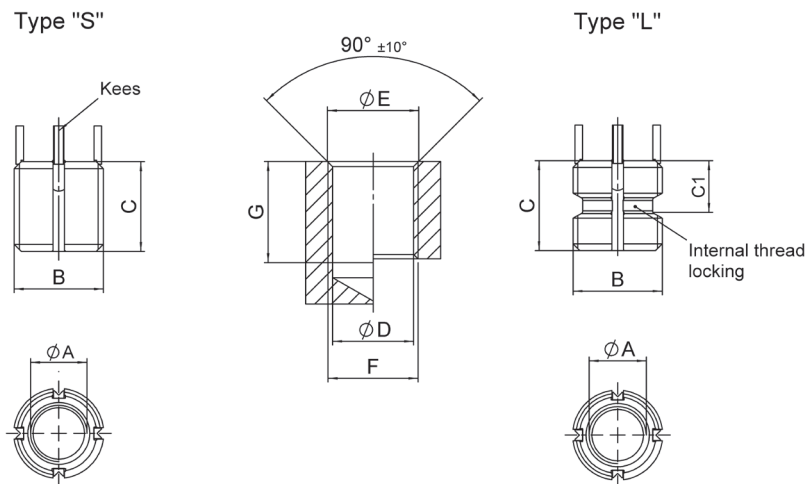

Kees:
Inserts with internal thread size of 10-24", 10-32" and under are furnished with 2 locking kees
Inserts with internal thread size of 1/4" and above are furnished with 4 locking kees

C1 = max. distance to end of thread lock

Part-no.		Dimensions				
Standard type "S"	Locking type "L"	Thread A Ø A class 3B	Thread B Ø B class 2A mod.	Shear engagement inch ² (mm ²)	C inch (mm)	C1 inch (mm)
KNHXH518J		5/16-18	9/16-12	0,4163 (268,6)	0,43 (10,9)	0,37 (9,40)
	KNHXHL518J			0,3029 (195,4)		
KNHXH624J		3/8-24	5/8-11	0,5584 (360,3)	0,50 (12,7)	0,37 (9,40)
	KNHXHL624J			0,4234 (273,8)		
KNHXH616J		3/8-16	5/8-11	0,5584 (360,3)	0,50 (12,7)	0,41 (10,41)
	KNHXHL616J			0,4234 (273,8)		
KNHXH720J		7/16-20	11/16-11 NS	0,8000 (516,1)	0,62 (15,6)	0,42 (10,67)
	KNHXHL720J			0,6498 (419,2)		
KNHXH714J		7/16-14	11/16-11 NS	0,8000 (516,1)	0,62 (15,6)	0,46 (11,68)
	KNHXHL714J			0,6498 (419,2)		

Part-no.	Installation dimensions				Hand installation tool part-no.	Removal dimensions	
	Ø D modified tap drill Ø inch	Ø E countersink Ø inch +0,01 (mm)	Thread F			Drill	
			Ø F class UNC- 2B	G min. inch (mm)		Ø inch (mm)	Depth inch (mm)
KNHXH518J	0,516 (13,11)	0,572 (14,53)	9/16-12	0,50 (12,70)	THXHD518L	15/32 (11,91)	3/16 (4,76)
KNHXHL518J							
KNHXH624J	0,578 (14,68)	0,635 (16,13)	5/8-11	0,56 (14,22)	THXHD624L	17/32 (13,49)	3/16 (4,76)
KNHXHL624J							
KNHXH616J	0,578 (14,68)	0,635 (16,13)	5/8-11	0,56 (14,22)	THXHD616L	17/32 (13,49)	3/16 (4,76)
KNHXHL616J							
KNHXH720J	0,641 (16,28)	0,700 (17,80)	11/16-11 NS	0,68 (17,27)	THXHD720L	19/32 (15,08)	3/16 (4,76)
KNHXHL720J							
KNHXH714J	0,641 (16,28)	0,700 (17,80)	11/16-11 NS	0,68 (17,27)	THXHD714L	19/32 (15,08)	3/16 (4,76)
KNHXHL714J							

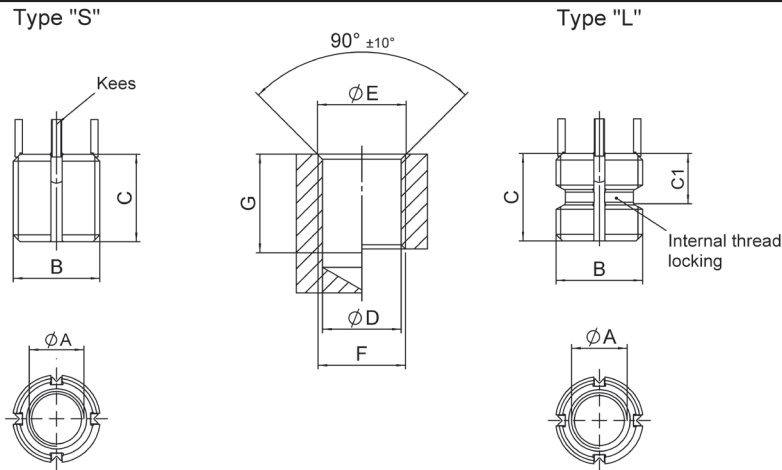

Kees:
Inserts with internal thread size of 10-24", 10-32" and under are furnished with 2 locking kees
Inserts with internal thread size of 1/4" and above are furnished with 4 locking kees

C1 = max. distance to end of thread lock

Part-no.		Dimensions				
Standard type "S"	Locking type "L"	Thread A Ø A class 3B	Thread B Ø B class 2A mod.	Shear engagement inch ² (mm ²)	C inch (mm)	C1 inch (mm)
KNHXH820J		1/2-20	13/16-16	1,0293 (664,1)	0,68 (17,3)	0,42 (10,67)
	KNHXHL820J			0,8642 (557,6)		
KNHXH813J		1/2-13	13/16-16	1,0293 (664,1)	0,68 (17,3)	0,47 (11,94)
	KNHXHL813J			0,8642 (557,6)		
KNHXH918J		9/16-18	7/8-14	1,3761 (887,8)	0,81 (20,6)	0,48 (12,19)
	KNHXHL918J			1,1131 (718,1)		
KNHXH912J		9/16-12	7/8-14	1,3761 (887,8)	0,81 (20,6)	0,54 (13,72)
	KNHXHL912J			1,1131 (718,1)		
KNHXH1018J		5/8-18	1-12	1,6420 (1059,4)	0,87 (22,1)	0,51 (12,95)
	KNHXHL1018J			1,2770 (823,9)		
KNHXH1011J		5/8-11	1-12	1,6420 (1059,4)	0,87 (22,1)	0,59 (14,99)
	KNHXHL1011J			1,2770 (823,9)		

Part-no.	Installation dimensions				Hand installation tool part-no.	Removal dimensions	
	Ø D modified tap drill Ø inch	Ø E countersink Ø inch +0,01 (mm)	Thread F			Drill	
			Ø F class UNC-2B	G min. inch (mm)		Ø inch (mm)	Depth inch (mm)
KNHXH820J	0,766 (19,46)	0,822 (20,88)	13/16-16 UNF	0,75 (19,05)	THXHD820L	23/32 (18,26)	3/16 (4,76)
KNHXHL820J							
KNHXH813J	0,766 (19,46)	0,822 (20,88)	13/16-16 UNF	0,75 (19,05)	THXHD813L	23/32 (18,26)	3/16 (4,76)
KNHXHL813J							
KNHXH918J	0,828 (21,03)	0,885 (22,48)	7/8-14 UNF	0,94 (23,88)	THXHD918L	25/32 (19,84)	3/16 (4,76)
KNHXHL918J							
KNHXH912J	0,828 (21,03)	0,885 (22,48)	7/8-14 UNF	0,94 (23,88)	THXHD912L	25/32 (19,84)	3/16 (4,76)
KNHXHL912J							
KNHXH1018J	0,937 (23,80)	1,020 (25,91)	1-12 UNF	1,00 (25,40)	THXHD1018L	27/32 (21,43)	5/16 (7,94)
KNHXHL1018J							
KNHXH1011J	0,937 (23,80)	1,020 (25,91)	1-12 UNF	1,00 (25,40)	THXHD1011L	27/32 (21,43)	5/16 (7,94)
KNHXHL1011J							

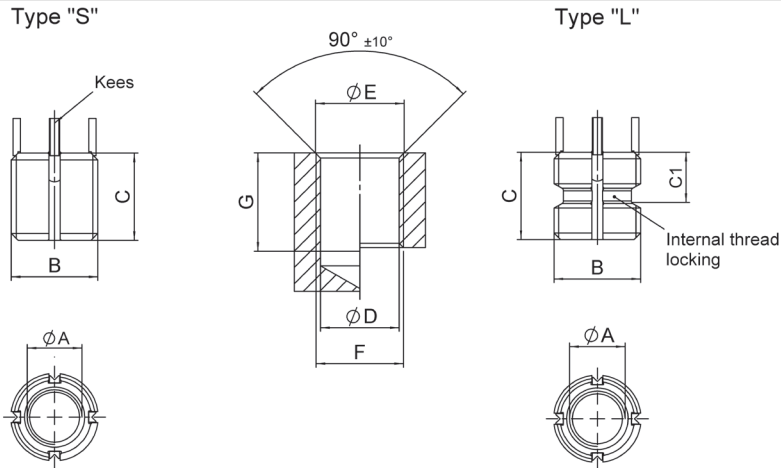

Kees:
Inserts with internal thread size of 10-24", 10-32" and under are furnished with 2 locking kees
Inserts with internal thread size of 1/4" and above are furnished with 4 locking kees

C1 = max. distance to end of thread lock

Part-no.		Dimensions				
Standard type "S"	Locking type "L"	Thread A Ø A class 3B	Thread B Ø B class 2A mod.	Shear engagement inch ² (mm ²)	C inch (mm)	C1 inch (mm)
KNHXH1216J		3/4-16	1-1/4-12	2,7966 (1804,2)	1,12 (28,5)	
	KNHXHL1216J			2,5505 (1645,5)	1,25 (31,8)	0,57 (14,48)
KNHXH1210J		3/4-10	1-1/4-12	2,7966 (1804,2)	1,12 (28,5)	
	KNHXHL1210J			2,5505 (1645,5)	1,25 (31,8)	0,64 (16,26)
KNHXH1414J		7/8-14	1-3/8-12	3,4652 (2235,6)	1,25 (31,8)	
	KNHXHL1414J			3,2769 (2114,1)	1,37 (34,8)	0,63 (16,00)
KNHXH1409J		7/8-9	1-3/8-12	3,4652 (2235,6)	1,25 (31,8)	
	KNHXHL1409J			3,2769 (2114,1)	1,37 (34,8)	0,71 (18,03)
KNHXH1612J		1-12	1-1/2-12	4,2374 (2733,8)	1,37 (34,8)	
	KNHXHL1612J			4,2135 (2718,4)	1,50 (38,1)	0,70 (17,78)
KNHXH1608J		1-8	1-1/2-12	4,2374 (2733,8)	1,37 (34,8)	
	KNHXHL1608J			4,2135 (2718,4)	1,50 (38,1)	0,78 (19,81)

Part-no.	Installation dimensions					Removal dimensions	
	Ø D modified tap drill Ø inch	Ø E countersink Ø inch +0,01 (mm)	Thread F		Hand installation tool part-no.	Drill	
			Ø F class UNC-2B	G min. inch (mm)		Ø inch (mm)	Depth inch (mm)
KNHXH1216J	1,187 (30,15)	1,270 (32,26)	1-1/4-12 UNF	1,31 (33,27) 1,44 (36,58)	THXHD1216L	1-3/32 (27,78)	5/16 (7,94)
KNHXHL1216J							
KNHXH1210J	1,187 (30,15)	1,270 (32,26)	1-1/4-12 UNF	1,31 (33,27) 1,44 (36,58)	THXHD1210L	1-3/32 (27,78)	5/16 (7,94)
KNHXHL1210J							
KNHXH1414J	1,312 (33,32)	1,395 (35,43)	1-3/8-12 UNF	1,44 (36,58) 1,56 (39,62)	THXHD1414L	1-7/32 (30,96)	5/16 (7,94)
KNHXHL1414J							
KNHXH1409J	1,312 (33,32)	1,395 (35,43)	1-3/8-12 UNF	1,44 (36,58) 1,56 (39,62)	THXHD1409L	1-7/32 (30,96)	5/16 (7,94)
KNHXHL1409J							
KNHXH1612J	1,437 (36,50)	1,520 (38,61)	1-1/2-12 UNF	1,56 (39,62) 1,38 (42,67)	THXHD1612L	1-11/32 (34,13)	5/16 (7,94)
KNHXHL1612J							
KNHXH1608J	1,437 (36,50)	1,520 (38,61)	1-1/2-12 UNF	1,56 (39,62) 1,38 (42,67)	THXHD1608L	1-11/32 (34,13)	5/16 (7,94)
KNHXHL1608J							



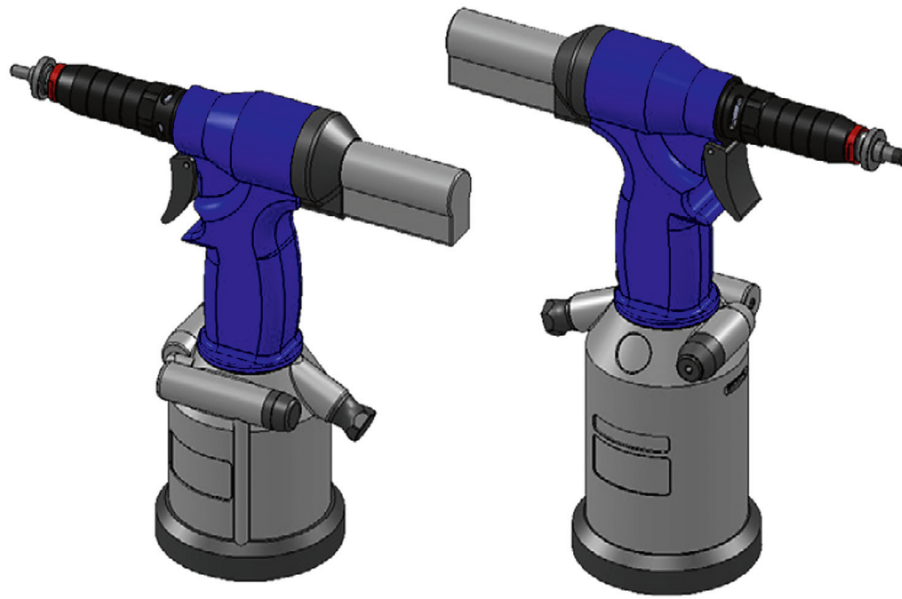

HYDRO-PNEUMATIC TOOLS FOR KEENSERTS®

Features

- The hydro-pneumatic Power Tool 3352PTC-1 is designed to install metric KEENSERTS® from sizes M5 to M12 and imperial sizes from 1032/1024 to 8137820. The slightly bigger 3352PTC-2 has a larger stroke to install M5 to M24 sized metric KEENSERTS®. For each size of KEENSERTS® a specific nose piece is required.
- Individual adjustments can be made using the integrated force control depending on size of the KEENSERTS® and hardness of the surrounding material.
- Due to the one-button operation it is easy to operate. The installation is quick, consistent and reliable.
- The hydro-pneumatic system is low maintenance, ergonomic and lightweight.
- Please note: Next to the Power Tool an appropriate nose piece for each size of KEENSERTS® has to be ordered separately.
- Of Course the nosepieces are also compatible with the E-Drive Power Tool EPT1.

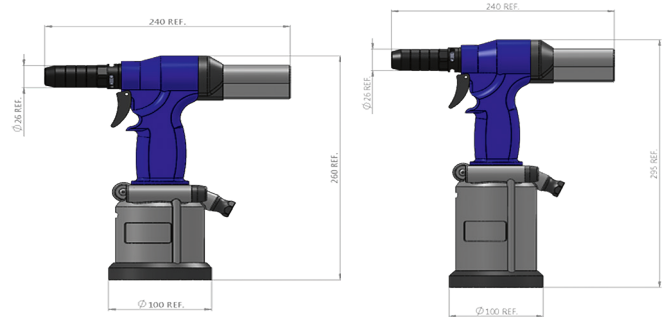

Technical Data

Tool	3352PT1	3352PT2
Air working pressure	6 bar / 90 PSI	6 bar / 90 PSI
Min. – Max. air pressure	5 - 7 bar / 70 - 100 PSI	5 - 7 bar / 70 - 100 PSI
Air consumption per cycle at 6 bar	5 Liter / 1.3 gallons	5 Liter / 1.3 gallons
Max. stroke	6.5 mm / 0.26 inch	8 mm / 0.31 inch
Max. force	19,000 N / 4,300 lbf	19,000 N / 4,300 lbf
Weight (without nosepiece)	1.800 Kg / 4 pounds	2.200 Kg / 4.85 pounds
Vibrations	< 2.5 m/s ² / 8.2 ft/s ²	< 2.5 m/s ² / 8.2 ft/s ²
Noise Level	76 dB (A)	76 dB (A)

Standard Accessoires

Ref.	Code	Qty.	Description
1	3352PTC-1 or 3352PTC-2	1	Power Tool complete, consists of:
	3352PT1 or 3352PT2	1	Power Tool
2	3352-3064400	1	Oil Bottle (Type ISO VG 32 100CC)
3	3352-1010	1	Plastic Tool Case
4	3352-0207300	1	Tool Wrench
5	3352-2533800	1	Removal Bolt
6	3352-4154200	1	Allen Wrench 3,0mm
	MNL-3352-1	1	Instruction Manual
	MNL-3352-2	1	Installation Manual

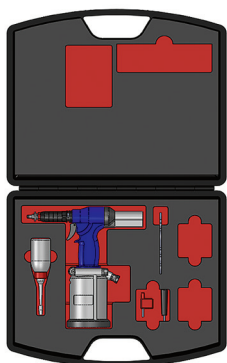

1



2

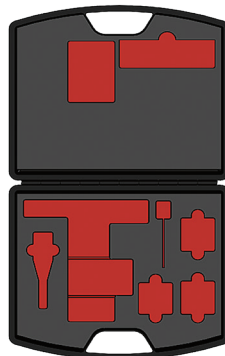

3



4



5



6

Nosepieces < M12

The Power Tools 3352PTC-1 and 3352PTC-2 comes without nosepieces, these have to be ordered separately according to the users needs.

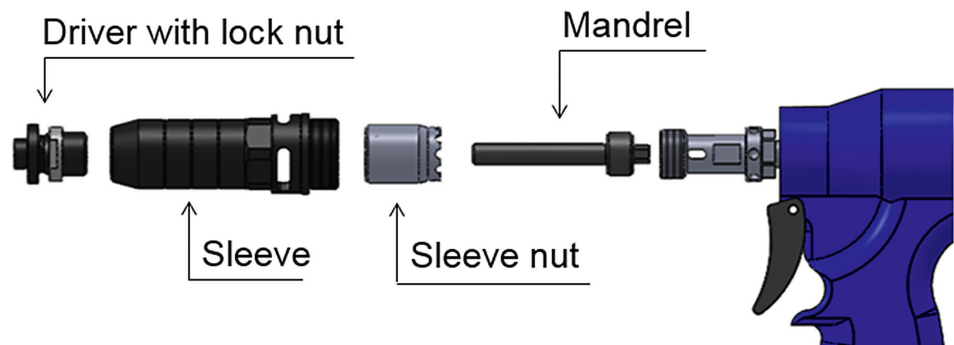

Mandrel, Driver and Lock Nut are part of the nose piece set for KEENSERTS® <M12

The nosepieces are a modular 3 piece design meaning next to the nosepiece set each component is available as an individual part. The customer can transform a nosepiece for a regular KEENSERTS® into a heavy type nose piece by just buying and replacing one part.







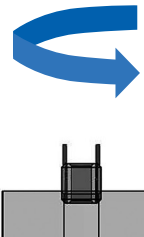
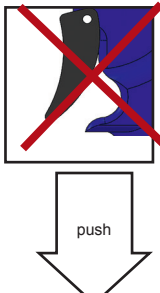

Nosepieces > M12

Metric nosepieces from M16 to M24 are designed differently and sold as a set only.

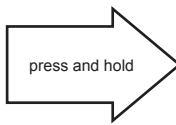
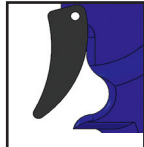
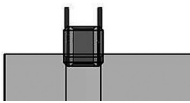

Installation Procedure

Step 1	Step 2	Step 3	Step 4	Step 5
<p>Screw in the KEENSERTS® by hand for about one to two turns.</p>	<p>Push the outer thread of the mandrel into the inner thread of the KEENSERTS®. The screw-in process will start automatically activated by the pushing force.</p>	<p>Do not press the trigger yet. The screw-in operation stops automatically once the insert reaches its final position (when the thicker part of the Kees touch the countersunk surface).</p>	<p>Then push the trigger for Kees to be pressed in.</p>	<p>Keep the trigger pressed, after the Kees are pressed in the mandrel will rotate counterclockwise until it gets out of the KEENSERTS®. Then release the trigger.</p>
		<p>Stop</p> 		
				

Available metric Nosepieces



KEENSERTS® Size	Nosepiece Set	Spare Part Mandrel	Spare Part Driver	Spare Part Lock Nut
----------------------------	----------------------	---------------------------	--------------------------	----------------------------

KNM Serie

KNM(L)5x0.8	3352TM5x0.8AY	3352S04M5x0.8BY	3352S05M5AY	3352S03-1AY
KNM(L)6x1.0	3352TM6x1.0AY	3352S04M6x1.0BY	3352S05M6AY	
KNM(L)8x1.25	3352TM8x1.25AY	3352S04M8x1.25BY	3352S05M8AY	
KNM(L)10x1.5	3352TM10x1.5AY	3352S04M10x1.5BY	3352S05M10AY	
KNM(L)12x1.75	3352TM12x1.75AY	3352S04M12x1.75BY	3352S05M12AY	

KNHM Series

KNHM(L)5x0.8	3352THM5x0.8AY	3352S04M5x0.8BY	3352S05HM5AY	3352S03-1AY
KNHM(L)6x1.0	3352THM6x1.0AY	3352S04M6x1.0BY	3352S05HM6AY	
KNHM(L)8x1.25	3352THM8x1.25AY	3352S04M8x1.25BY	3352S05HM8AY	
KNHM(L)10x1.5	3352THM10x1.5AY	3352S04M10x1.5BY	3352S05HM10AY	
KNHM(L)12x1.75	3352THM12x1.75AY	3352S04M12x1.75BY	3352S05HM12AY	

**KNHM Series heavy duty Nosepieces
(3352PTC-2 required)**



KNHM16x2.0	3352THM16x2.0AY	Available as set only
KNHM18x1.5	3352THM18x1.5AY	
KNHM20x2.5	3352THM20x2.5AY	
KNHM24x3.0	3352THM24x3.0AY	

Available imperial Nosepieces



KEENSERTS® size	Nosepiece Set	Spare Part Mandrel	Spare Part Driver	Spare Part Lock Nut
------------------------	----------------------	---------------------------	--------------------------	----------------------------

KNJ Serie

KN(L)1032J	3352T1032AY	3352S01-1032BY	3352S02-10AY	3352S03-1AY
KN(L)1024J	3352T1024AY	3352S01-1024BY		
KN(L)428J	3352T428AY	3352S01-428BY	3352S02-1/4AY	
KN(L)420J	3352T420AY	3352S01-420BY		
KN(L)524J	3352T524AY	3352S01-524BY	3352S02-5/16AY	
KN(L)518J	3352T518AY	3352S01-518BY		
KN(L)624J	3352T624AY	3352S01-624BY	3352S02-3/8AY	
KN(L)616J	3352T616AY	3352S01-616BY		
KN(L)720J	3352T720AY	3352S01-720BY	3352S02-7/16AY	
KN(L)714J	3352T714AY	3352S01-714BY		
KN(L)820J	3352T820AY	3350S01-820BY	3352S02-1/2AY	
KN(L)813J	3352T813AY	3352S01-813BY		

KNHJ Series

KNH(L)1032J	3352TH1032AY	3352S01-1032BY	3352S02-H10AY	3352S03-1AY
KNH(L)1024J	3352TH1024AY	3352S01-1024BY		
KNH(L)428J	3352TH428AY	3352S01-428BY	3352S02-H1/4AY	
KNH(L)420J	3352TH420AY	3352S01-420BY		
KNH(L)524J	3352TH524AY	3352S01-524BY	3352S02-H5/16AY	
KNH(L)518J	3352TH518AY	3352S01-518BY		
KNH(L)624J	3352TH624AY	3352S01-624BY	3352S02-H3/8AY	
KNH(L)616J	3352TH616AY	3352S01-616BY		
KNH(L)720J	3352TH720AY	3352S01-720BY	3352S02-H7/16AY	
KNH(L)714J	3352TH714AY	3352S01-714BY		
KNH(L)820J	3352TH820AY	3352S01-820BY	3352S02-H1/2AY	
KNH(L)813J	3352TH813AY	3352S01-813BY		

KEENSERTS®

Hand Tools

KNT Series



Introducing the new KNT line of KEENSERTS® Hand Tools

Next to a fast and easy installation a save, repeatable and reliable installation process, even for untrained personnel, was on the agenda for this new line of tools.

This was realized with a tool working on the telescopic principle that gives an excellent guidance during installation. Any tilting of the tool that could result in bending or breaking of the kees is eliminated.

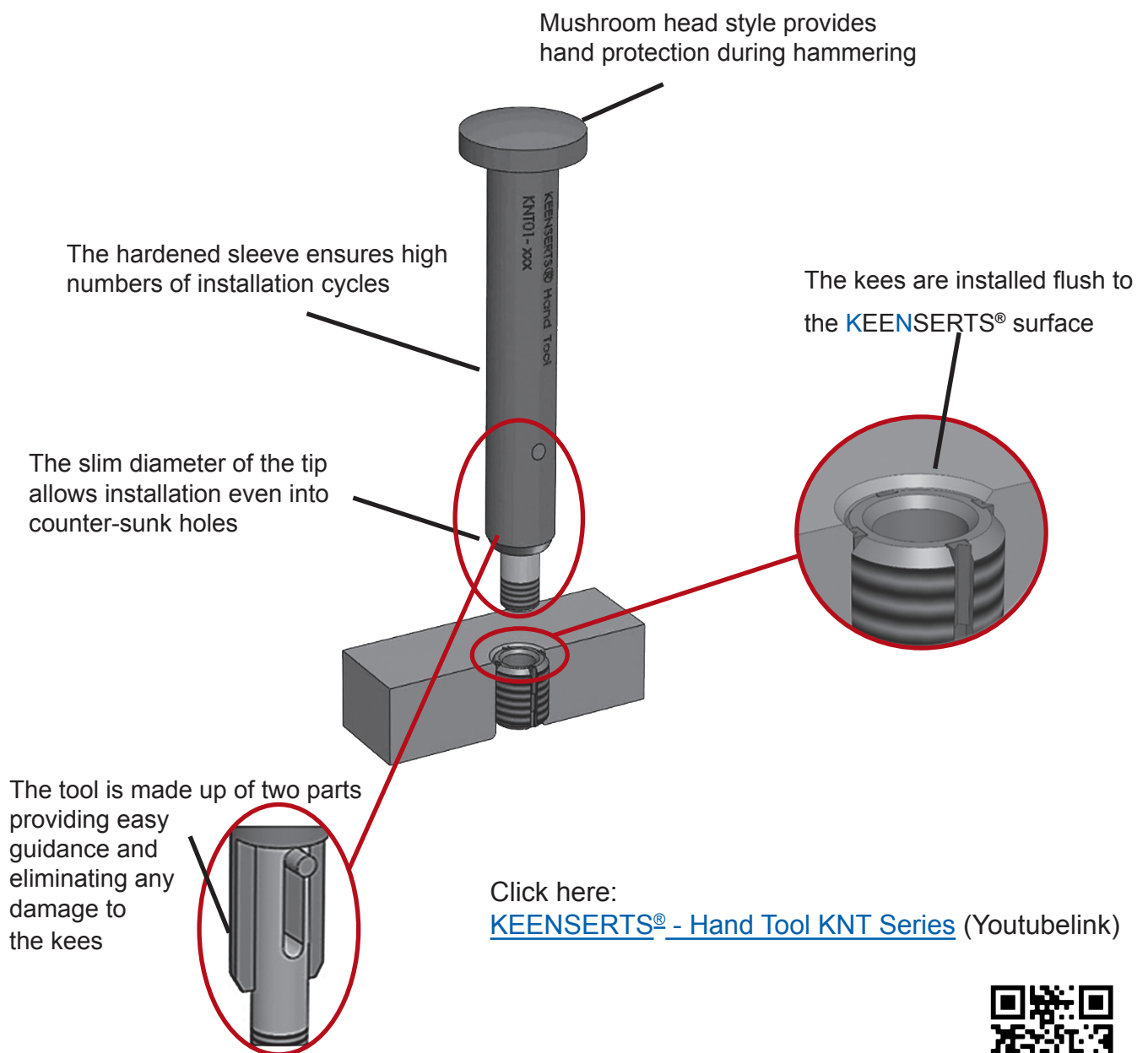

Installation Process

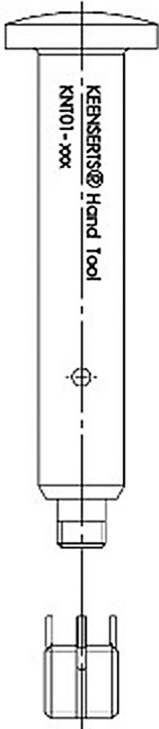
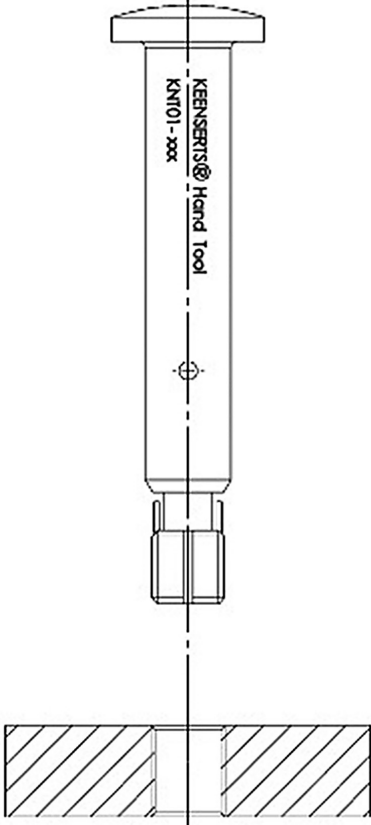
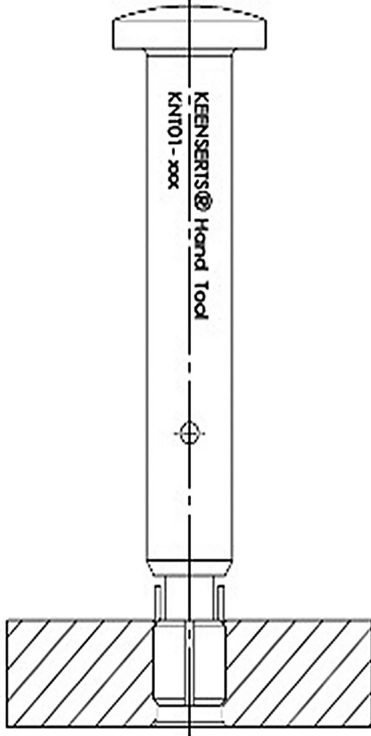
Step 1	Step 2	Step 3
<p>Screw in the KEENSERTS® onto the threaded pin up to the end of the thread.</p> 	<p>Screw the KEENSERTS® into the workpiece until the keys stop on the chamfer or the favored depth is reached (recommended hole preparation).</p> 	<p>Drive in the keys with short and precise hammer taps. Keys can be controlled after each tap until the favored depth is reached or until the anvil stops on the chamfer (final position).</p> 

Available Tool sizes

KEENSERTS® Size	Part Number
KNT01	
KNHM(L)4X0.7	KNT01-HM4x0.7AU
KNM(L)5X0.8	KNT01-M5x0.8AU
KNHM(L)5X0.8	KNT01-HM5x0.8AU
KNM(L)6X1.0	KNT01-M6x1.0AU
KNHM(L)6X1.0	KNT01-HM6x1.0AU
KNM(L)8X1.25	KNT01-M8x1.25AU
KNHM(L)8X1.25	KNT01-HM8x1.25AU
KNM(L)10X1.5	KNT01-M10x1.5AU
KNHM(L)10X1.5	KNT01-HM10x1.5AU
KNM(L)12X1.75	KNT01-M12x1.75AU
KNHM(L)12X1.75	KNT01-HM12x1.75AU

KNT03	
KNHM(L)14x2.0	KNT03-HM14x2.0AU
KNHM(L)16x2.0	KNT03-HM16x2.0AU
KNHM(L)18x1.5	KNT03-HM18x1.5AU
KNHM(L)20x2.5	KNT03-HM20x2.5AU
KNHM(L)24x3.0	KNT03-HM24x3.0AU





KEENSERTS® EPT1 POWER TOOL
BATTERY DRIVEN POWER TOOL FOR CAMLOC® KEENSERTS® INSERTS

Features

- The battery driven Power Tool EPT1 installs metric KEENSERTS® from size M5 to M12 and imperial sizes from 10-32 (10-24) to ½-20 (½-13).
- Portable tool to make installation easy in any environment.
- It is easy to operate due to the one-trigger operation.
- The installation is quick, consistent and reliable.
- The battery powered system is low maintenance, ergonomic and lightweight.
- Individual adjustments can be made using the integrated force control directly via the tool's display.
- Individual language selection via the tool's display.
- Please note: The package includes the Power Tool EPT1, two rechargeable batteries, a charger, a tool wrench and the installation manual.
- An appropriate nosepiece for each size of KEENSERTS® must be ordered separately.
- All nosepieces are compatible with the hydropneumatic KEENSERTS® Power Tool 3352PT1 and 3352PT2.
- For more information please contact Camloc.

Installation video:



Technical Data

Tool	EPT1
Setting Force (Min - Max)	3.0 - 22.0 kN
Max. Spindle Stroke	7.0 mm / 0.276 inch
Tool Weight (without nosepiece)	2.1 Kg / 4.63 Pounds
Battery Weight	0.3 Kg / 0.66 Pounds
Battery	Li-Ion / 14.4 V / 2.6 Ah
Vibrations	< 0.672 m/s ² / < 2.1 ft/s ²
Sound Pressure Level LpA	71.7 dB (A)
Sound Power Level LwA	82.1 dB (A)
Temperature range	5°C - 40°C

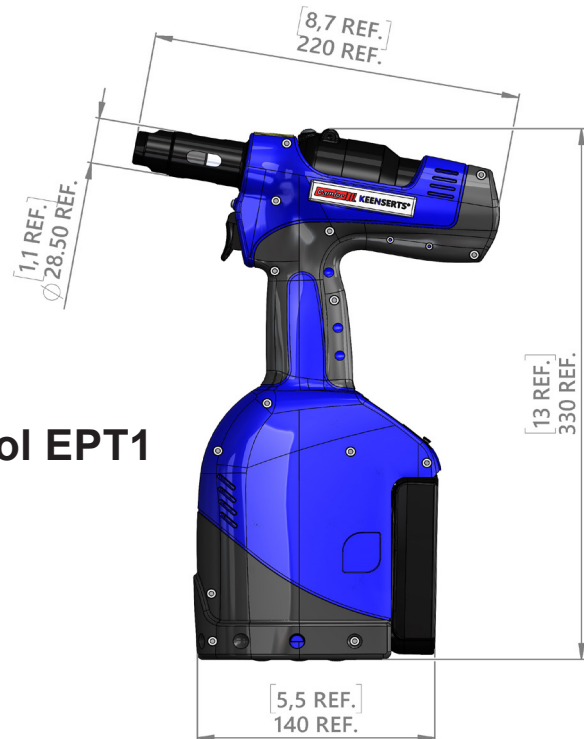

Scope of delivery of the Power Tool EPT1

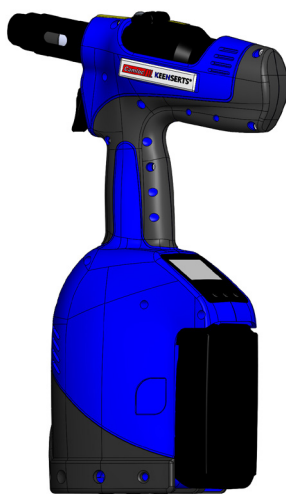

Tool



Tool Wrench

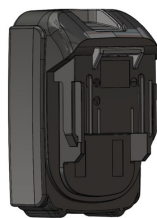

Two Batteries

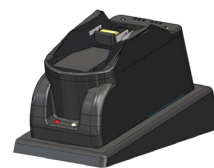

Charging Station

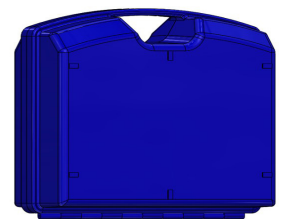

Tool Case

Nosepiece

The KEENSERTS® battery driven Power Tool EPT1 is delivered without nosepieces. The appropriate nosepiece must be ordered separately according to the users needs.

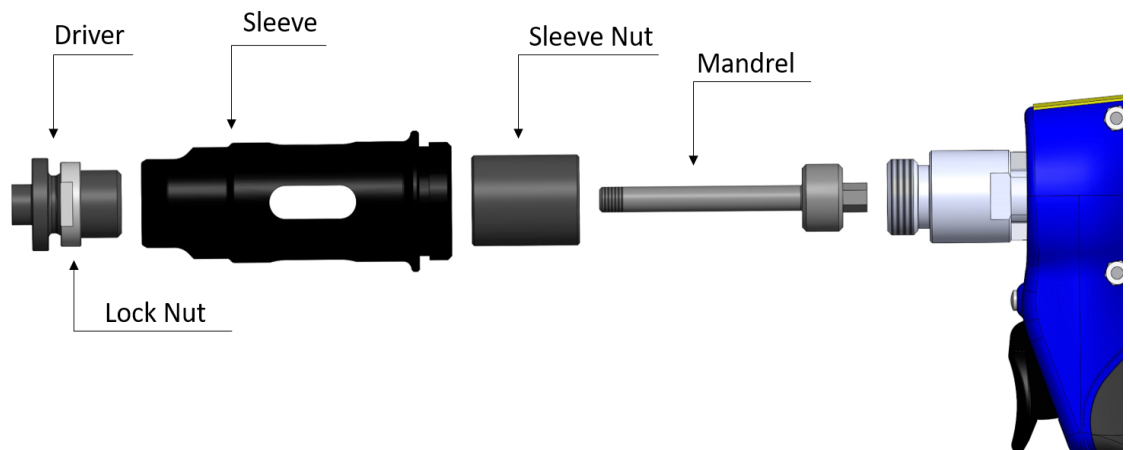

Mandrel, Driver and Lock Nut are components of the nosepiece set for KEENSERTS® installation.







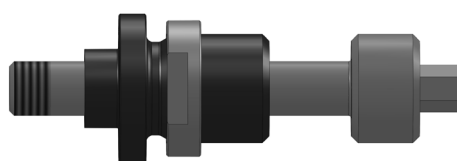

Each component of the nosepiece is available as an individual spare part. In addition to a simplified spare parts order, you can reduce your inventory by using multiple components.

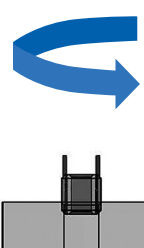
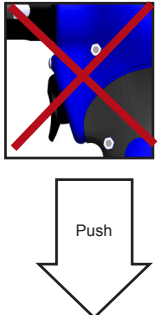
For example, for KEENSERTS® of type KNM6, as well as KNHM6, the same mandrel and lock nut can be used. Only a different driver is required.

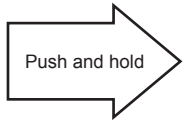
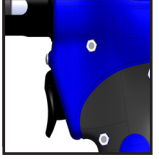
The same nosepiece can also be used for the self-locking version (locking type).



Installation procedure

Step 1	Step 2	Step 3	Step 4	Step 5
<p>Screw in the KEENSERTS® by hand for one to two turns.</p>	<p>Push the outer thread of the mandrel into the inner thread of the KEENSERTS®. The screw-in process will start automatically. Do not press the trigger yet!</p>	<p>The screw-in operation stops automatically once the insert reaches its final position (when the thicker part of the Kees touches the countersunk surface).</p>	<p>Press the trigger for the Kees to be installed.</p>	<p>Keep the trigger pressed. After the Kees are pressed in, the mandrel will rotate counter-clockwise until it has fully unscrewed from the KEENSERTS®. Finally, release the trigger.</p>
				
				

Available metric nosepieces



Part number				
KEENSERTS® size	Nosepiece Set	Spare part mandrel	Spare part driver	Spare part lock nut

KNM Series

KNM(L)5x0.8	3352TM5x0.8AY	3352S04M5x0.8BY	3352S05M5AY	3352S03-1AY
KNM(L)6x1.0	3352TM6x1.0AY	3352S04M6x1.0BY	3352S05M6AY	
KNM(L)8x1.25	3352TM8x1.25AY	3352S04M8x1.25BY	3352S05M8AY	
KNM(L)10x1.5	3352TM10x1.5AY	3352S04M10x1.5BY	3352S05M10AY	
KNM(L)12x1.75	3352TM12x1.75AY	3352S04M12x1.75BY	3352S05M12AY	

KNHM Series

KNHM(L)5x0.8	3352THM5x0.8AY	3352S04M5x0.8BY	3352S05HM5AY	3352S03-1AY
KNHM(L)6x1.0	3352THM6x1.0AY	3352S04M6x1.0BY	3352S05HM6AY	
KNHM(L)8x1.25	3352THM8x1.25AY	3352S04M8x1.25BY	3352S05HM8AY	
KNHM(L)10x1.5	3352THM10x1.5AY	3352S04M10x1.5BY	3352S05HM10AY	
KNHM(L)12x1.75	3352THM12x1.75AY	3352S04M12x1.75BY	3352S05HM12AY	

Available imperial nosepieces

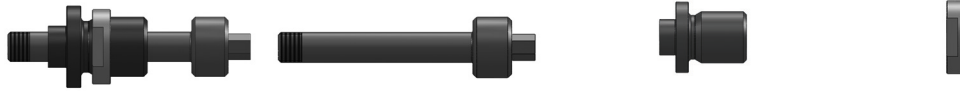

Part number				
KEENSERTS® Size	Nosepiece Set	Spare part mandrel	Spare part driver	spare part lock nut

KNJ Series

KN(L)1032J	3352T1032AY	3352S01-1032BY	3352S02-10AY	3352S03-1AY
KN(L)1024J	3352T1024AY	3352S01-1024BY		
KN(L)428J	3352T428AY	3352S01-428BY	3352S02-1/4AY	
KN(L)420J	3352T420AY	3352S01-420BY		
KN(L)524J	3352T524AY	3352S01-524BY	3352S02-5/16AY	
KN(L)518J	3352T518AY	3352S01-518BY		
KN(L)624J	3352T624AY	3352S01-624BY	3352S02-3/8AY	
KN(L)616J	3352T616AY	3352S01-616BY		
KN(L)720J	3352T720AY	3352S01-720BY	3352S02-7/16AY	
KN(L)714J	3352T714AY	3352S01-714BY		
KN(L)820J	3352T820AY	3352S01-820BY	3352S02-1/2AY	
KN(L)813J	3352T813AY	3352S01-813BY		

KNHJ Series

KNH(L)1032J	3352TH1032AY	3352S01-1032BY	3352S02-H10AY	3352S03-1AY
KNH(L)1024J	3352TH1024AY	3352S01-1024BY		
KNH(L)428J	3352TH428AY	3352S01-428BY	3352S02-H1/4AY	
KNH(L)420J	3352TH420AY	3352S01-420BY		
KNH(L)524J	3352TH524AY	3352S01-524BY	3352S02-H5/16AY	
KNH(L)518J	3352TH518AY	3352S01-518BY		
KNH(L)624J	3352TH624AY	3352S01-624BY	3352S02-H3/8AY	
KNH(L)616J	3352TH616AY	3352S01-616BY		
KNH(L)720J	3352TH720AY	3352S01-720BY	3352S02-H7/16AY	
KNH(L)714J	3352TH714AY	3352S01-714BY		
KNH(L)820J	3352TH820AY	3352S01-820BY	3352S02-H1/2AY	
KNH(L)813J	3352TH813AY	3352S01-813BY		